

VITOCROSSAL 300®

High efficiency gas-fired condensing boiler
Rated input: 638 to 3361 MBH
187 to 985 kW

VIESSMANN®

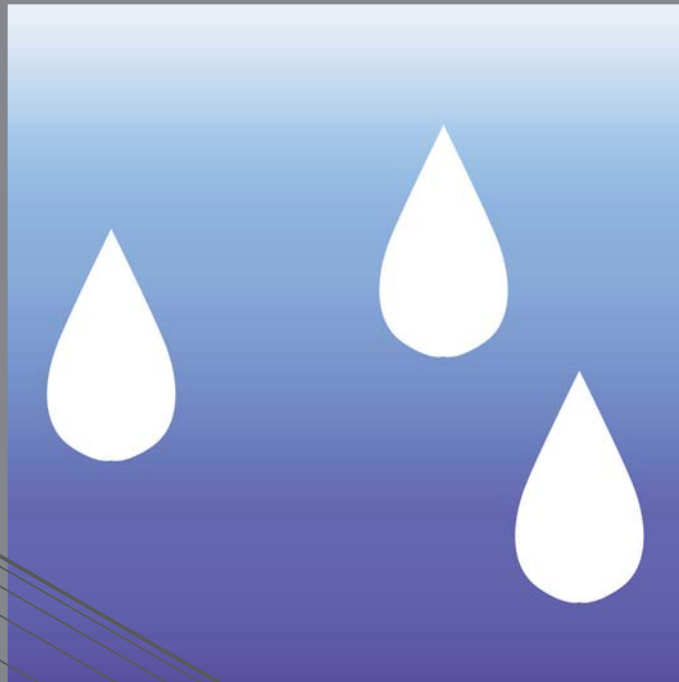



Vitocrossal 300
187 to 985 kW
638 to 3361 MBH

State-of-the-Art Condensing Technology

Condensing technology - the most advanced way to heat

Condensing technology maximizes fuel utilization and reduces your heating bills. By capturing the portion of latent heat, which in conventional heating boilers is lost through the chimney, condensing boilers, like the Vitocrossal 300, use as much as 98% of the original energy input to heat your building.

Environmentally-friendly

Apart from economic considerations condensing technology also minimizes the environmental impact of the heating system. Better fuel utilization means lower fuel consumption and consequently lower emissions.

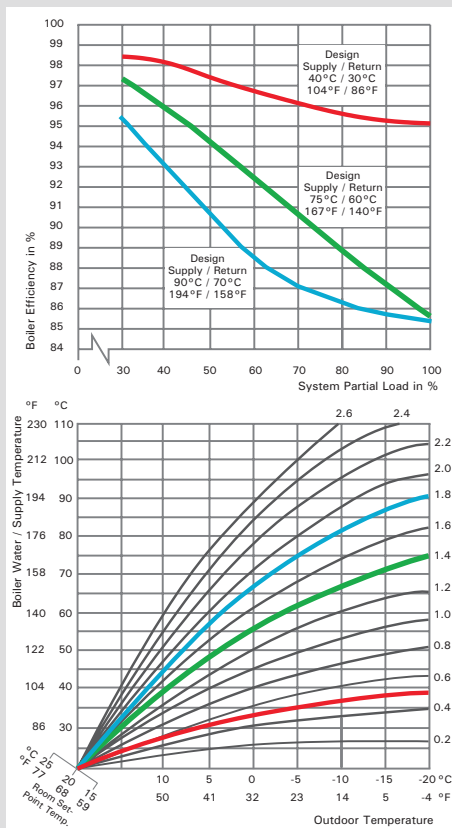

Vitocrossal 300 boiler efficiency is dependent on heating water return temperatures and load conditions

Due to their high efficiency and low energy consumption, condensing boilers, like the Vitocrossal 300, can contribute to green building certification, such as the Leadership in Energy and Environmental Design (LEED) program.

The right choice for new construction or renovation

Condensing boilers can be used in a variety of temperature applications in both new construction or retrofits.

A condensing boiler, however, provides the most benefit in applications with low operating temperatures, such as radiant floor heating, snowmelting systems, oversized radiators and fan coils. The low boiler supply and return temperatures of these systems facilitate the condensing of the flue gases and extraction of additional, latent heat, resulting in peak efficiencies and maximum energy savings.

In systems with medium to high operating temperatures, condensing boilers combined with outdoor reset control technology, are still able to achieve high efficiencies, especially in the shoulder season. The combination of a condensing and non-condensing boiler is often used in multi-temperature systems to satisfy the various temperature requirements most effectively.

Today, the use of condensing technology is almost a given, especially in new construction when the temperature requirements of the system and can be matched perfectly with the boiler.



The cornerstone of Viessmann condensing technology - high-grade stainless steel

Reliable and economical

In order to maximize the benefits of condensing technology, look for the following features in your condensing boiler:

- The use of reliable and corrosion-resistant materials such as stainless steel
- Highly effective heat exchanger surfaces for low flue gas temperatures and high condensation rates
- Matching, innovative burner technology
- Low after-sales costs, e.g. for system monitoring, maintenance and repair
- Total system solutions, which only a large manufacturer with extensive experience, and a wide complementary product range, such as Viessmann, can offer

Viessmann Condensing Technology

Viessmann offers a complete line of gas-fired floor-standing and wall-mounted condensing boilers from 9 to 985 kW / 25 to 3361 MBH.

For commercial applications, the floor-standing Vitocrossal 300 condensing boiler, with the new generation of Vitotronic control units, offers complete and matching system technology for exploiting condensing technology up to 985 kW / 3361 MBH.

The Vitocrossal 300 at a Glance

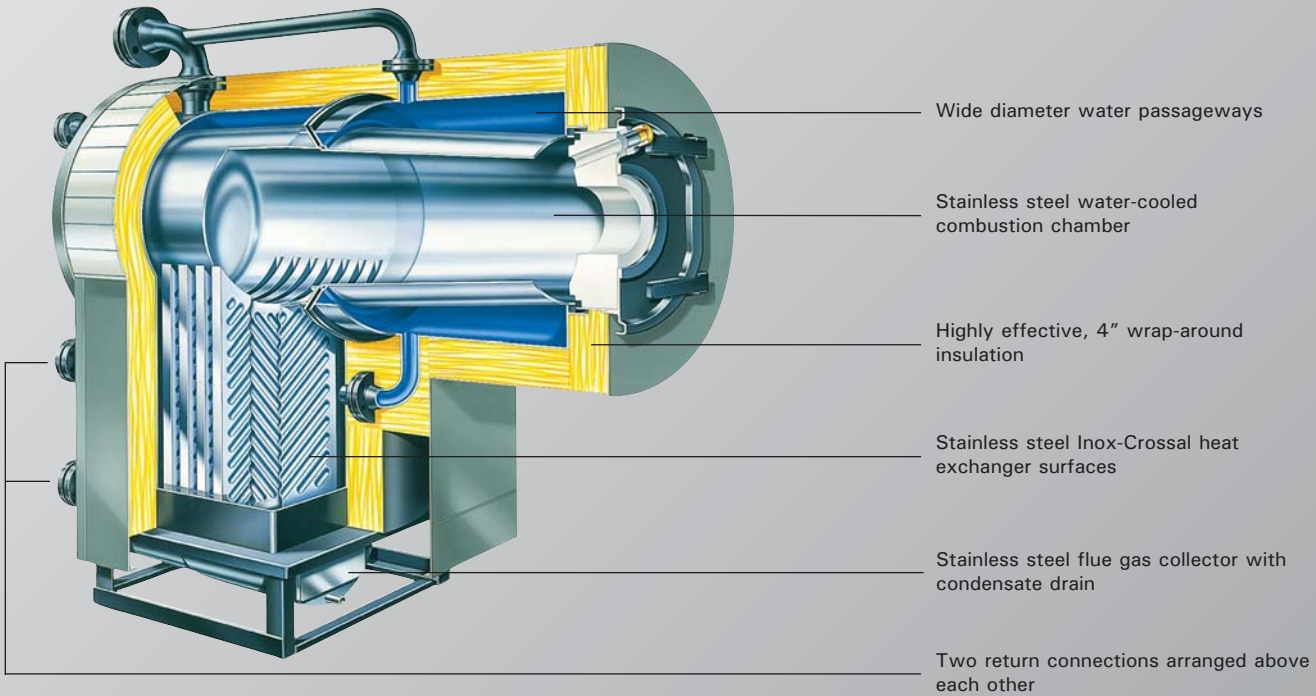

| VITOCROSSAL 300 | | | Model No. | CT3- | 17 | 22 | 28 | 37 | 46 | 57 | 72 | 89 |
|-----------------------|---------|--------|-----------|------|------|------|------|------|------|------|------|------|
| Input | MBH | kW | | | 638 | 846 | 1071 | 1389 | 1726 | 2160 | 2702 | 3361 |
| | | | | | 187 | 248 | 314 | 407 | 506 | 633 | 792 | 985 |
| Output* | MBH | kW | | | 626 | 827 | 1044 | 1350 | 1675 | 2094 | 2616 | 3252 |
| | | | | | 183 | 242 | 306 | 396 | 491 | 614 | 767 | 953 |
| Combustion efficiency | MBH | | | | 98.3 | 97.8 | 97.4 | 97.2 | 97.1 | 96.9 | 96.8 | 96.7 |
| Thermal efficiency | MBH | | | | 98.1 | 97.7 | 97.4 | 97.2 | 97.1 | 96.9 | 96.8 | 96.7 |
| Overall dimensions | Length | inches | | | 64½ | 67½ | 70½ | 73½ | 76¾ | 83 | 85½ | 93¼ |
| | | mm | | | 1636 | 1714 | 1795 | 1871 | 1949 | 2105 | 2172 | 2366 |
| | Width** | inches | | | 43 | 43 | 43 | 47¾ | 47¾ | 47¾ | 52¼ | 52¼ |
| | | mm | | | 1095 | 1095 | 1095 | 1211 | 1211 | 1211 | 1328 | 1328 |
| | Height | inches | | | 77 | 79 | 80 | 90 | 90 | 90 | 100 | 100 |
| | | mm | | | 1959 | 2009 | 2032 | 2290 | 2290 | 2290 | 2537 | 2537 |
| Weight** | lbs | kg | | | 1228 | 1352 | 1455 | 1962 | 2064 | 2322 | 3014 | 3344 |
| | | | | | 557 | 613 | 660 | 890 | 936 | 1053 | 1370 | 1520 |

* Output ratings are based on the IBR BTS-2000 "method to determine efficiency of commercial space heating boilers".

** Includes insulation and control.

Innovative Technology, Proven Performance

The Vitocrossal 300 is an exceptionally efficient and environmentally-friendly gas-fired condensing boiler for semi-commercial or commercial heating applications - from large custom homes to apartment buildings, schools and other public and commercial spaces. Superior efficiency, highest-quality materials and proven Viessmann condensing technology translate into increased savings in fuel and maintenance costs.

Built to last

The Vitocrossal 300 is constructed using only the highest quality materials. The Inox-Crossal vertical heat exchanger surface is made of high-grade SA 240-316 Ti stainless steel - ideal for condensing applications.

Corrosive condensate simply drains downward off the smooth surfaces, effectively self-cleaning the heat exchanger and extending the operational life of the boiler, while reducing maintenance costs.

Benefits at a glance

- **High operational reliability and long service life** with the vertical Inox-Crossal heat exchanger surfaces.
 - Easy dispersal of condensate through vertical passageways; therefore no concentration of condensate.
 - Increased self-cleaning effect through smooth stainless steel surfaces.
- **Highly efficient heat transfer and high condensation rate** is achieved with:
 - highly turbulent flow of flue gas through the heat exchanger.
 - Boiler water and hot gases flowing in counterflow.
 - Large heat exchanger surface area to energy input ratio.
- **Efficiency up to 98.3%** through intensive flue gas condensation. The flue gas temperature is only approx. 9 - 27°F / 5 - 15°C above boiler return temperature.
- **Clean combustion** - through perfect match of burner and boiler and low combustion chamber thermal loading.
- **Two return connections** - providing separate connection for heating circuits with lower return temperature, allowing for increased condensation.
- **Easy handling in boiler rooms** through particularly low build height and weight; larger sizes from 638 MBH / 187 kW are available in two sections.
- **Easy installation and elimination of wiring mistakes** with Viessmann prewired plug-in system.
- Heating boiler, heating system control, domestic hot water storage tank and all other **Viessmann system technology** components are co-ordinated to work perfectly with one another. All **components are design-matched** for quick installation.
- **Economical and reliable heating system operation** through Vitotronic digital control system with communication capability. Tailored to every need, covering all known control strategies and applications.
- Standard LON BUS for **complete integration into building management systems**. Easy integration into the Vitocontrol control panel.
- Vitocrossal boilers meet the stringent standards required to carry the **Environmental Choice** logo.



Inox-Crossal heat exchanger surface constructed of stainless steel for high operational reliability and long service life



Single-boiler systems

VITOTRONIC 100, GC1



Digital boiler setpoint control designed for external demands from BMS and DDC systems using a 0-10 VDC or LON signal or for maintaining constant boiler water temperature without demands. Provides easy single cable connection to the Vitocontrol-S for multiple boiler application. Domestic hot water heating is a standard feature with this control.

VITOTRONIC 300, GW2



Digital outdoor reset boiler control for modulating burner, boiler water temperature and up to two heating circuits with mixing valves. Domestic hot water heating is a standard feature with this control.

Multi-boiler systems

VITOCONTROL-S, CT3



Digital outdoor reset cascade control for up to four heating boilers. Designed to operate with or without setpoint demands from BMS or DDC systems. The Vitocontrol-S will modulate burners, stage and rotate boilers, regulate boiler water temperature, common supply temperature and up to two heating circuits with mixing valves. Domestic hot water heating is a standard feature with this control.

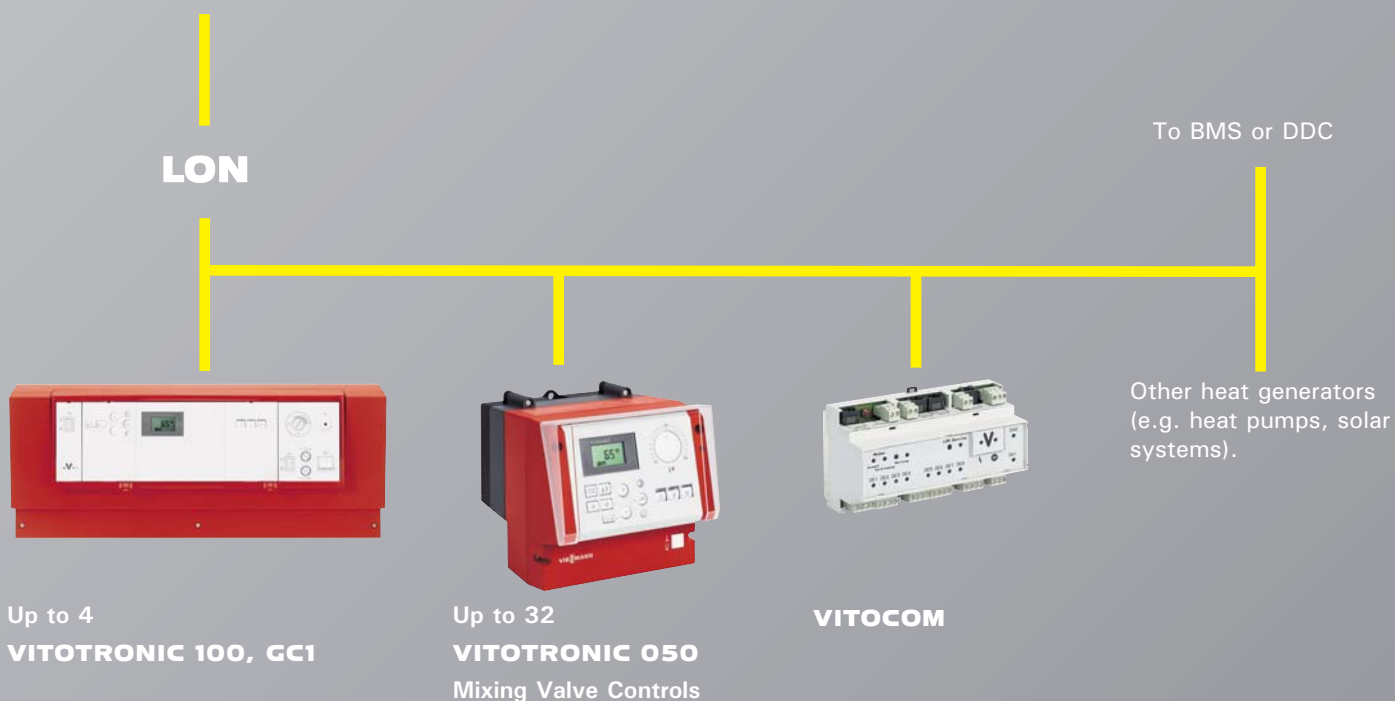

Intelligent Energy Management

The Vitotronic digital control system ensures the economical and reliable operation of the entire heating system.

The modular technology based on the Viessmann platform strategy enables essential components and functions of the Vitotronic control units for residential systems to also be used for medium and large heating systems.

Common features include unified operation and simple installation, start-up and maintenance with the Rast-5 plug-in system and plug-and-work functionality.



Fast and simple installation with the Rast-5 plug-in system

The standardized LON bus enables a simple and complete integration into building management systems (BMS). The Vitocom 300 communication interface also allows for remote control/remote monitoring of the heating system.

Vitotronic 100

The Vitotronic 100, GC1 digital setpoint boiler control is designed for operation with higher boiler water temperatures in single-boiler systems or for the first to fourth boiler in multi-boiler systems (in conjunction with the Vitocontrol-S, CT3 cascade control).

Vitotronic 300

The Vitotronic 300, GW2 digital boiler control is designed for single-boiler systems with modulating boiler water temperatures. It also provides control for two further heating circuits with a mixing valve. In case of multiple heating circuits with mixing valves, a maximum of 32 Vitotronic 050 mixing valve control units can be connected using the LON bus.

Vitocontrol-S, CT3

The Vitocontrol-S, CT3 is a digital cascade control for operating up to four boilers in conjunction with Vitotronic 100, GC1 controls and up to two heating circuits with mixing valve.

This control also supports direct connection to the LON bus for control of up to 32 Vitotronic 050 mixing valve control units.

It provides all known control strategies for multi-boiler systems and allows easy integration into Building Management Systems (BMS) without an additional interface.

Additional heat generators can also be integrated.

Custom control panels

Custom control panels for residential or commercial applications are designed and manufactured by Viessmann to suit any customer's specific requirements. Custom control panels can have features such as pool heating, hot tub heating, snow melting, telephone tie-in, integration with Building Management Systems (BMS), and more.



Viessmann Vitocontrol custom control panel



Vitocell DHW tanks
160 - 450 liters
42 - 120 USG

Clean, Reliable Hot Water - All the Time

Apartment buildings and commercial facilities need to be able to rely on a dependable and economical supply of domestic hot water.

Vitocell 300 indirect-fired DHW storage tanks combine comfort, convenience and reliability in one package. Available in vertical and horizontal designs from 160 - 450 liters / 42 - 120 USG, they are able to meet every demand.

Durable construction, fast recovery rates, large water volume, and low standby losses ensure an abundant supply of hot water and even water temperatures at all times.

Long service life

Both tank and heat exchanger of the Vitocell 300 DHW tanks are made of SA 240-316 Ti stainless steel, a material known for its durability, hygiene, acid resistance and esthetic appearance. Minimal wear, even after years of service, combined with the fact that no additional corrosion protection is required, translate into maximum cost savings.



Vitocell-B 300 dual-coil solar tank



Vitocell 300 DHW tank made of stainless steel

Efficiency

Extremely efficient domestic hot water production using the heating water from the boiler to heat the tank water.

Save up to 50% in operating cost compared to most conventional (direct-fired) domestic hot water tanks.

Highly-effective HCFC-free foamed-in-place or wrap-around insulation reduces standby losses and operating cost to a minimum.

Solar option

The Vitocell-B 300 indirect-fired dual-coil DHW tank allows for the integration of a solar system to augment the production of domestic hot water.

Available in vertical design from 300 - 450 liters / 79 - 120 USG storage capacity, this tank offers all the features of a Vitocell 300 stainless steel tank - and more.

Benefits at a glance

- **High level of operational reliability and a long service life** due to high-grade stainless steel construction.
- **Convenience** - Fast recovery rates ensure **abundant supply of domestic hot water** all day long.
- **Comfort** - Tank coil extends all the way to the bottom guaranteeing even water temperatures at all times.
- **Scale and corrosion-resistant**, ideal for areas with poor water quality. **Completely hygienic!**
- Highly-effective wrap-around insulation keeps **standby losses and operating costs to a minimum.**
- **High-volume hot water** - several Vitocell 300 tanks can be combined into tank batteries.
- **Space-saving options:** Vitocell-H 300 tanks may be stacked on top of each other. **Zero clearance to combustibles** for all Vitocell 300 tanks.
- Approved by the State of Massachusetts as **ASME Equivalent.**
- All Vitocell 300 DHW tanks meet the stringent standards required to carry the **Environmental Choice** logo.





Progressive Heating Technology is System Technology

Every component of our heating technology follows the Viessmann building block principle. This guarantees a smooth and efficient functioning of the entire heating system. All boilers, burners and controls harmonize perfectly, while saving you energy and money.

System components

- Viessmann-designed system controls are design-matched to work with other system componentry to ensure efficient and reliable operation of the entire heating system.
- Weishaupt and Riello low-NOx modulating gas-fired burners are designed for quick installation and offer reliable combustion. Weishaupt burners are supplied with pre-wired gas trains.
- Viessmann Vitocell steel enamel-lined or stainless steel domestic hot water tanks ensure worry-free, highly efficient, reliable DHW production.
- Boiler safety header, complete with 30 psig pressure relief valve, air vent, pressure gage, boiler drain valve and insulation shell.
- Custom stainless steel chimney system for effective and reliable venting of the heating system.
- Viessmann custom control panels manage the operation of multiple boilers, heating circuits and DHW production. Our custom design ensures a perfect fit with system components to maximize efficiency and cost savings.

Integrating a solar system

Viessmann offers a complete line of high-quality flat plate and vacuum tube solar collectors and system components designed to integrate seamlessly with Viessmann boiler technology and DHW heating systems.

Integrating a solar system into your mechanical design can significantly offset the heating cost of your building and reduce your environmental footprint. Our high-performance solar collectors are ideal for heating your domestic hot water - the hot water you use to take showers, do laundry, etc. In some cases, a solar system can be used, together with a low-temperature hot water heating system, to support your space heating load or for pool heating.

Commercial Project Evaluation Program (CPEP)

This powerful evaluation tool enables system builders, design consultants, engineers and heating specialists to analyze the expected performance of a proposed commercial Viessmann heating system. Calculate fuel savings, emission reduction and life cycle cost (LCC) before you install.

Service, education and support starts with Viessmann

- A commercial projects department offering technical advice.
- Ongoing post-sale customer support.
- Custom control solutions and full integration with building management systems (BMS).
- Remote system monitoring over the internet.
- Free commercial project evaluation program to calculate fuel savings, R.O.I., pay-back, LCC analysis, and emission reductions.
- Professional start-ups for all commercial installations.
- Educational seminars through our Viessmann Academy.



Professional advice is never far away



Hands-on training at our demonstration showrooms



Keeping up-to-date is easy with Viessmann Academy seminars



Viessmann

With more than 8,000 employees around the world, the Viessmann Group is one of the leading manufacturers of heating technology worldwide. Viessmann represents competence and innovation and offers you a wide variety of high-tech heating products, each a design-matched component in the progressive Viessmann system technology. Despite their diversity, Viessmann products have one thing in common: a high standard of quality throughout the entire product line that translates into operational reliability, energy savings, environmental friendliness and operational comfort.

Viessmann innovations lead the industry not only in conventional heating technology, but also in the area of renewable energy sources such as solar and heat pump technology.

All of our products are developed in accordance with our philosophy to achieve the greatest value at all times – for our customers and our business partners.

Contact the Viessmann office in Canada or U.S.A. for the name of the Viessmann Sales Representative closest to you.

North American and Canadian Head Office
 Viessmann Manufacturing Company Inc.
 Waterloo, ON Canada
 Tel. 1-800-387-7373
 Fax (519) 885-0887
 www.viessmann.ca

U.S. Head Office
 Viessmann Manufacturing Company (U.S.) Inc.
 Warwick, RI U.S.A.
 Tel. 1-800-288-0667
 Fax (401) 732-0590
 www.viessmann-us.com

Viessmann Sales Center
 Langley, BC Canada 1-877-853-3288

Viessmann Sales Offices
 Waterloo, ON Canada (226) 338-7038
 Toronto, ON Canada (416) 657-4333
 Stony Creek, ON Canada (905) 664-4426
 Reno, NV U.S.A. (775) 849-0725



Viessmann meets all your heating needs with a diverse, yet completely harmonized product range.

