

Service and Maintenance Instructions

for use by engineers and heating contractors

VIESSMANN

Vitoflex 300-RF 150, 220, 300, 400 and 540

Wood-fired Boiler

Output range: RF 150 154 to 512 MBH (45 to 150 kW)

RF 220 205 to 751 MBH (60 to 220 kW)

RF 300 273 to 1024 MBH (80 to 300 kW)

RF 400 341 to 1365 MBH (100 to 400 kW)

RF 540 478 to 1843 MBH (140 to 540 kW)



Vitoflex 300-RF



WARNING

If the information in this manual is not followed exactly, a fire or explosion may result causing property damage, personal injury or loss of life.

Do not store or use gasoline or other flammable fluids in the vicinity of this or any other appliance.

WHAT TO DO IF YOU SMELL FLUE GAS

- Deactivate heating equipment
- Open windows and doors.
- Inform your heating contractor

WARNING

Improper installation, adjustment and/or operation could cause carbon monoxide poisoning resulting in injury or loss of life. This product must be installed and serviced by a professional service technician who is experienced and qualified in hot water boiler installation and wood fuel combustion.



Product may not be exactly as shown

IMPORTANT

Read and save these instructions for future reference.

Safety, Installation and Warranty Requirements

Please ensure that these instructions are read and understood before commencing service and/or maintenance. Failure to comply with the instructions listed below and details printed in this manual can cause product/property damage, severe personal injury, and/or loss of life. Ensure all requirements below are understood and fulfilled (including detailed information found in manual subsections).

■ Product documentation

Read all applicable documentation before commencing installation. Store documentation near boiler in a readily accessible location for reference in the future by service personnel.

►For a listing of applicable literature, please see section entitled "Important Regulatory and Safety Requirements".



■ Warranty

Information contained in this and related product documentation must be read and followed. Failure to do so renders the warranty null and void.



■ Licensed professional heating contractor

The installation, adjustment, service and maintenance of this equipment must be performed by a licensed professional heating contractor.

►Please see section entitled "Important Regulatory and Installation Requirements".



■ Contaminated air

Air contaminated by chemicals can cause by-products in the combustion process, which are poisonous to inhabitants and destructive to Viessmann equipment.

►For a listing of chemicals which cannot be stored in or near the boiler room, please see subsection entitled "Mechanical Room".



■ Advice to owner

Once the installation work is complete, the heating contractor must familiarize the system operator/ultimate owner with all equipment, as well as safety precautions/requirements, shutdown procedure, and the need for professional service.

■ Carbon monoxide

Improper installation, adjustment, service and/or maintenance can cause flue products to flow into living space. Flue products contain poisonous carbon monoxide gas.

►For information pertaining to the proper installation, adjustment, service and maintenance of this equipment to avoid formation of carbon monoxide, refer to the installation and operating instructions.



■ Fresh air

This equipment requires fresh air for safe operation and must be installed ensuring provisions for adequate combustion and ventilation air exist.

►For information pertaining to the fresh air requirements of this product, please see subsection entitled "Combustion Air Supply".

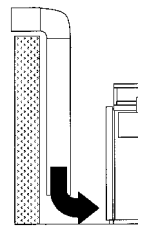

■ Equipment venting

Never operate the boiler without an installed venting system. An improper venting system can cause carbon monoxide poisoning.

►For information pertaining to venting and chimney requirements, refer to the installation and operating instructions. All products of combustion must be safely vented to the outdoors.



! WARNING

Installers must follow local regulations with respect to installation of carbon monoxide detectors. Follow manufacturer's maintenance schedule of the boiler contained in the section "Cleaning and Maintenance".

About these Instructions

 Take note of all symbols and notations intended to draw attention to potential hazards or important product information. These include "WARNING", "CAUTION", and "IMPORTANT". See below.

 WARNING
Warnings draw your attention to the presence of potential hazards or important product information.

► *Indicates an imminently hazardous situation which, if not avoided, could result in death, serious injury or substantial product/property damage.*

 CAUTION
Cautions draw your attention to the presence of potential hazards or important product information.

► *Indicates an imminently hazardous situation which, if not avoided, may result in minor injury or product / property damage.*

IMPORTANT

► *Helpful hints for installation, operation or maintenance which pertain to the product.*



► *This symbol indicates to note additional information*



► *This symbol indicates that other instructions must be referenced.*

Note: Viessmann Manufacturing Company Inc. reserves the right to make product changes or updates without notice and will not be held liable for errors or omissions in the product literature.

	Page
Introduction	
	Safety, Installation and Warranty Requirements.....2
	About these Instructions.....3
General Information	
	Product Information.....5
	Important Regulatory and Installation Requirements6
Safety	
	Safety Instructions.....8
	Carbon Monoxide.....9
	Extreme Weather Conditions.....10
	Hazardous Material.....11
	Mechanical Room.....12
	Combustion Air Supply.....13
Maintenance	
	Components of the Biomass Boiler.....14
	Cleaning.....15
	Boiler.....15
	Heat exchanger displacement rods.....16
	Pneumatic cleaning system (optional).....17
	Shutdown.....17
	Boiler.....17
	Extraction and conveyance systems.....17
	Control system.....17
	Ash disposal.....17
Troubleshooting	
	Warning Message 18
	Fault Message 18
	Adjusting the Fuel Supply and Air Supply 24
	Adjusting the Ash Removal.....24
	Visual Inspection of Combustion25
	Unjamming the Ash Removal Screw Conveyor25
	Fault Messages 26
Maintenance	
	Information on Maintenance27
	Responsible Groups 27
	Annual General Inspection27
	Servicing the Boiler.....28
	Cleaning the Boiler29
	Servicing the Flue Gas Dust Extrator (optional).....32
	Servicing the Conveyor Devices33

Product Information

Viessmann solid-fuel boiler can only be installed and serviced by qualified trained personnel.

Steel wood-fired hot water heating boiler.

For operation primarily with modulating boiler water temperatures in closed loop forced circulation hot water heating systems. Under certain conditions, open loop systems may also be considered. Contact Viessmann for details.

Maximum allowable working pressure (water).... 30 or 60 psi

Maximum water temperature 250°F (120°C) (closed loop)

Maximum boiler temperature 210°F (99°C) (open loop)

This boiler does not require a flow switch.

WARNING

Exposing the boiler to pressures and temperatures in excess of those listed will result in damages and will render the warranty null and void.

Codes and standards

CSA B366.1-M91

Solid Fuel Fired Central Heating Appliances

CSA C22.2 No. 3 - M1988 (latest edition)

Electrical Features of Fuel Burning Equipment

UL2523

Solid Fuel-Fired Hydronic Heating Appliances, Water Heaters and Boilers

CSA B365 (latest edition)

Installation Code for Solid Fuel Burning Appliances and Equipment

ASME section IV boilers and pressure vessels

Important Regulatory and Installation Requirements

Please carefully read this manual prior to attempting service and maintenance. Any warranty is null and void if these instructions are not followed.

For information regarding other Viessmann System Technology componentry, please reference documentation of the respective product.

We offer frequent installation and service seminars to familiarize our partners with our products. Please inquire.

Working on the equipment

The installation, adjustment, service, and maintenance of this boiler must be done by a licensed professional heating contractor who is qualified and experienced in the installation, service, and maintenance of hot water boilers.

Ensure main power supply to equipment, the heating system, and all external controls have been deactivated. Take precautions to avoid accidental activation of power during service work.

- ▶ *The completeness and functionality of field supplied electrical controls and components must be verified by the heating contractor. These include low-water cut-offs, flow switches (if used), staging controls, pumps, motorized valves, air vents, thermostats, etc.*



CAUTION

RISK OF INJURY: Shut the system off before starting any cleaning. Be absolutely sure to wear protective gloves, protective eyewear if required and use the cleaning tools that come with the system (danger of blow-ups, burns and getting crushed)!

Technical literature

Literature applicable to all aspects of the Vitoflex 300-RF wood-fired boiler:

- Installation and Operating Instructions
- Service and Maintenance Instructions
- Field Wiring Diagram

- ▶ *Leave all literature at the installation site and advise the system operator/ultimate owner where the literature can be found. Contact Viessmann for additional copies.*
- ▶ *This product comes with several safety instruction labels attached. Do not remove! Contact Viessmann immediately if replacement labels are required.*

Important Regulatory and Installation Requirements *(continued)*

Regular maintenance and service

The entire heating system must be cleaned and serviced on a regular basis by a qualified contractor or service agency to ensure reliable, energy-efficient, and environmentally friendly operation.

The build-up of soot on the heat exchanger raises the flue gas temperature and reduces efficiency.

! WARNING

The boiler must not be located in areas or rooms where chemicals are stored or aggressive vapors from (e.g. bleach, hair spray, methyl chloride, carbon tetrachloride or perchloroethylene) or high dust levels or humidity levels are present. Heat exchanger corrosion might occur and reduce the lifetime of the boiler significantly. If above criteria are not properly observed and boiler damage results, any warranty on the complete boiler and related components will be null and void.

IMPORTANT

Keep boiler and boiler room clear and free of combustible materials, gasoline and other flammable vapors and liquids. Do not obstruct the flow of combustion and ventilation air. All inspection, maintenance and service must be performed by a qualified heating contractor.

! WARNING

Improper installation, adjustment, service or maintenance can cause flue products to flow into living space. Flue products contain poisonous carbon monoxide gas, which can cause nausea or asphyxiation resulting in severe personal injury or loss of life.

! WARNING

Service and maintenance can only be performed by a qualified heating contractor.

Important to know

Do not use this boiler if any part has been under, or exposed to, water. Immediately call a qualified heating contractor to inspect the boiler and to replace any part of the control system, which has been under or exposed to water.

Safety Instructions

IMPORTANT

The local building codes and regulations must be followed by the heating contractor.

IMPORTANT



Please refer to the Installation and Operating Instructions for installation, commissioning and technical specification information. The "Installation and Operating Instructions" contain the necessary safety and national/local code requirements which, if not followed exactly, may lead to property damage, personal injuries and/or death.

Important Information

Safety instructions

When carrying out work on the heating system, such as cleaning and maintenance, wear appropriate protective equipment when required.

There is a danger of getting injured through: burning, knocking against corners and edges, crushing in moving parts and noise.

Power supply: 120/1/60 VAC and 240/1/60 VAC.
In case of an emergency, the Vitoflex 300-RF can be disconnected from the electrical power supply at all the leads by the main switch on the control cabinet.

If you notice fire coming from the appliance, call the fire department immediately!
DO NOT attempt to extinguish the fire unless qualified to do so.

WARNING

Fire causes a risk of burns and explosion!

- Shut down the boiler
- Close fuel shut-off valves
- Use a tested fire extinguisher, class ABC.

Doors: for safety keep firing and ash pit doors tightly closed

CAUTION

FIRE HAZARD:

The boiler must **NEVER** be operated with the doors open!
Any burning bits that escape could start a fire.

RISK OF INJURY:

If the doors are open during operation, sparks or flames could leap out.

Equipment for dissipating excess heat: a competent specialist should examine the operational reliability of the thermal safety flush valve annually. The safety heat exchanger must not by any means be used as an operational heat exchanger.

Seals: for the functioning and controllability of the boiler, it is important that no unwanted air can enter unchecked through leaks.

The doors and lids have to shut tight - any damaged seals must be replaced immediately. Tighten the retaining screws and handles well.

Operation, cleaning and maintenance: bear in mind that even the best product can only fulfill its functions well, doing so for a long time and free of malfunctions, if operated and maintained properly.

IMPORTANT

Compliance with the "Cleaning" section is mandatory!

Carbon Monoxide

Carbon monoxide

The U.S. Consumer Product Safety Commission strongly recommends the installation of carbon monoxide detectors in buildings in which wood-burning equipment is installed. Carbon monoxide (CO) is a colorless, odorless gas, which may be produced during incomplete combustion of fuel and/or when the flame does not receive an adequate supply of combustion air. Carbon monoxide can cause severe personal injury or loss of life.

Therefore, carbon monoxide detectors that are in compliance with a nationally recognized standard (e.g. ANSI/UL 2034-2002, CSA 6.19-01) should be installed and maintained in buildings that contain wood-burning equipment.

Note: Viessmann does not test any detectors and makes no representation regarding any brand or type of detector.

For safe operation

We recommend that you frequently:

- Check for debris which could obstruct the flow of flue gases. The vent or chimney must not be blocked. A blocked or partially blocked vent or chimney can cause flue gases to leak into the structure. Flue gases leaking into the house can cause injury or death. Blocked or partially blocked chimneys must have the blockage removed by a qualified heating contractor.
- Check pressure gage for correct system (water) pressure. Check for water on the floor from the discharge pipe of the pressure relief valve or any other pipe, pipe joint, valve or air vent.
- Check for moisture, water, or appearance of rust on the flue gas pipes, their joints as well as vent dampers, or side wall vent terminals (if so equipped).
- Ensure that nothing is obstructing the flow of combustion and ventilation air and no chemicals, garbage, gasoline, combustible materials, flammable vapors and liquids are stored (not even temporarily) in the vicinity of the boiler.
- DO NOT allow unsupervised children near the boiler.

Service/inspection of the boiler and the system must be performed on a regular basis. Maintenance, service and cleaning are specified in the section "Maintenance".

Before the heating season begins, it is recommended that the boiler be serviced by a qualified heating contractor.

WARNING

Improper installation, adjustment, service or maintenance can cause flue products to flow into living space. Flue products contain poisonous carbon monoxide gas, which can cause nausea or asphyxiation resulting in severe personal injury or loss of life.

WARNING

The operator/ultimate owner is required to have the heating boiler and controls checked, as a minimum once per year, by the original installer or by a competent heating contractor familiar with the equipment. Defects must be corrected immediately.

Extreme Weather Conditions

Frozen water pipe hazard

Your heating boiler is designed to provide a warm and comfortable living environment. It is NOT designed to ensure against freezing of water pipes. The boiler is equipped with several safety devices that are designed to shut down the boiler and to prevent it from restarting in the event of various unsafe conditions.

If your boiler remains off for an extended period of time during cold weather, water pipes may freeze and burst, resulting in extensive water damage and conditions in which mold could grow. Certain molds are known to cause respiratory problems, as well as to pose other serious health risks. In case of water damage, immediate measures should be taken to dry out affected areas as quickly as possible to prevent mold from developing.



WARNING

As there are no user-serviceable parts on the boiler, or control, the end-user must not perform service activities of any kind on system components. Failure to heed this warning can cause property damage, severe personal injury or loss of life.

If the building will be unattended for an extended period of time during cold weather, you should...

Shut off the water supply to the building, drain the water pipes and add antifreeze for potable water to drain traps and toilet tanks. Open faucets where appropriate.

or...

Have someone check the building frequently during cold weather and call a qualified service agency if required.

or...

Install a reliable remote temperature sensor that will notify somebody of freezing conditions within the building.

Hazardous Material

Fiberglass wool and ceramic fiber materials



WARNING

Inhaling of fiberglass wool and/or ceramic fiber materials is a possible cancer hazard. These materials can also cause respiratory, skin and eye irritation.

The state of California has listed the airborne fibers of these materials as a possible cancer hazard through inhalation. When handling these materials, special care must be applied.



WARNING

Appliance materials of construction, products of combustion and the fuel contain alumina, silica, heavy metals, carbon monoxide, nitrogen oxides, aldehydes and/or other toxic or harmful substances which can cause serious injury or loss of life and which are known to the State of California to cause cancer, birth defects and other reproductive harm. Always use proper safety clothing, respirators and equipment when servicing or working nearby the appliance.

First aid measures

- If eye contact occurs, flush eyes with water to remove dust. If symptoms persist, seek medical attention.
- If skin contact occurs, wash affected areas gently with soap and warm water after handling.

Suppliers of ceramic fiber products recommend the following first aid measures:

- Respiratory tract (nose and throat) irritation: If respiratory tract irritation develops, move the person to a dust free location.
- Eye irritation: If eyes become irritated, flush immediately with large amounts of lukewarm water for at least 15 minutes. Eyelids should be held away from the eyeball to ensure thorough rinsing. Do not rub eyes.
- Skin irritation: If skin becomes irritated, remove soiled clothing. Do not rub or scratch exposed skin. Wash area of contact thoroughly with soap and water. Using a skin cream or lotion after washing may be helpful.
- Gastrointestinal irritation: If gastrointestinal tract irritation develops, move the person to a dust free environment.

Suppliers of fiberglass wool products recommend the following precautions be taken when handling these materials:

- Avoid breathing fiberglass dust and contact with skin and eyes.
- Use NIOSH approved dust/mist respirator.
- Wear long-sleeved, loose fitting clothing, gloves and eye protection.
- Wash work clothes separately from other clothing. Rinse washer thoroughly.
- Operations such as sawing, blowing, tear-out and spraying may generate airborne fiber concentration requiring additional protection.

Mechanical Room

No combustible materials may be stored in the heating room. The heating boiler may only be set up on a fire-resistant and temperature-resistant floor. No temperature-sensitive pipes or lines may be installed in the floor beneath the heating boiler.

A sufficient supply of fresh air must be provided directly from outdoors into the heating room. Induced ventilation is necessary for heating rooms that are confined or enclosed.

See "Installation and Operating Instructions" for more details.

The temperature in the heating room must not exceed 104°F (40°C) while the system is in operation (in the area approx. 3 ft. (1 m) away from the boiler).

The temperature in the heating room must not fall below 50°F (10°C) while the system is in operation (measured at the inner side of exterior walls).

IMPORTANT

Always follow the most up-to-date local, municipal and building regulations and codes.

Mechanical room conditions



WARNING

Incorrect ambient conditions can lead to damage to the heating system and put safe operation at risk.

Prevent the air from becoming contaminated by homogenate hydrocarbons (e.g. as contained in paints solvents or cleaning fluids) and excessive dust (e.g. through grinding or polishing work). Combustion air for the heating process, and ventilation of the boiler room must be free of corrosive contaminants. To that end, any boiler must be installed in an area that has no chemical exposure. The list to the right indicates the main, currently known sources.

Avoid continuously high levels of humidity (e.g. through frequent drying of laundry).

Never close existing ventilation openings.

IMPORTANT

Components which are not tested with the heating system may damage the heating system or affect its functions. Installation or replacement may only be carried out by a qualified heating contractor.

Sources of combustion and ventilation air contaminants

Areas likely to contain contaminants:

- New building construction
- Swimming pools
- Remodeling areas, hobby rooms
- Garages with workshops
- Furniture refinishing areas
- Dry cleaning/laundry areas and establishments
- Auto body shops
- Refrigeration repair shops
- Metal fabrication plants
- Plastic manufacturing plants
- Photo processing plants
- Beauty salons

Products containing contaminants:

- Chlorine-type bleaches, detergents and cleaning solvents found in household laundry rooms
- Paint and varnish removers
- Hydrochloric acid, muriatic acid
- Chlorine-based swimming pool chemicals
- Spray cans containing chlorofluorocarbons
- Chlorinated waxes and cleaners
- Cements and glues
- Refrigerant leaks
- Calcium chloride used for thawing
- Sodium chloride used for water softening salt
- Permanent wave solutions
- Adhesives used to fasten building products and other similar item
- Antistatic fabric softeners used in clothes dryers

Combustion Air Supply

Codes

Provision for combustion and ventilation air must be made in accordance with applicable local codes.

In the absence of local codes, use:

CSA B365, Installation Code for Solid Fuel Burning Appliances and Equipment (latest edition).

Always use latest edition codes.



WARNING

Failure to provide an adequate supply of fresh combustion air can cause poisonous flue gases to enter living space. Flue gases entering living space can cause carbon monoxide poisoning which can result in severe personal injury or loss of life.



WARNING

Never cover the boiler or store debris or other materials near the boiler, or in any way block the flow of adequate fresh air to the boiler. Never cover the combustion air opening. Advise system operator/ultimate owner accordingly.



WARNING

The boiler must not be located in areas or rooms where chemicals are stored, or aggressive vapors (i.e. bleach, hair spray, methyl chloride, carbon tetrachloride or perchloroethylene) or high dust levels or humidity levels are present. Heat exchanger corrosion might occur and reduce the lifetime of the boiler significantly. If above criteria are not properly observed and boiler damage results, any warranty on the complete boiler and related components will be null and void.

General

This equipment requires fresh air for safe operation.

The boiler location must never be under negative pressure. Exhaust fans, attic fans, or dryer fans may cause air to be exhausted at a rate higher than air can enter the structure for safe combustion.

The heating contractor shall ensure all of the following requirements are met:

- An adequate supply of combustion air must be available to ensure proper combustion.
- Ambient air temperatures must be maintained within safe operating limits.
- When a damper is provided in any opening intended to admit combustion air into the room within which the appliance is installed, the damper shall be interlocked to prevent any boiler from starting before the damper is fully open.
- Each duct used to convey air from the outdoors shall have:
 1. a cross-sectional area throughout its length at least equal to the free area of the inlet and outlet openings which it connects,
 2. making a provision for outside combustion air, the intake shall not be less than 1 ft. (0.3 m) above the anticipated snow level for the location.
- The heating contractor must check with local authorities (municipal building department) for combustion air requirements particular to the area.

See "Installation and Operating Instructions" for more details.

Components of the Biomass Boiler

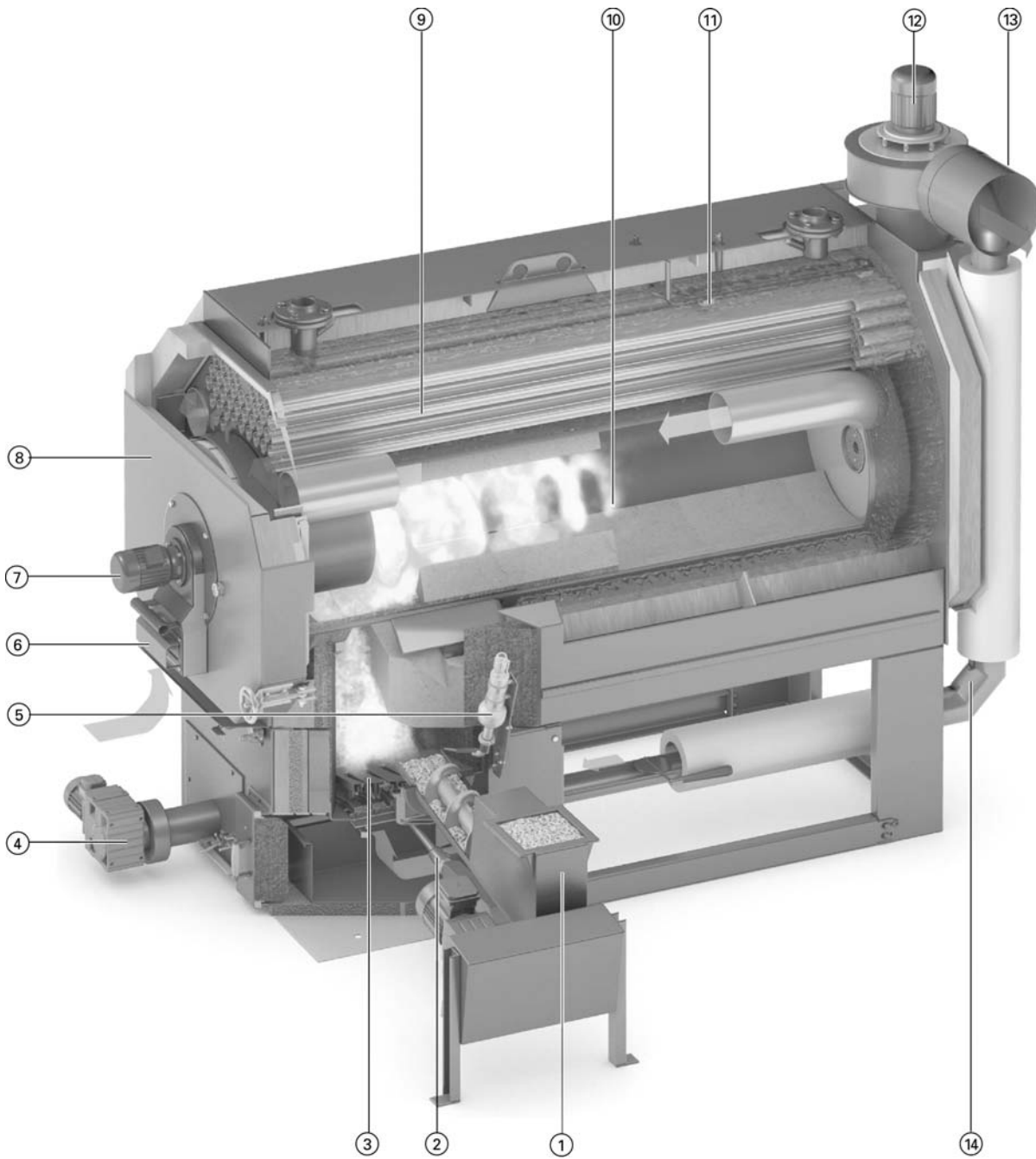

Legend

- | | |
|---|--|
| ① In-feed auger with isolating layer | ⑧ Boiler door |
| ② Drive for moving grate | ⑨ Heat exchanger |
| ③ Moving grate | ⑩ Rotary combustion chamber (Viessmann-patented) |
| ④ Drive for automatic de-ashing system (optional) | ⑪ Safety heat exchanger for thermal safety flush valve |
| ⑤ Igniter | ⑫ Frequency-controlled flue gas exhaust blower |
| ⑥ Controlled combustion air supply system | ⑬ Pneumatic cleaning system (optional) |
| ⑦ Rotary blower (Viessmann-patented) | ⑭ Flue gas recirculation pipe |

Cleaning

Boiler

The heat exchanger, flue gas pipe, and chimney must be cleaned regularly to remove accumulated creosote and ash. Ensure that the heat exchanger, flue gas pipe, and chimney are cleaned at the end of the heating season to minimize corrosion during the summer months. The appliance, flue gas pipe, and chimney must be in good condition.

Regular cleaning and maintenance of the boiler system is of the utmost importance to assure trouble-free operation and to obtain the largest possible output at the best efficiency.

The cleaning intervals listed here are for wood chip fuel material with clinging bark with 0.8% ash content. The cleaning intervals may vary, depending on the fuel, the amount of fine matter and the operating conditions.

With pneumatic cleaning system, after approx. 600 operating hours; without pneumatic cleaning system, after approx. 300 operating hours:

Open the boiler door and clean all heat exchanger with a wire cleaning brush. Use the ash rake to carefully draw the fly ash lying in the rotary combustion chamber to the front.

After approx. 1000 operating hours: Disconnect the power from the flue gas exhaust blower, loosen the butterfly nuts, pull out the motor with impeller and clean the assembly with a broom or wire brush.

IMPORTANT
With pneumatic cleaning system, disconnect the compressed air line before opening the boiler door – danger of injury!

CAUTION
DANGER OF INJURY – be absolutely sure to turn OFF the main switch.

After approx. 300 operating hours: Open the lid across the in-feed auger and clear the slots in the grate.

CAUTION
RISK OF INJURY: Shut the system off before starting any cleaning. Be absolutely sure to wear protective gloves, protective eyewear if required and use the cleaning tools that come with the system (danger of blow-ups, burns and getting crushed)!

Check the level of the ash bin regularly and empty the bin before it is completely full.

IMPORTANT
NEVER operate the boiler without the ash bin.

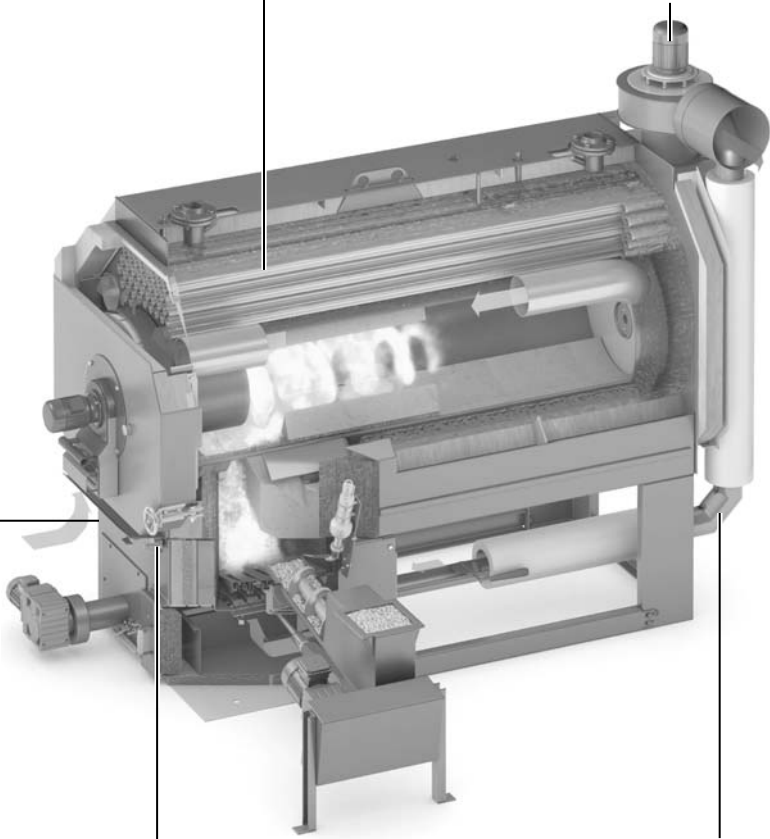

After approx. 1000 operating hours: Clean the recirculated flue gas line.

After approx. 300 operating hours: Loosen and clean the light barriers and the inspection windows on the combustion chamber. Remove dust and ash in the openings.

Cleaning *(continued)***Heat exchanger displacement rods**

The displacement rods improve the heat transmission in the heat exchanger and reduce the temperature of the exhaust gas, thus improving the efficiency of the heating system. They have to be taken out to clean the heat exchanger and put back in after cleaning.

Installing the displacement rods

Insert the displacement rods into the heat exchanger with the thick end first. Push until they are flush with the edge of the tube. Tolerance $\pm 1/4$ " (5 mm).

Removing the displacement rods

Remove the displacement rods with a pair of pliers, as shown above. The heat exchanger should be cleaned at the intervals prescribed so that performance and efficiency are maintained and the displacement rods can be easily removed.

⚠ CAUTION

RISK OF INJURY: Shut the system off before starting any cleaning. Be absolutely sure to wear protective gloves, protective eyewear if required and use the cleaning tools that come with the system (danger of blow-ups, burns and getting crushed)!

Cleaning *(continued)*

Pneumatic cleaning system (optional)

- Operation and maintenance of the air compressor (optional) according to the manual that comes with the system.
- For a field supplied air compressor, the compressor has to be suited for continuous operation or be secured against continuous operation (e.g. timer for limiting running time).
- Continuous operation of the compressor indicates leakage in the air system. Check air supply line and valves for leakage.

Regularly drain condensation water in the compressed air distribution bar.



Shutdown

Boiler

Heat exchanger:

- When the Vitoflex 300-RF is not in operation for a long period (such as for summer breaks), be sure to carefully clean the heat exchanger with a steel brush as required.
- If the heating room is moist or there is any other atmosphere that promotes corrosion (e.g. poor ventilation, residual enamel near the heating room, etc.), spray the heat exchanger with biodiesel after cleaning.
- If there is a danger of frost, empty the heating system or add antifreeze.

Extraction and conveyance systems

When the Vitoflex 300-RF is not in operation for a long period (such as for summer breaks), it is recommended to empty the fuel extraction and conveyance system of all fuel to avoid corrosion of the equipment and decay of the wood fuel. Refill with new fuel after checking the system and before the boiler startup.

Control system

Even when the Vitoflex 300-RF is not in operation for long periods, the power supply to the control system should not be interrupted (do not turn off the main switch).

- The "intermittent control system" switches on the boiler pump for five seconds every 24 hours. This prevents the pump from jamming during long stand stills and prevents expensive repairs.
- Prevent the formation of condensation in the oxygen sensor.
- Extend the service life of the buffer battery.

Ash disposal

- Ashes should be stored in covered metal containers on non-combustible floors away from combustible material.
- Comply with customary laws and local regulations on ash disposal.

Warning Message

1. Eliminate the cause of the warning.
2. Acknowledge the warning message in the controller.

Fault Message



WARNING

Risk of injury due to faults in the heating system that have not been rectified.

In the event of faults, shut down the heating system and safeguard against reconnection.

Immediately notify faults to the responsible body or individual.

Rectify faults immediately.

When rectifying a fault, no-one else should be present in the danger zone around the heating system.

Prior to starting the heating system ensure that no one else is within the danger zone around the heating system.

1. Locate the fault.
2. Check the fault.
3. Eliminate the cause of the fault.
See "Error message table".
4. Acknowledge the fault message on the programming unit.

Fault Message *(continued)*

No.	Fault message	Cause	Remedy
001	Fault: High limit safety cut-out	Setting for set supply temperature is too high	Check the setting for the set supply temperature
		Faulty system component (boiler circuit pump or return valve)	Check boiler circuit pump and temperature maintenance
		Power consumption has suddenly dropped	Check heat draw-off
		--	Undo protective cap on high limit safety cut-out and press reset button (only possible once boiler water temperature is < 70°C)
002	Fault: Water shortage	Leak in heating system	Consult Viessmann Technical Service or heating system installer
		Leak in safety valve	Consult Viessmann Technical Service or heating system installer
003	Fault: Water pressure	Pressure relief valve is faulty (system pressure is too high)	Have a contractor check the pressure relief valve and replace if necessary
004	Fault: Level, extinguishing water	Too little water in the extinguishing water tank	Fill water tank
005	Fault: Thermal contact, rotary fan	Electrical fault on drive motor	Consult a qualified electrician
		Bearing damage	Replace bearing
006	Fault: Thermal contact, infeed grate	Electrical fault on drive motor	Consult a qualified electrician
		Gearbox or bearing damage	Replace gearbox or bearing
007	Fault: Shut-off gate valve sticks	Spring return motor is faulty	Repair or replace spring return motor
		Shut-off gate valve does not reach end position	- Check for trapped foreign bodies and remove if necessary - Check and adjust limit switch
008	Fault: Reversal, rotary lock valve	Rotary lock valve is blocked	Check rotary lock valve for trapped foreign bodies and remove if necessary
009	Fault: Repeat heat-up	Fuel is too damp	Use suitable dry fuel
		Oxygen monitoring detects no combustion	Check oxygen probe, clean, calibrate and replace if necessary
		Combustion chamber fill time is too short, resulting in lack of fuel at the ignition system	Adjust combustion chamber fill time
010	Fault: Light barrier, firebed	Sight glasses are dirty	Remove and clean both sight glasses
		Ash deposits in apertures	Remove dust and ash deposits from the apertures
		Light barrier is dirty or faulty	Clean or replace the light barrier sensors
		Combustion chamber is too full	Check combustion parameters and adjust if necessary
011	Fault: Material shortage	Fuel store is empty	Fill fuel store
		Material blockage	Switch OFF mains isolator and remove material blockage
		Shut-off gate valve sticks	Check shut-off gate valve for ease of operation

Fault Message *(continued)*

No.	Fault message	Cause	Remedy
012	Fault: Temperature level, hydraulics, push floor	Loss of oil at the hydraulic unit	- Check the fittings, lines and cylinders for leaks - Top up the oil
		Pressure switch is incorrectly set or faulty	- Replace pressure switch - Readjust setting for changeover pressure at pressure switch
		Room temperature is too high	- Reduce room temperature - Install oil cooler
013	Fault: Temperature level, hydraulics, silo cover	Loss of oil at the hydraulic unit	- Check the fittings, lines and cylinders for leaks - Top up the oil
		Pressure switch is incorrectly set or faulty	- Replace pressure switch - Readjust setting for changeover pressure at pressure switch
		Room temperature is too high	- Reduce room temperature - Install oil cooler
014	Fault: Reversal, discharge	Motor is overloaded due to blockage (foreign body)	Remove foreign body
		Bearing damage	Check for ease of operation
015	Fault: Reversal, conveyor device	Motor is overloaded due to blockage (foreign body)	Remove foreign body
		Bearing damage	Check for ease of operation
016	Fault: Motor protection, hydraulics, container X	Electrical fault on drive motor	Consult a qualified electrician
		Bearing damage	Replace bearing
017	Fault: Temperature level, hydraulics, container X	Loss of oil at the hydraulic unit	- Check the fittings, lines and cylinders for leaks - Top up the oil
		Pressure switch is incorrectly set or faulty	- Replace pressure switch - Readjust setting for changeover pressure at pressure switch
		Room temperature is too high	- Reduce room temperature - Install oil cooler
018	Fault: Container X, cover closed	Material cover of container is not in end position "open"	Open container cover
019	Fault: No container available	All containers are empty or in a fault state	Provide container with fuel
020	Fault: Changeover unit, time monitoring	Changeover unit was running for more than 5 minutes	- Check limit switch - Check the setting for the changeover unit
021	Fault: External charging	External charging reports a fault	Check and remedy the fault in accordance with message on charging controller
022	Fault: Thermal contact, boiler pump	- Electrical fault or motor overloaded - No water or too little water in the system	- Check system pressure - Consult a qualified electrician
023	Fault: CO CO ₂	External detector reports CO or CO ₂ emission into the boiler room	- Immediately leave the boiler room and ensure ventilation - Consult Viessmann Technical Service

Fault Message *(continued)*

No.	Fault message	Cause	Remedy
024	Fault: Electrostatic filter	Call up possible cause at electrostatic filter controller	Check and remedy the fault in accordance with message on electrostatic filter controller
025	Fault: Boiler supply sensor	Temperature sensor or test cable is faulty	Consult a qualified electrician
026	Fault: Boiler return sensor	Temperature sensor or test cable is faulty	Consult a qualified electrician
027	Fault: Contact sensor, feed	Temperature sensor or test cable is faulty	Consult a qualified electrician
028	Fault: Flue gas sensor, boiler	Temperature sensor or test cable is faulty	Consult a qualified electrician
029	Fault: Cylinder sensor, top	Temperature sensor or test cable is faulty	Consult a qualified electrician
030	Fault: Cylinder sensor, top centre	Temperature sensor or test cable is faulty	Consult a qualified electrician
031	Fault: Cylinder sensor, centre	Temperature sensor or test cable is faulty	Consult a qualified electrician
032	Fault: Cylinder sensor, bottom centre	Temperature sensor or test cable is faulty	Consult a qualified electrician
033	Fault: Cylinder sensor, bottom	Temperature sensor or test cable is faulty	Consult a qualified electrician
034	Fault: Weather-comp. sensor	Temperature sensor or test cable is faulty	Consult a qualified electrician
035	Fault: System sensor	Temperature sensor or test cable is faulty	Consult a qualified electrician
036	Fault: CAN connection, inverter, flue gas fan	Inverter is faulty or there is no supply voltage at the inverter	Consult a qualified electrician or Viessmann Technical Service
037	Fault: Flue gas fan, excess temperature	Motor is overloaded due to excessive supply rate or as a result of bearing damage	Consult a qualified electrician or Viessmann Technical Service
038	Fault: Inverter, flue gas fan Note fault number on inverter	Ongoing fault on the inverter	Consult a qualified electrician or Viessmann Technical Service
039	Fault: Lead break, supply sensor, heating circuit X	Temperature sensor or test cable is faulty	Consult a qualified electrician
040	Fault: Lead break, weather-comp. sensor	Temperature sensor or test cable is faulty	Consult a qualified electrician
041	Fault: Lead break, weather-comp. sensor	Temperature sensor or test cable is faulty	Consult a qualified electrician
042	Fault: Short circuit, weathercomp. sensor	Temperature sensor or test cable is faulty	Consult a qualified electrician
043	Fault: CAN connection, controller module X	Controller module is faulty or there is no supply voltage at the controller module	Consult a qualified electrician or Viessmann Technical Service
044	Fault: Safety limit switch, conveyor devices	Service hatch on a conveyor device is open	Close service hatch
045	Fault: Motor protection, conveyor devices	Motor is overloaded due to blockage (foreign body)	Remove foreign body
		Bearing damage	Check for ease of operation

Fault Message *(continued)*

No.	Fault message	Cause	Remedy
046	Fault: Emergency stop actuated	Emergency stop button is engaged	Reset emergency stop button
047	Fault: High limit safety cut-out, fuel store	Fire in fuel store	Notify fire service
048	Fault: Safety limit switch, conveyor devices, charging chamber	Service hatch on a conveyor device is open	Close service hatch
049	Fault: Motor protection, conveyor device, charging chamber	Motor is overloaded due to blockage (foreign body)	Remove foreign body
		Bearing damage	Check for ease of operation

Warning messages

No.	Fault message	Cause	Remedy
001	Warning: Motor protection, ash removal	Motor is overloaded due to blockage (foreign body)	Remove foreign body
		Bearing damage	Check for ease of operation
002	Warning: Maximum ash removal runtime exceeded	Ash removal light barrier is dirty	Clean transmitter and receiver of the light barrier
		Ash removal light barrier is faulty	Consult Viessmann Technical Service
003	Warning: System running without O ₂ control	- Lambda probe is severely contaminated or faulty - O ₂ signal converter is faulty	Consult Viessmann Technical Service
004	Warning: Feed tube warm	Minimum fuel supply is set too low	Increase minimum cycle of feed screw conveyor
		Setting for switching threshold was selected too low	Check set limit temperature for feed pipe and adjust if necessary (standard value = 70°C)
005	Warning: Light barrier, feed	Light barrier is dirty or faulty	Clean or replace the light barrier sensors
006	Warning: Transverse screw overfilled	Lower light barrier for transverse screw is dirty or obstructed by bridging	- Clean or replace the light barrier sensors - Remove bridging in trough

Fault Message *(continued)*

Warning messages			
No.	Fault message	Cause	Remedy
007	Warning: Transverse screw of container X overfilled	Upper light barrier for transverse screw is dirty	Clean or replace the light barrier sensors
		Shutdown delay of lower light barrier is set too high	Check setting and correct if required
		Material infeed in hydraulics emergency mode is set too high	Adjust cycle settings
008	Warning: Container X absent	Container is not correctly connected	Connect container
009	Warning: Container X, cover closed	Material cover of container is not in end position "open"	Open container cover
010	Warning: Container X empty	Container is empty	Fill container
011	Warning: Container, push floor in emergency mode	Lower light barrier for transverse screw is dirty or obstructed by bridging	- Clean transmitter and receiver of the light barrier - Remove material bridging in trough
012	Warning: E filter, bypass enabled	Electrostatic filter for bypass has been active for over 30 minutes	Check and remedy warning in accordance with message on electrostatic filter for bypass
013	Warning: E filter, cleaning enabled	Electrostatic filter for cleaning has been active for over 30 minutes	Check and remedy warning in accordance with message on electrostatic filter for cleaning
014	Warning: Control panel temperature sensor faulty	Temperature sensor or test cable is faulty	Consult a qualified electrician
015	NB: Max. ctrl panel temp. exceeded	Intake filter for control panel fan is dirty	Clean filter mesh
		Ambient temperature is too high	Ensure adequate room ventilation
016	Warning: Silo X empty	Fuel store is empty	Fill fuel store
017	Warning: Probe X blocked	Probe X is empty	Fill fuel store
018	Warning: No CAN connection to charging chamber	Charging module is faulty or there is no supply voltage at the charging module.	Consult a qualified electrician or Viessmann Technical Service

Adjusting the Fuel Supply and Air Supply



WARNING

Risk of poisoning from carbon monoxide and carbonization gas as a result of incomplete combustion caused by overfilling with fuel. Ensure that the fuel supply and air supply are adjusted correctly. When changing to a different fuel, adjust the parameters to suit the new fuel.

The boiler is commissioned by Viessmann engineers. As part of this process, the boiler will be adjusted so that the available fuel in conjunction with the amount of air supplied will result in optimum combustion.

Note: Overloading the combustion chamber leads to ash glazing on the fireproof interior lining and thereby to premature damage to the combustion chamber. The lining, grates and metal parts in the combustion chamber are wearing parts. Excessively high loads will cause the parts to wear more quickly. Overloading the system will also have an increased impact on the boiler, dust extractor and chimney causing them to wear more quickly too. Ensure that the fuel supply and air supply are adjusted correctly.

Note: The composition of the fuel may differ in terms of particle size, type of wood, moisture content, bulk density and other characteristics. When changing to a different fuel, adjust the parameters to suit the new fuel. This will ensure optimum combustion of each fuel type. The combustion chamber is not overloaded and the emission values are observed.

Adjusting the Ash Removal

The amount of ash in the combustion chamber depends on the ash content of the fuel. The Vitoflex 300-RF removes ash automatically by means of a moving grate. The intervals at which the grate is moved can be adjusted to individual requirements. The ash is discharged automatically via the ash removal system. The ash removal cycle is matched to the relevant fuel type during commissioning. Check the pause times of the ash removal cycle during operation. The Boiler technician or suitably trained persons must then adjust the times to suit the relevant fuel.

When setting the ash removal cycles, observe the following principle:

- Long pause time between ash removal events. Small fragments may break away from the refractory concrete in the combustion chamber as a result of normal wear. These concrete fragments are removed by the ash removal system. The breaking away of small concrete fragments has no negative impact on the service life of the combustion chamber.

Visual Inspection of Combustion

During operation, the controller controls, regulates and monitors all components and system parts automatically.

CAUTION

Risk of burns due to hot machine components. Only touch handles and identified parts. Never touch sight glasses or their retainers. These components are connected directly to the combustion chamber.

Check flames in the combustion chamber through the sight glass.

The ideal flame is yellow to light yellow. This indicates normal combustion in which the fuel burns cleanly.

Unjamming the Ash Removal Screw Conveyor

CAUTION

Risk of crushing by and entanglement in the ash removal screw conveyor. Never reach in through the maintenance cover.

Note: Wear personal protective equipment. Always wear a face mask when handling ash or slag.

Requirements:

- The system is switched off.
- The firebed is completely burned down. Check the firebed through the sight glass.

1. At the programming unit, switch the system to manual mode in the sub-area "Fuel", under "Ash removal, combustion chamber".

2. WARNING

There is a risk of deflagration when the combustion chamber door is opened. Poking around in the firebed leads to oxygenation, which can produce a flash. Both can result in severe burns. Never open the combustion chamber door during operation. Before opening the combustion chamber door, ensure that you are standing in a safe place. Never poke around in the firebed.

3. At the programming unit, alternately tap on "clockwise" and "anti-clockwise". The ash removal screw conveyor runs forwards and backwards alternately. This action will unjam the ash removal screw conveyor.
4. Stop the movement of the ash removal screw conveyor. The ash removal screw conveyor comes to a halt.
5. Open the inspection cover.

6. CAUTION

Hot ash and slag may result in burns. Wear protective gloves when handling ash and slag. Remove large bits of slag with a poker or similar.

7. Close the inspection cover.
8. On the programming unit, switch automatic mode back on. The ash removal screw conveyor is now unjammed.

Fault Messages



“Current” tab



“History” tab

In the footer, tap on the button. The fault message screen opens up.

Current fault messages

This screen displays unprocessed fault messages.

Display	Description
“Time/Date”	Time at which the fault message occurred
“Text”	Displays the fault text Fault: Serious system fault Warning: Information or minor system fault
“Acknowledge”	You can use this button to acknowledge the fault message after the fault has been rectified. Tapping on “Acknowledge” acknowledges all currently unacknowledged fault messages. Once acknowledged, the fault message is then only displayed under History.

All fault messages

All fault messages, including those already acknowledged, are shown on this screen. The latest fault message is always at the top. Once there are 100 fault messages, the oldest message is deleted when a new one is generated.

Note: Acknowledged messages are displayed in grey. Unacknowledged messages are displayed in red.

Display	Description
“Time/Date” Come	Time at which the fault message occurred
“Time/Date” Go	Time at which the fault message was acknowledged
“Text”	Displays the fault text Fault: Serious system fault Warning: Information or minor system fault

Information on Maintenance

CAUTION

Fuel emissions and incomplete combustion lead to the formation of life threatening carbon monoxide (CO). Carbon monoxide is a colourless, odourless and tasteless, extremely poisonous gas, which in sufficient concentration results in death.
Always wear a mobile CO monitor when entering the fuel store, rooms where fuel is transported and the boiler room. If the monitor sounds an alarm, leave the room immediately.
Observe the safety instructions for the fuel store.

CAUTION

Serious injuries or risk to life through electric shock.
Before starting any work on electrical components, switch OFF the heating system at the mains isolator. Safeguard the system against reconnection.

CAUTION

Risk to life if the system starts up unexpectedly.
Before restarting the system, ensure that no persons are in the danger zone around the system.

WARNING

Missing protective covers pose a risk of crushing and cutting injuries through entanglement in rotating or moving parts.
After completing maintenance work, ensure that all protective covers are re-installed correctly.

WARNING

Risk of burns due to hot system components.
Only carry out maintenance work when the system has cooled down.

Note: Wear personal protective equipment.
Always wear a face mask when handling ash or slag.

Responsible Groups

Maintenance jobs are carried out by various groups of personnel. All personnel charged with working on the heating system must be instructed with reference to the documentation supplied.
The maintenance and cleaning schedules listed below use the following symbols for each group.

Symbol	Description
O	Boiler technician
V	Viessmann Technical Service
HC	Viessmann Technical Service

Annual General Inspection

Viessmann Technical Service is happy to carry out the inspection and maintenance of your heating system and can provide a quote for a maintenance contract.
Contact the Technical Service department for an annual general inspection or if you wish to change fuel.
Costs for inspection and maintenance are met by the operator.

Servicing the Boiler

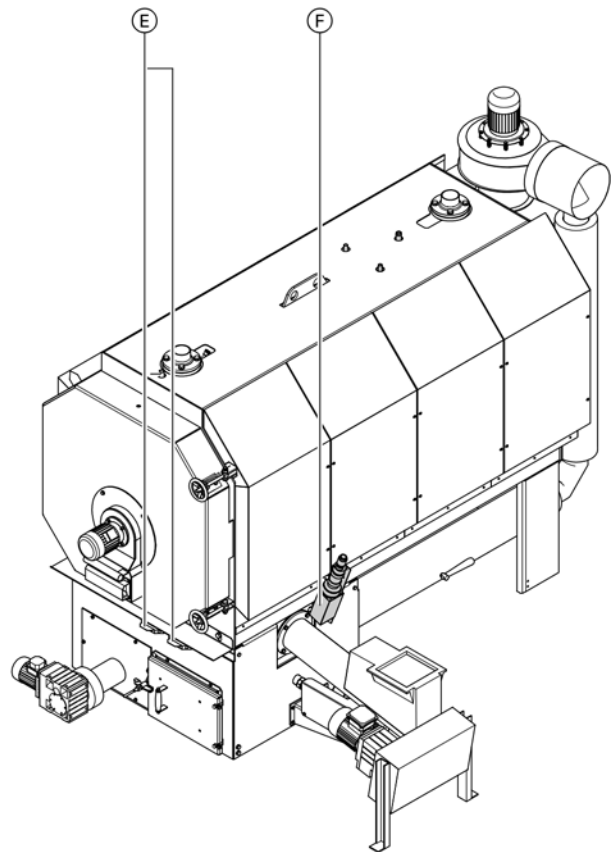
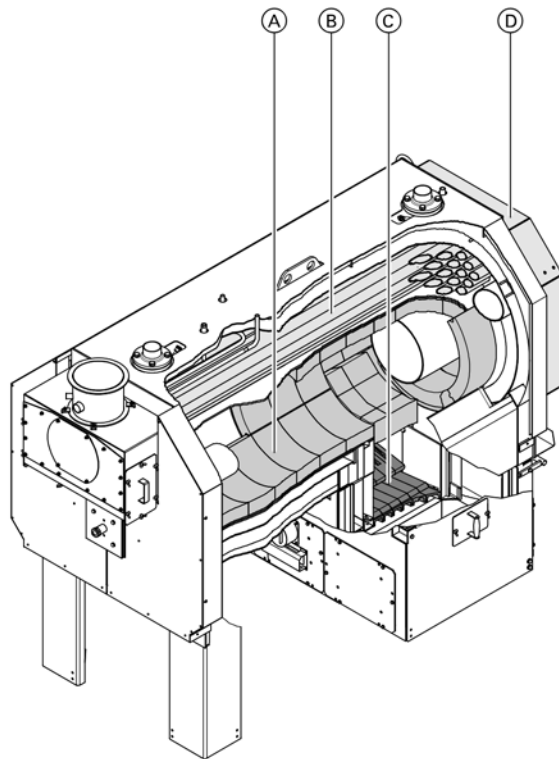

Component, activity	Interval			
	300 hours	900 hours	Every 6 months	Annually
Boiler				
Service electrical safety equipment.				V
Service safety equipment on the water side.				HC
Check the respective alignment of the transmitters and receivers of light barriers (E).		O		
Combustion chamber (A)				
Check infeed grate (C) for damage.				V
Check the gasket of boiler door (D) for wear.				HC
Check segment blocks (A) for damage.			O	
Check combustion chamber (A) for slag deposits and remove slag if necessary.			O	
Ash container (optional)				
Check ash container connection for tightness.	O			

Servicing the Boiler *(continued)*

Component, activity	Interval			
	300 hours	900 hours	Every 6 months	Annually
Heat exchanger (B)				
Check system pressure at pressure gauge (minimum pressure, water shortage).	O			
Check thermally activated safety valve for tightness.	O			
Ignition system (F)				
Check ignition pipe for blockages and clean if necessary.		O		
Pneumatic cleaning system (optional)				
Check valves for tightness.				O
Compressor system (optional)				
Service the compressor system in accordance with the compressor operating instructions. Observe information on compressor.	O (Interval in accordance with the compressor operating instructions)			
Flue gas path (optional)				
Check chimney draught regulator for ease of operation.		O		

Information on the compressor

If the compressor is operating continuously, this indicates that there is a leak in the compressed air system. Check supply lines and valves for leaks. In the case of on-site supply of compressed air, ensure that the compressor is suitable for continuous operation or can be prevented from operating continuously.

Cleaning the Boiler

Information on cleaning the boiler

IMPORTANT

Dirt and deposits can damage the boiler. Clean the outside of the heating system as required. Have the inside of the heating system cleaned at least once a year by contractors.

Note: Cleaning work may also be carried out by a local chimney sweep.

Prior to cleaning

Switch off the system via the button.

Then start the cleaning function via the  button. The function can be found in the "Charging" parameters/ under the "Ash removal" tab, see operating instructions.

Cleaning function enabled:

- Flue gas fan operates at 50%.
- Infeed grate is moving.

Cleaning the Boiler *(continued)*

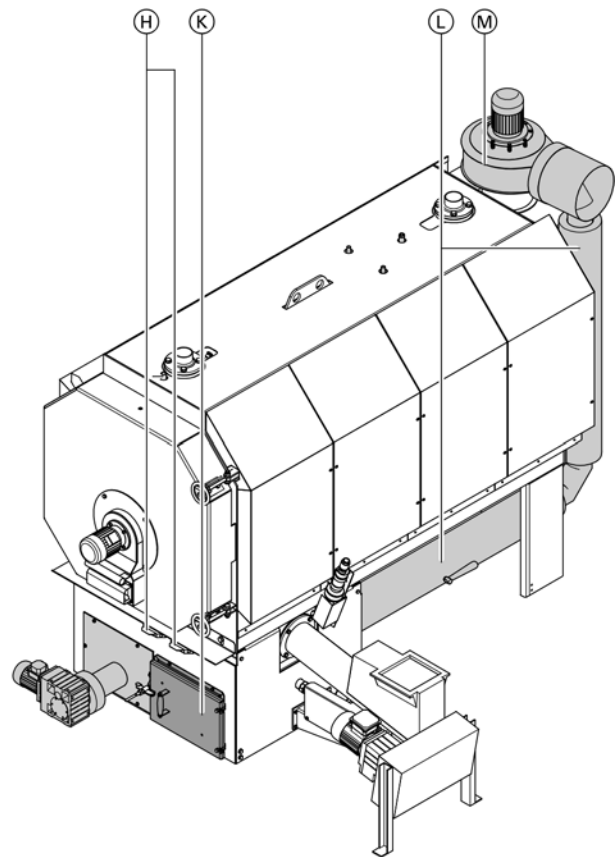
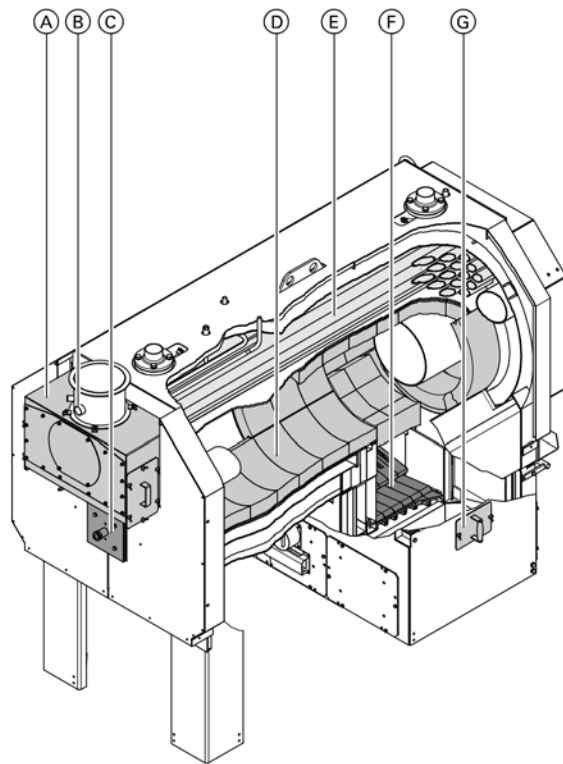

Component, activity	Interval			
	100 hours	300 hours	900 hours	Annually
Boiler				
Clean combustion chamber (D) and flue gas collector (A) plus entire flue gas path. Observe information on flue gas path.	--	--	O	--
Combustion chamber (D)				
Open inspection cover (C) and check infeed grate F for contamination and slag deposits, clean if necessary. Cleaning interval depends on fuel and fuel quality.	--	O	--	--
Check sight glass (C) and the sight glasses for light barriers (H) for contamination and clean if necessary. When doing so, remove any deposits from the apertures for the sight glasses.	--	O	--	--
Remove ash below infeed grate (F).	--	O	--	--
Heat exchanger (E)				
Clean heat exchanger pipes. Observe information on displacer rods.	--	--	O	--
Clean Lambda probe (B).	--	--	O	--
Clean flue gas fan (M).	--	--	--	O

Cleaning the Boiler *(continued)*

Component, activity	Interval			
	100 hours	300 hours	900 hours	Annually
Ash removal				
Without automatic ash removal: Open both cleaning hatches (K) and empty both ash pans. Cleaning the interior.	O	--	--	--
With automatic ash removal (optional): Open cleaning hatch (K) and empty ash pan. Cleaning the interior.	--	--	X	--
Recirculation line (L)				
Clean recirculation line (L). Observe information on recirculation line.	--	--	O	--
Check seals on recirculation line (L) and check maintenance cover for leaks.	--	--	O	--
Pneumatic cleaning and compressor system				
Drain condensate from the compressor system.	--	O	--	--

Information on flue gas path

Check the lines and pipes of the flue gas path for tightness after cleaning and every six months.

Information on displacer rods

- Special tongs for removing the displacer rods are provided with the boiler.
- Insert with the wide end of the displacer rods leading.
- Insert the displacer rods flush with the boiler tube floor ± 1/2 in. (± 5 mm).
See information sheet on fitting the displacer rods.

Information on flue gas recirculation line

Check the flue pipe and the maintenance cover for leaks after each cleaning.
No gas must escape when the boiler is in operation.

Servicing the Flue Gas Dust Extractor (optional)

Note: Only operate the boiler with the ash box installed.

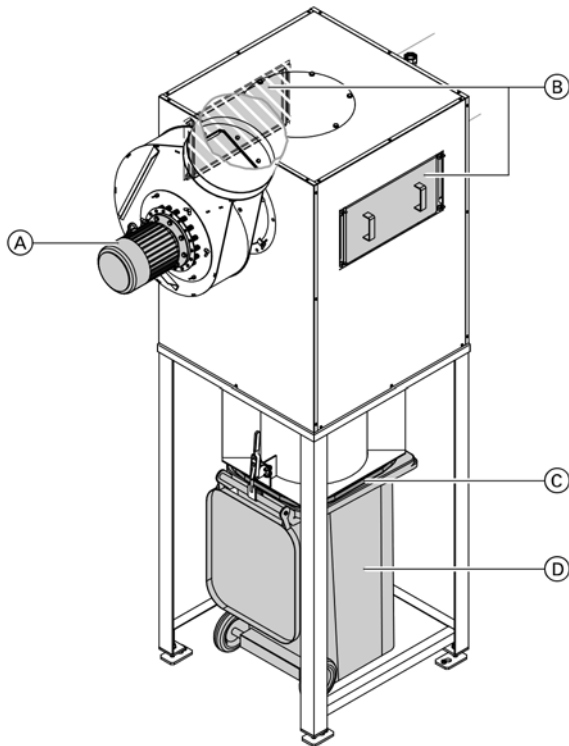

Component, activity	Interval			
	300 hours	1200 hours	Every 6 months	Annually
Flue gas fan (A) Disconnect plug on motor. Undo wing nuts and extract motor together with impeller. Clean with a brush or wire brush.	--	--	--	O
Interior Open covers (B) and clean the guide blades of the flue gas dust extractor with a hand brush.	--	O	--	--
Ash box Check gaskets (C).	--	--	O	--
Empty ash box (D) underneath the flue gas dust extractor. Tip: Check the fill level of the ash box daily. Note: Only operate the boiler with the ash box installed.	O Interval depends on the fuel and size of the ash box.			

Servicing the Conveyor Devices

WARNING

Risk of serious or fatal injury through becoming trapped or crushed by moving parts. Before starting any maintenance work on the conveyor devices, switch **OFF** the heating system at the mains isolator. Safeguard the system against reconnection.

WARNING

Risk of being crushed, cut or entangled by rotating or moving parts as a result of missing protective covers. After completing maintenance work on the conveyor devices, ensure that all protective covers are re-installed correctly.

Notes: All geared motors of the conveyor devices are maintenance-free.
Only use non-combustible lubricants.

Activity

- We recommend changing the lubricant or oil every 20,000 hours run or every 3 years.
- Lubricate all flanged bearings and other lubricating points with lithium soap grease as required.
The interval depends on the installation position and the fuel used.
- Check chain drives for wear, retighten and lubricate with chain oil, as required.
- Check all screws for tightness.
- Check all discharge points from the pellet silo or fuel store annually for damage and contamination.
Remove any foreign bodies.
- Horizontal discharge system:
Check and lubricate articulated arms, articulated screws, tension springs and tensioning chains.
Adjust articulated arms if required.
- Funnel discharge:
Lubricate sealing washer between the discharge casing and geared motor and the universal joint of the screw conveyor.
- Push rod discharge system:
Service the hydraulics in accordance with the operating instructions for the hydraulic unit.



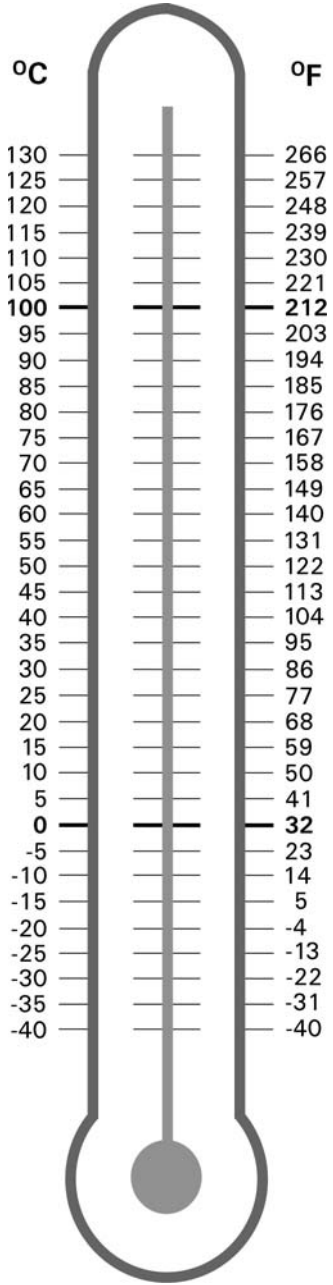

Printed on environmentally friendly
(recycled and recyclable) paper.

Technical information subject to change without notice.

Viessmann Manufacturing Company Inc.
750 McMurray Road
Waterloo, Ontario • N2V 2G5 • Canada
TechInfo Line 1-888-484-8643
1-800-387-7373 • Fax (519) 885-0887
www.viessmann.ca • info@viessmann.ca

Viessmann Manufacturing Company (U.S.) Inc.
45 Access Road
Warwick, Rhode Island • 02886 • USA
TechInfo Line 1-844-649-5886
1-800-288-0667 • Fax (401) 732-0590
www.viessmann-us.com • info@viessmann-us.com