

# Installation and Service Instructions

for use by heating contractor



BMS communication with heating systems via BACnet  
WAGO BACnet/IP with MS/TP router gateway

## WAGO BACnet/IP WITH MS/TP ROUTER GATEWAY

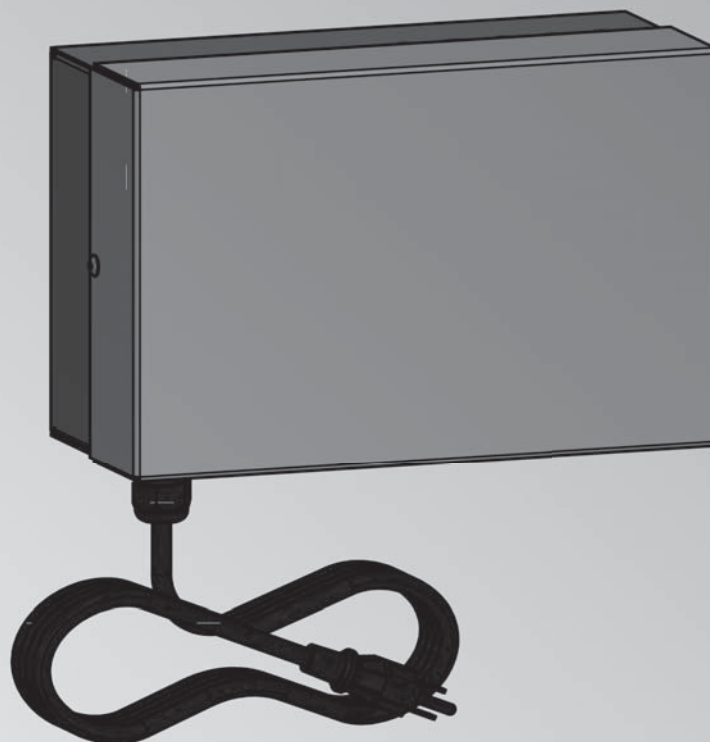

*Product may not be exactly as shown*

**IMPORTANT**

Read and save these instructions for future reference.

## Safety, Installation and Warranty Requirements

Please ensure that these instructions are read and understood before commencing installation. Failure to comply with the instructions listed below and details printed in this manual can cause product/property damage, severe personal injury, and/or loss of life. Ensure all requirements below are understood and fulfilled (including detailed information found in manual subsections).

### ■ Product documentation

Read all applicable documentation before commencing installation. Store documentation near boiler in a readily accessible location for reference in the future by service personnel.

► *For a listing of applicable literature, please see section entitled "Important Regulatory and Safety Requirements".*



### ■ Warranty

Information contained in this and related product documentation must be read and followed. Failure to do so renders the warranty null and void.



### ■ Licensed professional heating contractor

The installation, adjustment, service and maintenance of this equipment must be performed by a licensed professional heating contractor.

► *Please see section entitled Safety and "Important Regulatory and Installation Requirements".*



### ■ Advice to owner

Once the installation work is complete, the heating contractor must familiarize the system operator/ultimate owner with all equipment, as well as safety precautions/requirements, shutdown procedure, and the need for professional service annually before the heating season begins.

	Page
<b>Safety</b>	<b>Safety, Installation and Warranty Requirements.....2</b>
	Product documentation .....2
	Licensed professional heating contractor .....2
	Advice to owner .....2
	Warranty.....2
<b>General Information</b>	<b>Important Regulatory and Installation Requirements ..... 4</b>
	Approvals.....4
	Codes.....4
	Working on the equipment.....4
	Power supply .....4
	<b>About these Installation Instructions .....4</b>
<b>Installation</b>	<b>Intended Use ..... 5</b>
	<b>Product Information.....5</b>
	<b>Spare Parts Lists .....5</b>
	<b>Mounting the Gateway .....6</b>
	<b>Preparing for Installation.....7</b>
	<b>Quick Start Guide WAGO BACnet/IP with MS/TP Router .. 8</b>
	<b>Process Overview..... 12</b>
	<b>Installing the Module ..... 12</b>
	<b>Connections and Operating Elements ..... 13</b>
	<b>Connecting and Releasing Cores..... 15</b>
	<b>Establishing the CAN Bus Connection ..... 16</b>
	<b>Connecting the Plug-in Attachment ..... 18</b>
	<b>Establishing the Connection to the BACnet/IP Gateway .. 19</b>
	<b>Connecting the Gateway to the Power Supply Unit.....20</b>
	<b>Power Supply .....21</b>
	<b>Commissioning the Gateway.....22</b>
	<b>Dismounting the Terminals .....22</b>
	<b>Dismounting the Gateway .....23</b>
	<b>Dismounting the Power Supply .....23</b>
<b>Specifications</b>	<b>Gateway .....24</b>
	<b>Power Supply .....25</b>
	<b>BACnet/IP to MS/TP Router Specification.....26</b>
<b>Additional Information</b>	<b>Final Decommissioning and Disposal ..... 30</b>

## Important Regulatory and Installation Requirements

### Approvals

Viessmann boilers, burners and controls are approved for sale in North America by CSA International.

### Codes

The installation of this unit shall be in accordance with local codes. In the absence of local codes, use:

- CSA C22.1 Part 1 and/or local codes in Canada
- National Electrical Code ANSI/NFPA 70 in the U.S.

Always use latest editions of codes.

The heating contractor must comply with the Standard for Controls and Safety Devices for Automatically Fired Boilers, ANSI/ASME CSD-1 where required by the authority having jurisdiction.

### Working on the equipment

The installation, adjustment, service, and maintenance of this product must be done by a licensed professional heating contractor who is qualified and experienced in the installation, service, and maintenance of hot water boilers. There are no user serviceable parts on the boiler, burner, or control.

### Power supply

Install power supply in accordance with the regulations of the authorities having jurisdiction or, in absence of such requirements, in accordance with National Codes. Viessmann recommends the installation of a disconnect switch to the 120V power supply outside of the boiler room.

Ensure main power supply to equipment, the heating system, and all external controls have been deactivated. Close main oil or gas supply valve. Take precautions in both instances to avoid accidental activation of power during service work.

- ▶ Please carefully read this manual prior to attempting installation. Any warranty is null and void if these instructions are not followed.

For information regarding other Viessmann System Technology componentry, please reference documentation of the respective product.

We offer frequent installation and service seminars to familiarize our partners with our products. Please inquire.

- ▶ The completeness and functionality of field supplied electrical controls and components must be verified by the heating contractor. These include low water cut-offs, flow switches (if used), staging controls, pumps, motorized valves, air vents, thermostats, etc.

	<p><b>! WARNING</b></p> <p>Turn off electric power supply before servicing. Contact with live electric components can cause shock or loss of life.</p>
--	--

## About these Installation Instructions

- ! Take note of all symbols and notations intended to draw attention to potential hazards or important product information.**

 <p><b>WARNING</b></p>
<p>Warnings draw your attention to the presence of potential hazards or important product information.</p>

 <p><b>CAUTION</b></p>
<p>Cautions draw your attention to the presence of potential hazards or important product information.</p>

<p><b>IMPORTANT</b></p>
-------------------------



- ▶ Indicates an imminently hazardous situation which, if not avoided, could result in death, serious injury or substantial product/property damage.
- ▶ Indicates an imminently hazardous situation which, if not avoided, may result in minor injury or product / property damage.
- ▶ Helpful hints for installation, operation or maintenance which pertain to the product.
- ▶ This symbol indicates to note additional information
- ▶ This symbol indicates that other instructions must be referenced.

## Intended Use

### Intended use

The gateway is only intended to be installed and operated in conjunction with Viessmann control units, with due attention paid to the associated installation, service and operating instructions. The gateway may only be used in systems with supported Viessmann heat and power generators.

The gateway can only be used with the user and communication

interfaces defined in the product documentation for the following purposes:

- To monitor systems
- To operate systems
- To optimize systems

With regard to the communication interfaces, ensure on site that the system requirements specified in the product documentation are met at all times for every transfer medium employed. Only use the specified components for the power supply (e.g. power supply units).

Intended use presupposes that a fixed installation in conjunction with permissible, system-specific components has been carried out.

Commercial or industrial use for a purpose other than the monitoring, operation and optimization of supported, approved systems shall be deemed inappropriate.

Incorrect usage or operation of the appliance (e.g. the appliance being opened by the system user) is prohibited and will result in an exclusion of liability. Incorrect usage also occurs if the components in the Viessmann system are modified from their intended function.

## Product Information



The WAGO BACnet/IP gateway is used to connect Viessmann control units to BACnet systems. For supported devices and other valid product documentation, use the QR code on the left.

### Functions

The system user can use the following functions via the gateway when connected to a BACnet system:

- Transferring heating system operating states
- Setting heating system parameters
- Relaying fault and maintenance messages

## Spare Parts Lists

Information about spare parts can be found at [www.viessmann.com/etapp](http://www.viessmann.com/etapp) or in the Viessmann spare part app.

## Mounting the Gateway

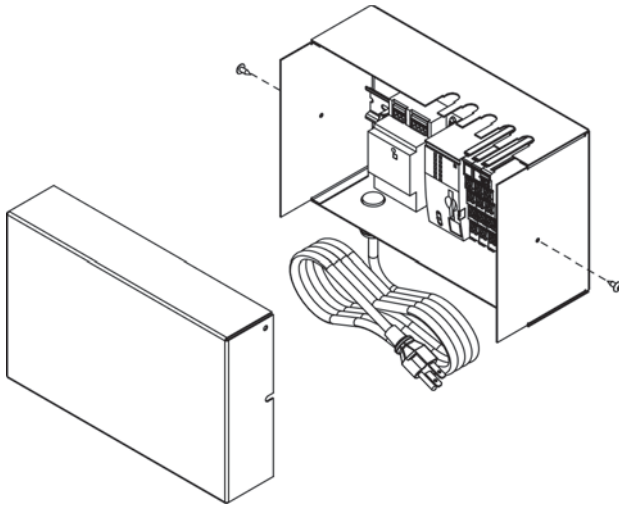

1. Loosen the retaining screws from the extension kit enclosure (do not remove).
2. Remove cover and set aside.

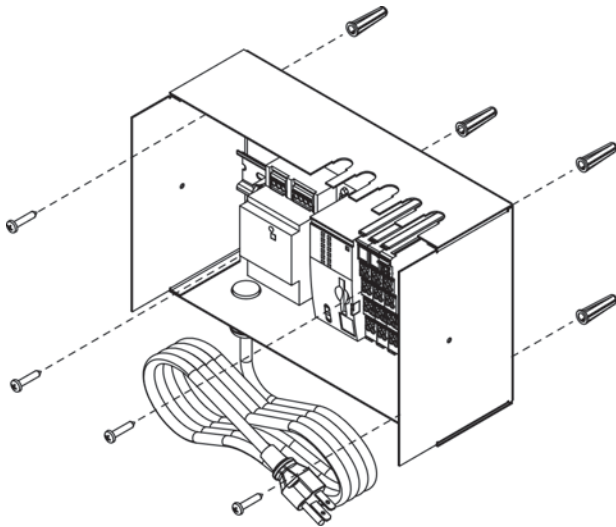

3. Mount the extension module enclosure to the wall using the appropriate hardware.

# Preparing for Installation

## WAGO BACnet gateway system overview

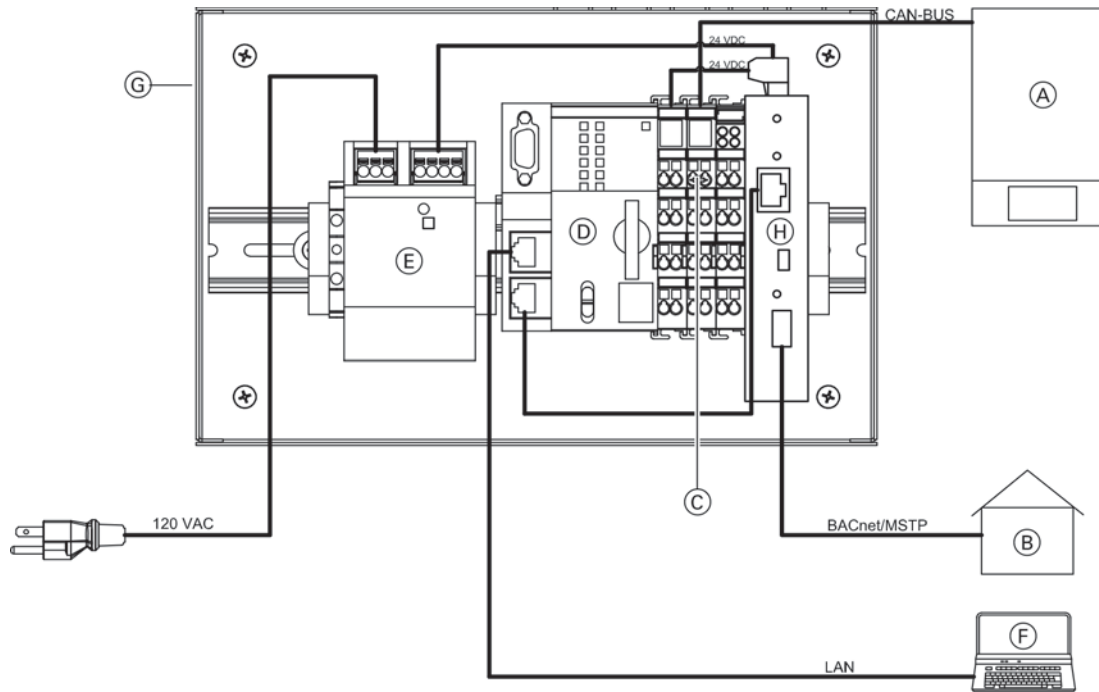

**Legend**

- (A) Viessmann boiler
- (B) Building management system
- (C) Terminator 120 Ω
- (D) Gateway
- (E) Power supply unit
- (F) Laptop with web browser and WAGO Web-Visu
- (G) Module enclosure
- (H) BACnet IP to MS/TP router

# Quick Start Guide WAGO BACnet/IP with MS/TP Router

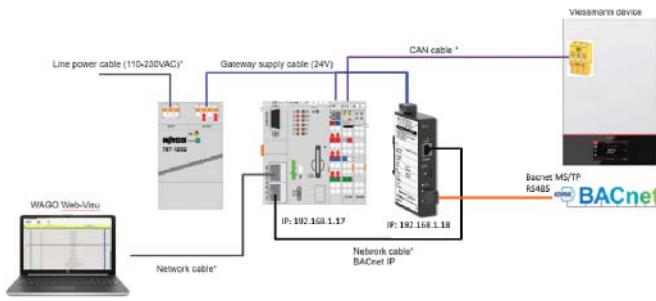

## Install WAGO Gateway

Power up and connect WAGO Gateway to heat generators via CAN-Bus (91 plug).

- Power Supply 24VDC (116 mA, 2.8 W)
- Polarity sensitive (H, and L)
- Daisy chain using (ISO 11898-2, twisted pair cable, shielded, or CAT5 / CAT7)
- End resistors (or dip switch) on both ends of the daisy chain only

**Projekt Informations**

Projekt Name:

Notes field:

---

**Passwords**

---

**Unit system**

---

**Language**

---

**Application type**

---

**Heartbeat monitoring**

## Web Visualisation - Discover Boilers add points

**Note:** Commission your boiler(s) before configuring the automation gateway

Open web browser to <https://192.168.1.17> (user / user)

## Project Settings

Navigate to General / Project Settings

- Select Units (Metric / Imperial)
- Select Application Type (Single or Multiple Devices)
- Heartbeat Monitoring
  - Enabled: BMS must write to "External Request (MV-1)" a value of "3" for BACnet cyclically, at least once per 10 sec. or heat generator reverts to internal control.
  - Disabled: "External Request (MV-1)" does not need to be written cyclically (just once). If connection to BMS is interrupted, the heat generator continues to adopt the setpoint that was written last.



# Quick Start Guide WAGO BACnet/IP with MS/TP Router *(continued)*

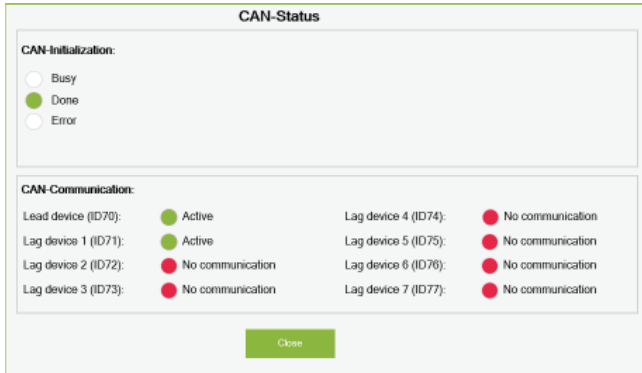

### Add Data points

Navigate to Datapoints / CAN-Status

Make sure you see all the heat generators you want to add to the system

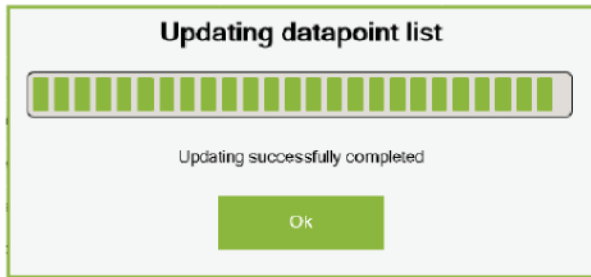

Select "Show Datapoints" and Confirm action to discover points

Select the points you want to add to the BMS

**Note:** You must do this step for each heat generator

No.	Selection	Group function	Datapoint name	Tech. reference	Unit	Value	Read/write permissions	BACnet® - Type Address
1	<input checked="" type="checkbox"/>	Automation gateway	Connection to the heat generator	---	Status	1	ro	BI-1
2	<input checked="" type="checkbox"/>	External request	Burner modulation set point	525	Percent	0.0	rw	AV-1
3	<input checked="" type="checkbox"/>	External request	Flow temperature set point	1604	°C	0.0	rw	AV-2
4	<input checked="" type="checkbox"/>	External request	External demand	921.0	Status	0	rw	MV-1
5	<input checked="" type="checkbox"/>	External request	External demand: Status	921.1	Status	0	ro	MI-1
6	<input type="checkbox"/>	External request	Set DHW temperature	1167	°C	0.0	rw	AV-3
7	<input checked="" type="checkbox"/>	External request	DHW operating program: Set	538.0	Status	0	rw	MV-2
8	<input checked="" type="checkbox"/>	External request	DHW operating program: Actual	538.1	Status	0	ro	MI-2
9	<input checked="" type="checkbox"/>	External request	Operating program, heat generator: Set	1605.0	Status	0	rw	MV-3
10	<input checked="" type="checkbox"/>	External request	Operating program, heat generator: Actual	1605.1	Status	0	ro	MI-3
11	<input checked="" type="checkbox"/>	External request	HC1 set	537.0	Status	0	rw	MV-4
12	<input type="checkbox"/>	External request	HC1 actual	537.1	Status	0	ro	MI-4
13	<input type="checkbox"/>	External request	HC1: Set temp.	1627.0	°C	0.0	rw	AV-4
14	<input type="checkbox"/>	External request	HC2 set	1612.0	Status	0	rw	MV-5
15	<input type="checkbox"/>	External request	HC2 actual	1612.1	Status	0	ro	MI-5
16	<input type="checkbox"/>	External request	HC2: Set temp.	1628.0	°C	0.0	rw	AV-5
17	<input type="checkbox"/>	External request	HC3 set	1613.0	Status	0	rw	MV-6
18	<input type="checkbox"/>	External request	HC3 actual	1613.1	Status	0	ro	MI-6
19	<input type="checkbox"/>	External request	HC3: Set temp.	1629.0	°C	0.0	rw	AV-6
20	<input type="checkbox"/>	External request	HC4 set	1614.0	Status	0	rw	MV-7
21	<input type="checkbox"/>	External request	HC4 actual	1614.1	Status	0	ro	MI-7

**Quick Start Guide WAGO BACnet/IP with MS/TP Router** *(continued)*



Configuration   Advanced   Routing   Security   Status   BDT   FDT

Device Name	VI-WAGO-MSTP-Rtr	
Device Instance	99018	
Device Location	location	Advanced
Ethernet Network	0	
BACnet/IP UDP Port 1	BAC0	
BACnet/IP Network 1	1	
IP Assigned By	FIXED	Status
IP Address	192.168.1.18	
IP Subnet	24	
IP Gateway	192.168.1.1	Routing Table
MS/TP MAC	1	
MS/TP Network	2001	
Max Masters	127	
Max Info Frames	100	
MS/TP Baudrate	38400	
MS/TP Tolerance	<input type="radio"/> Strict <input checked="" type="radio"/> Lenient	Security

**Save Changes and Reboot**

**MAC Address**      **00-50-DB-02-19-49**  
**Firmware Revision**      **3.0.13**

**Configure the MS/TP router**

Open Web browser to <http://192.168.1.18> (admin / Vimaster99)

**Note:** It is recommended to leave the default IP address of 192.168.1.18 The Wago gateway and MS/TP router need to be on the same IP subnet to communicate with each other.

In the "Configuration" tab you can modify the MS/TP (green) section to accommodate the BMS network requirements.

**WBM - IP Address and UDP Port (Optional)**

**Note:** It is recommended to not change the IP addresses for the Wago gateway and the MS/TP router as they both need to be on the same IP subnet to communicate.

Open web browser to <https://192.168.1.17/wbm> (admin / wago) Navigate to Configuration / Networking / TCP/IP Configuration

Change the IP address, hit Submit button (IP changes immediately, change URL)

Optional:

- Configuration / Users - Change passwords for wbm login
- Configuration / Networking / Routing - (Default) Gateway Address
- Fieldbus / BACnet / Configuration - BACnet UDP Port

**Quick Start Guide WAGO BACnet/IP with MS/TP Router** *(continued)*

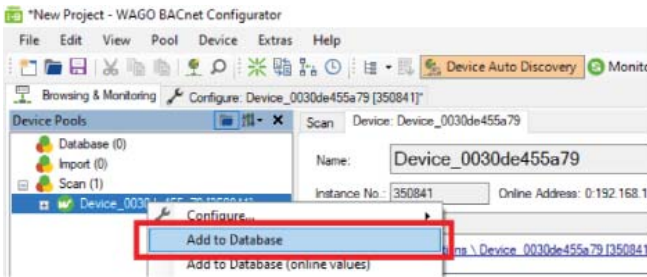

WAGO BACnet Configurator - Set BACnet Device ID (Optional)

**Note:** download the tool from the link on the left.

1. Scan the network for BACnet devices
2. Right click on the WAGO Gateway, and select "Add to Database"

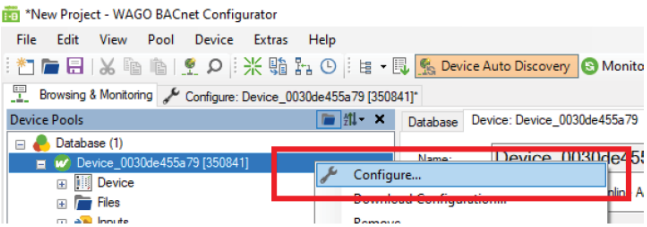

3. Switch to the "Database" tab, right click on the device and select "Configure"

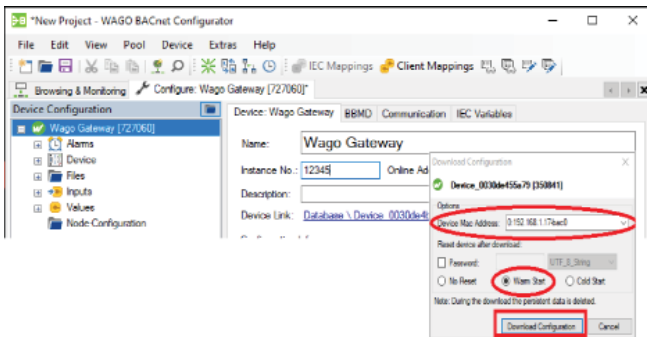

4. Change the "Device Instance No" and "Name", then "Store and Download"

## Process Overview

Step		Responsibility	Page
1	Install the module.	Contractor	6
2	Establish the CAN bus connection.	Contractor	12
3	Connect the plug-in attachment.	Contractor	14
4	Establish the connection to the BACnet.	IT expert/system integrator	15
5	Power supply	Electrician	17
6	Commission the gateway.	IT expert/system integrator	18

## Installing the Module

### IMPORTANT

Incorrect ambient conditions and installation locations may impair data transfer and cause damage to the gateway.

Ambient conditions during operation

- Permissible ambient temperature:  
32 to 102°F (0 to 40°C)
- Permissible relative humidity:
  - 32 to 102°F (0 to 39°C): ≤ 95%
  - ≥ 104°F (40°C): ≤ 50%
- No direct sunlight

### IMPORTANT

Operation by unauthorized persons may result in damage to the system. Access to the gateway must only be possible for authorized specialists with a key or tool.

#### Overview of connecting cables

Connecting cables	Length
<b>Accessories:</b> CAN bus cable	23 ft. (7 m)

# Connections and Operating Elements

## WAGO BACnet/IP gateway

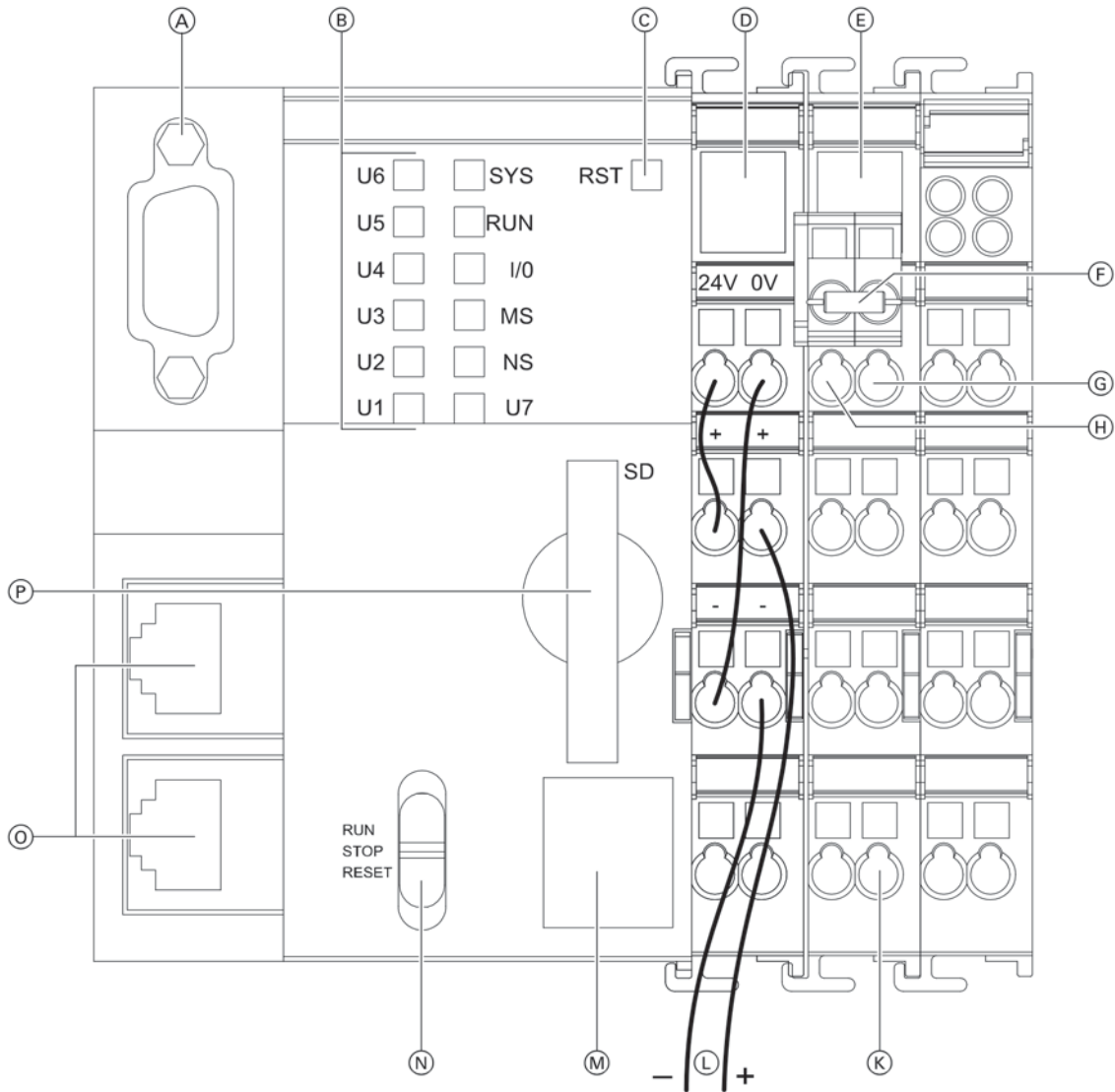

**Legend**

- (A) Serial interface
- (B) LED status indicators
- (C) Reset button RST
- (D) Status LED for supply voltage
- (E) Status LED for CAN bus interface
- (F) Plug-in attachment with terminator: See page 14
- (G) CAN low, for looping through the CAN bus
- (H) CAN high, for looping through the CAN bus
- (K) CAN bus shield
- (L) 24VDC supply voltage connection
- (M) Do not open!
- (N) Operating mode switch  
 RUN Standard mode  
 Factory setting: Do not adjust!  
 STOP Only for update process;  
 see WAGO commissioning manual.  
 RESET Do not adjust!
- (O) Service interface: LAN connection for connection to PC/laptop or BACnet/IP connection
- (P) Memory card slot

**Connections and Operating Elements** *(continued)*

**LED indicators**

LED	Status	Meaning	Measure
User LED U1	Green	The connection to the boiler is active.	--
	Red	The CAN bus interface has the status "Bus Off": Short circuit or other serious fault	<ul style="list-style-type: none"> <li>■ Check CAN bus connection: Plug, cable, terminator</li> <li>■ Check whether boiler is switched on.</li> <li>■ Check installation and connections of gateway and power supply unit.</li> <li>■ If the fault cannot be rectified, contact Viessmann Technical Service.</li> </ul>
	Other	Fault	Contact Viessmann Technical Service.

**Power supply unit**

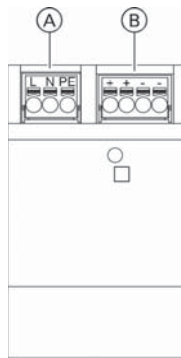

**Legend**

- Ⓐ INPUT 120VAC, 60 Hz
- Ⓑ OUTPUT 24VDC, 1.3A

## Connecting and Releasing Cores

### Gateway

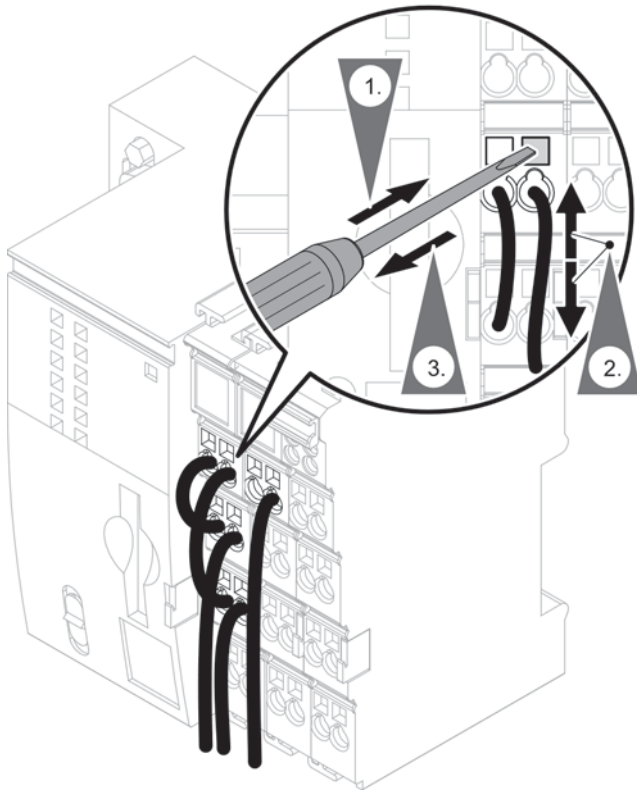

1. Insert a small flat head screwdriver into the opening directly above the wire..
2. Tilt the handle of the screwdriver up.
3. Pull the wire straight out.

Example: BACnet/IP gateway

### Power supply unit

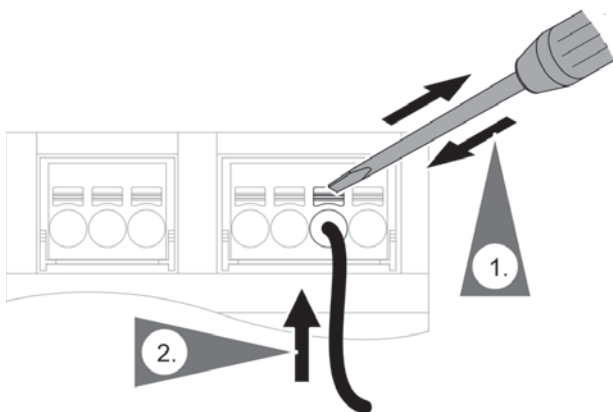

1. Using a small screwdriver push in the orange button directly above the wire.
2. Pull the wire straight out.

## Establishing the CAN Bus Connection

- The Viessmann CAN bus is designed for “line” bus topology with a terminator at both ends (accessories).
- With CAN bus, the transmission quality and the cable lengths depend on the electrical properties of the cable:
  - Only use cable types listed in the following table.
  - Only use one cable type within a CAN bus.

**Recommended cable type (on site):**

<b>CAN bus cable</b>	In line with ISO 11898-2, twisted pair cable, shielded
■ <b>Cable cross-section</b>	0.34 to 0.6 mm <sup>2</sup> (22 to 18 AWG)
■ <b>Characteristic impedance</b>	95 to 140 Ω
■ <b>Max. length</b>	650 ft. (200 m)

**Alternative cable types (on site):**

<b>CAN bus cable</b>	2-core, CAT5, shielded
■ <b>Max. length</b>	165 ft. (50 m)
<b>CAN bus cable</b>	2-core, CAT7, shielded
■ <b>Max. length</b>	650 ft. (200 m)



**Establishing the CAN Bus Connection** *(continued)*

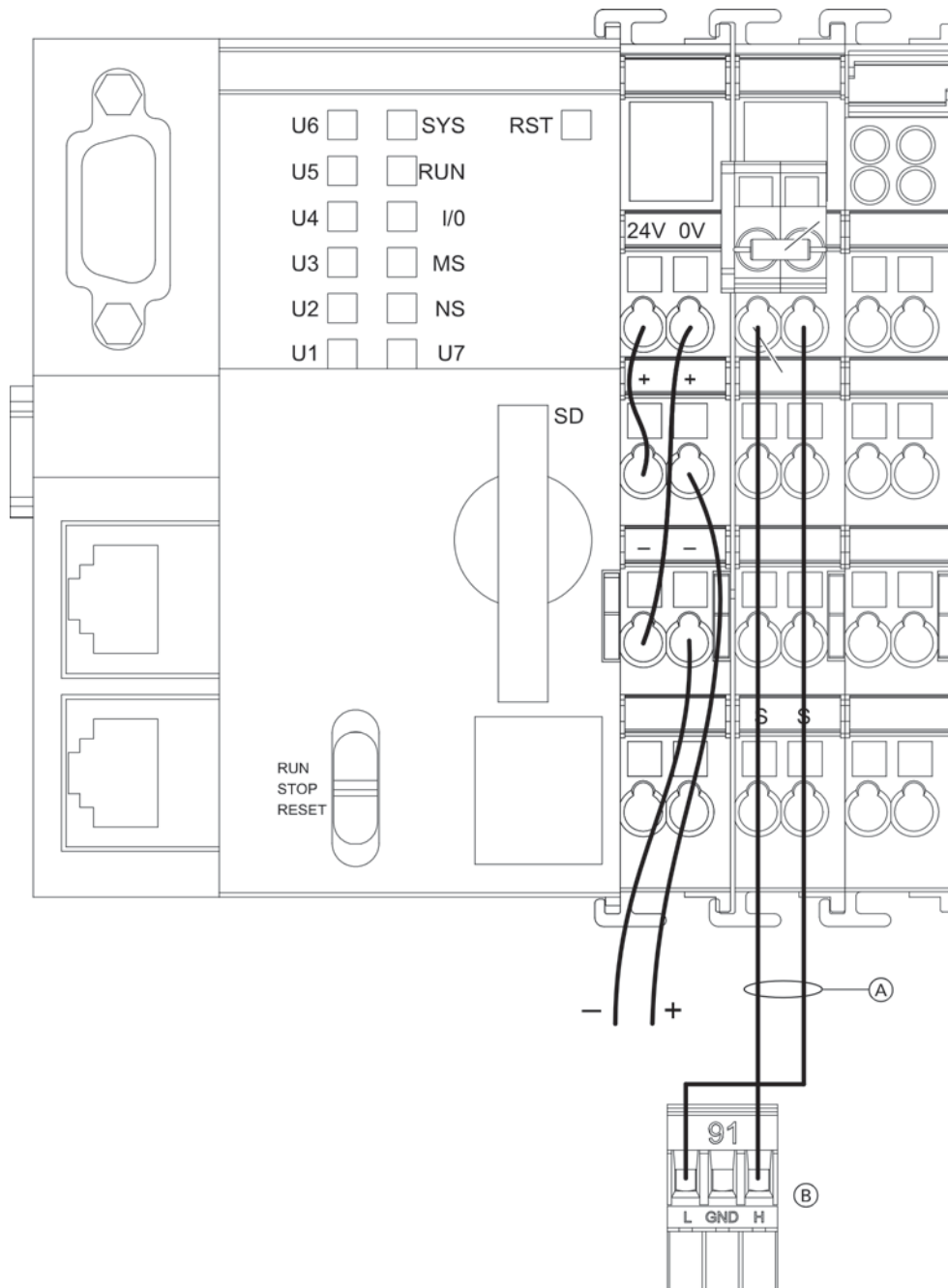

**Legend**

- (A) CAN bus shield
- (B) Cable for 91 for controlling the boiler  
(standard delivery of the gateway)

 Installation and service instructions for boiler control unit

## Connecting the Plug-in Attachment

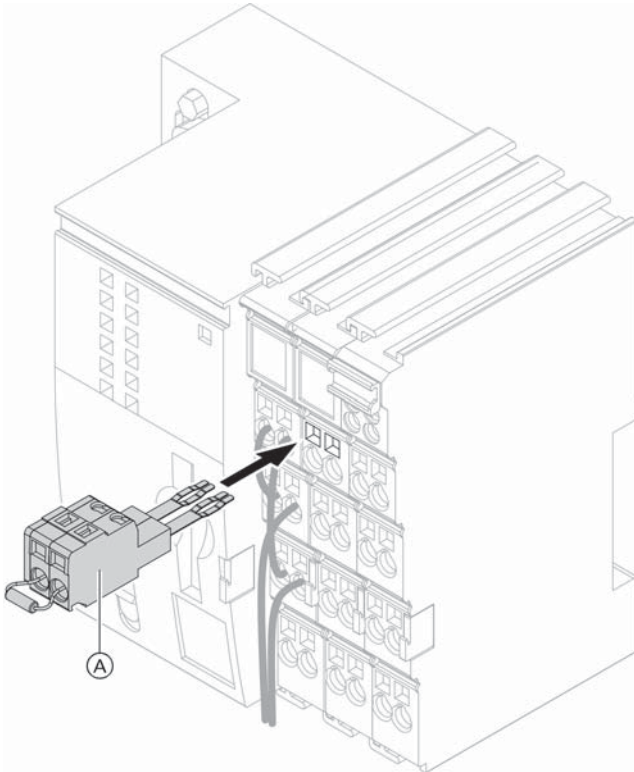

### WAGO BACnet/IP gateway

The plug-in attachment (standard delivery) must be plugged in.

Do not connect the plug-in attachment until the CAN bus cable has been connected.

If the gateway is at the beginning or end of the CAN bus:

### Legend

Ⓐ Plug-in attachment with terminator (standard delivery)

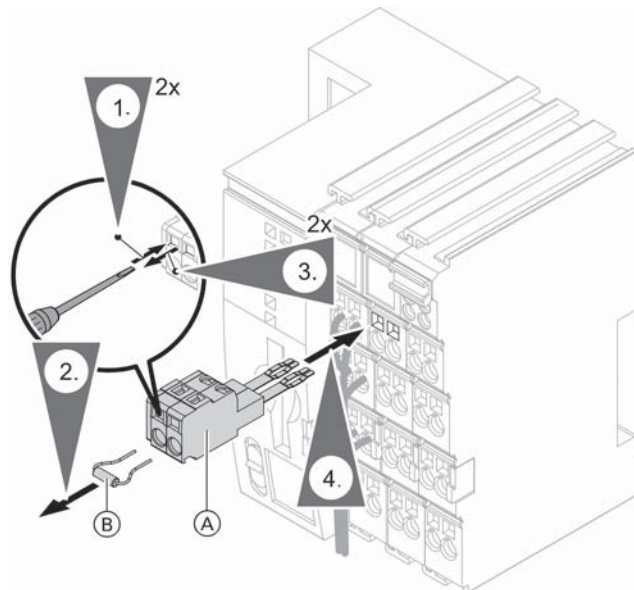

### If the gateway is not at the beginning or end of the CAN bus:

Plug in the plug-in attachment without the terminator. Use the plug-in attachment for looping through the CAN bus.

### Legend

Ⓐ Plug-in attachment (standard delivery)

Ⓑ Terminator

# Establishing the Connection to the BACnet/IP Gateway

The connection to the network must be established by the system integrator.

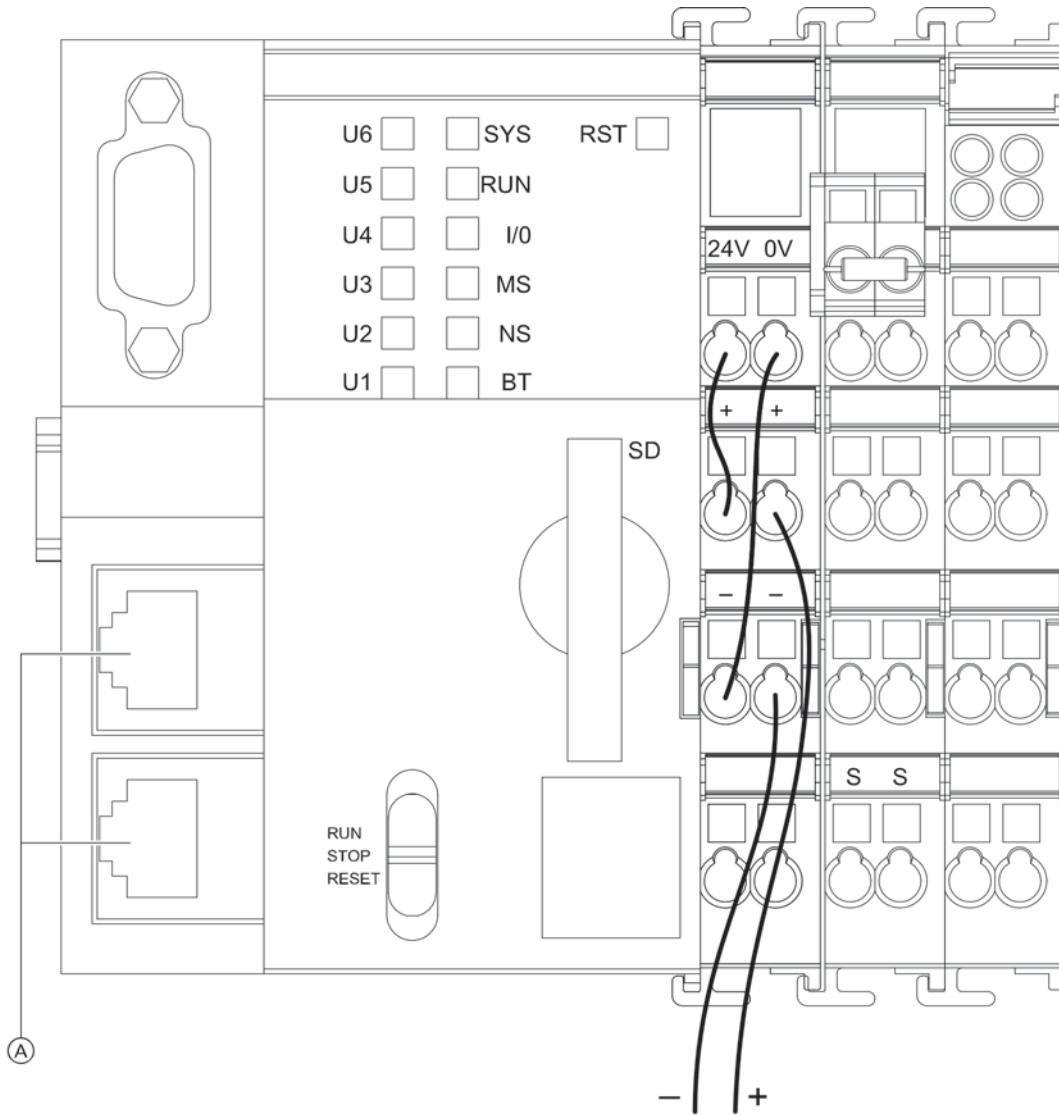

**Legend**

Ⓐ Connect BACnet/IP via RJ45 interface

# Connecting the Gateway to the Power Supply Unit

Connecting cores in the power supply unit.

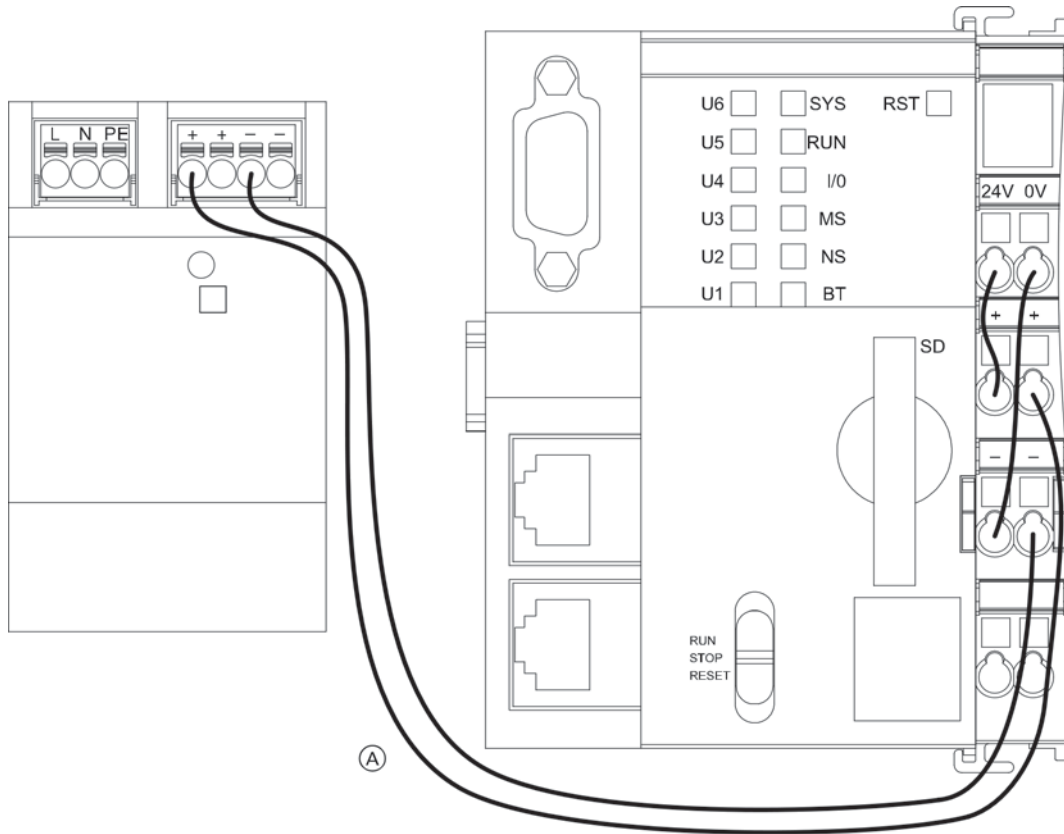

**Legend**

Ⓐ Cable cores between gateway and power supply unit (standard delivery)

The WAGO gateway is supplied in the enclosure with the power supply unit prewired to the gateway.

## Power Supply

### General information

The WAGO gateway comes complete with a 6 ft. (2 m) power cord with convience plug for simplified installation.



### WARNING

The control must be grounded.  
Ensure that 'L', 'N' and 'G' are not interchanged.



### WARNING

Incorrectly executed electrical installations can lead to injuries from electrical current and result in appliance damage.

### IMPORTANT

Electrical installations must comply with the latest edition of:

- In the U.S.A., the National Electrical Code (NEC), ANSI/NFPA 70 and any other state, local codes and/or regulations.
- In Canada, the Canadian Electrical Code (CEC), CSA C22.1 Part 1 and any other province, territory, local codes and/or regulations.

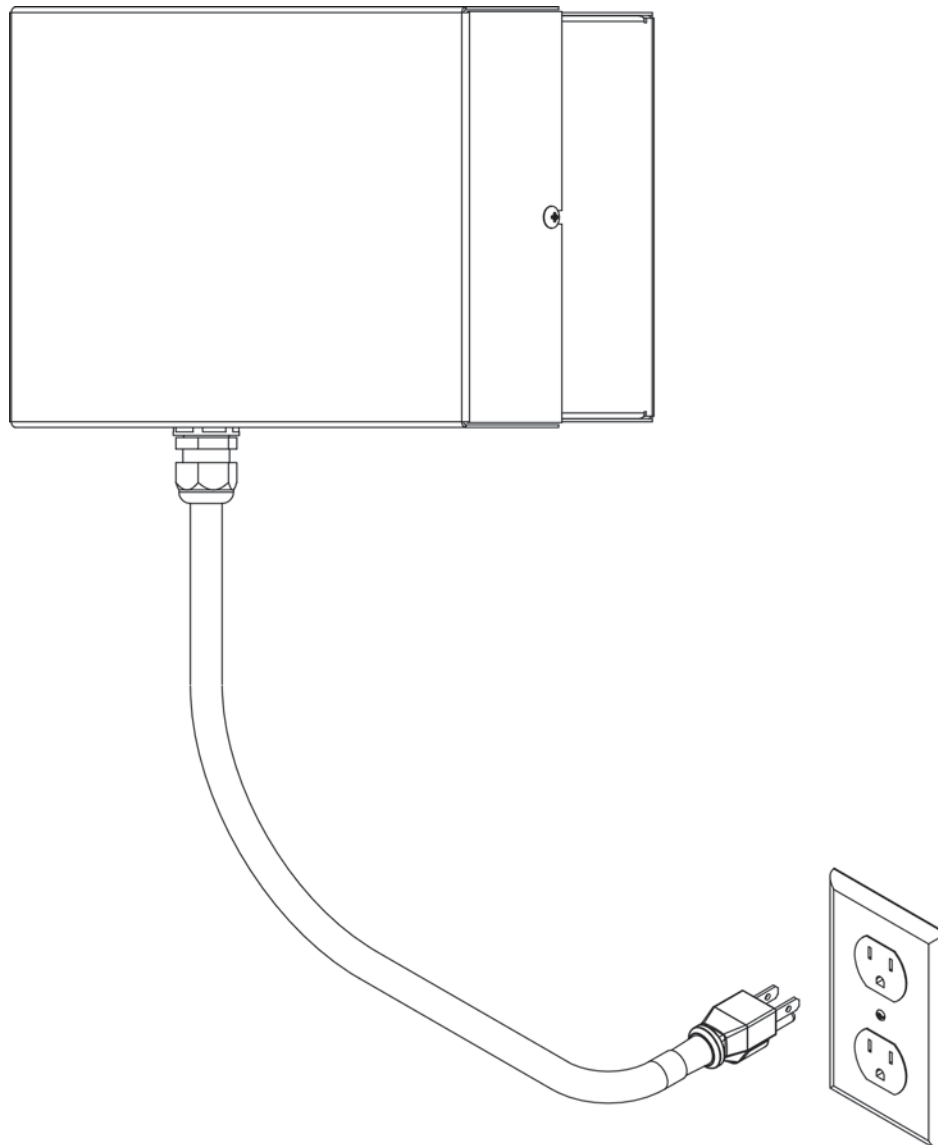

## Commissioning the Gateway

### WAGO BACnet configuration

- set BACnet device ID (optional)

**Note:** download the tool from the link below.



Commissioning must be carried out by the IT expert or system integrator.

1. Switch on the boiler.
2. Switch on the power supply for the gateway.
3. Check the status of the LED for standard mode after switching on: See the following table. If the LED indicators do not match the table, check the connections: See overview on page 8.

LED indicators	Status of the LED for standard mode
SYS	Green
RUN	Green
I/O	Green
MS	OFF
NS	OFF
U1	Green
U2 - U6	Off
BT	Green <b>Note:</b> If the LED lights up red or yellow, a BACnet-specific error is present. Clarification with system integrator is required

4. Scan the network for BACnet devices. Right click on the WAGO Gateway, and select "Add to Database"

## Dismounting the Terminals

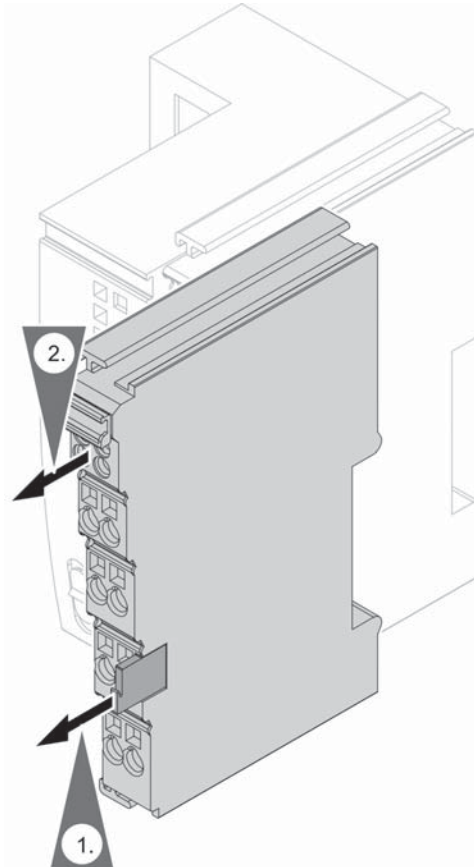

If the gateway or power supply unit need to be dismantled, e.g. because the device is faulty, proceed as shown in the following diagrams.

## Dismounting the Gateway

### Dismounting the controller

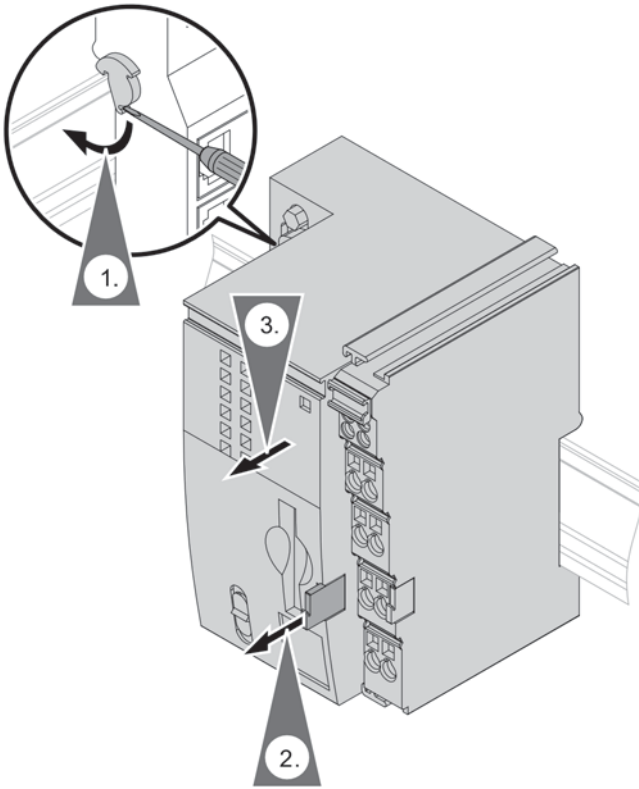

### Dismounting the Power Supply Unit

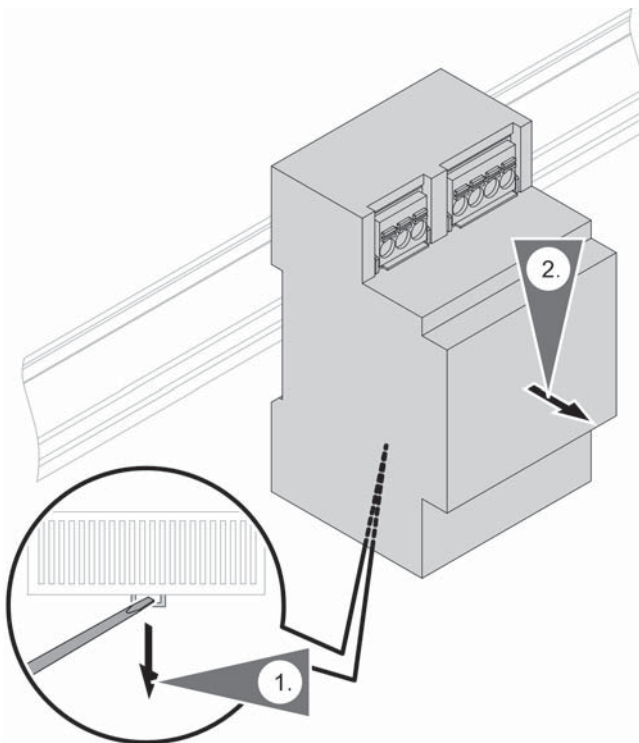

## Gateway

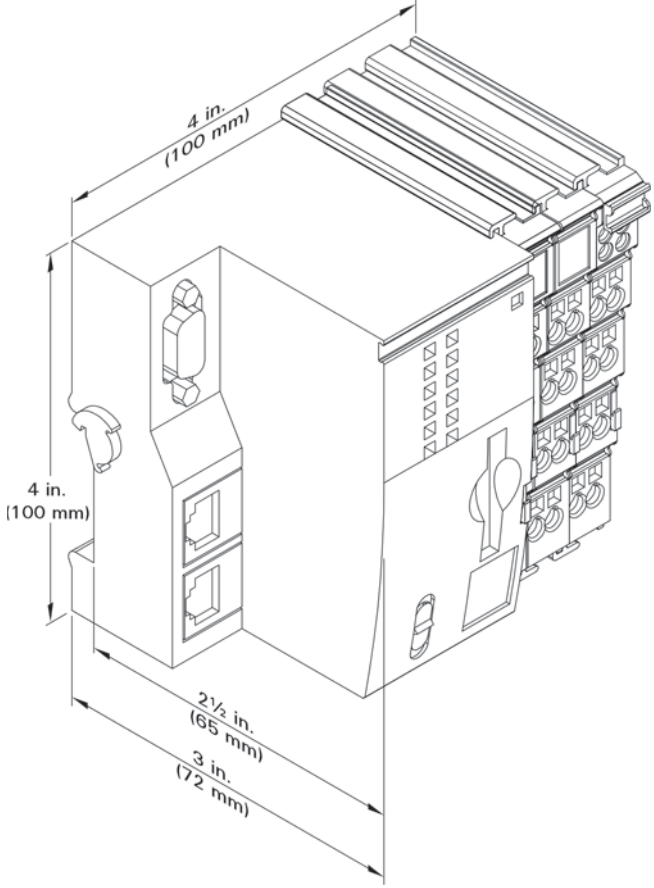
<b>WAGO BACnet/IP gateway</b>	
Power supply	24VDC
Power consumption	Max. 116 mA
Nominal rating	2.8 W
Permissible ambient temperature <ul style="list-style-type: none"> <li>■ Operation</li> <li>■ Storage</li> <li>■ Transport</li> </ul>	32 to 104°F (0 to 40°C) -4 to 140°F (-20 to +60°C) -4 to 140°F (-20 to +60°C) for max. 3 months or average 95°F (35°C)
Dimensions	 <p>The diagram shows an isometric view of the WAGO BACnet/IP gateway. It is a rectangular device with a depth of 4 inches (100 mm) and a height of 4 inches (100 mm). The front panel features a handle on the left side, a power switch, and two RJ45 ports. The right side of the device has a terminal block with multiple screw terminals. The width of the device is indicated as 2 1/2 inches (65 mm) and 3 inches (72 mm).</p>



## Power Supply

### Power supply unit

Rated voltage	100 to 240V ~
Rated frequency	50 to 60 Hz
Rated current	1.34A
Output voltage	24VDC
Permissible ambient temperature	
■ Operation	32 to 104°F (0 to 40°C)
■ Storage and transport	-40 to 185°F (-40 to +85°C)
Dimensions	<p>The diagram shows an isometric view of a rectangular power supply unit. It features a top-mounted terminal block with two rows of terminals. The dimensions are as follows:</p> <ul style="list-style-type: none"> <li>Top width: 2 1/4 in. (54 mm)</li> <li>Height: 3 1/8 in. (90 mm)</li> <li>Front width: 2 in. (52.5 mm)</li> <li>Depth: 2 1/4 in. (56 mm)</li> </ul>

## BACnet/IP to MS/TP Router Specification



To provide a BACnet MS/TP interface to the Viessmann Automation Gateway BACnet/IP.

The router routes messages between BACnet/IP and BACnet MS/TP networks as per the ANSI/ASHRAE 135 (ISO 16484-5) standard. It allows BACnet MS/TP devices connected over RS485 to communicate with the Automation Gateway which is BACnet/IP only. The router is configurable via its web page.

Default IP: 192.168.1.18

User: admin

Pass: Vimaster99

Device: Contemporary Controls BASRouter

Complete User guide can be found at

<https://www.ccontrols.com/basautomation/basrouter.php>

### Features and Benefits

- Route between BACnet®/IP to BACnet® MS/TP networks
- Diagnostic LEDs include MS/TP traffic monitor
- Optically isolated MS/TP communication port
- Web server for commissioning, reconfiguring and troubleshooting
- 10/100 Mbps Ethernet auto-negotiation and automatic medium-dependent interface crossover port

### Product Specifications

#### Power

Input-----	DC
Voltage-----	24 (± 10%)
Power Consumption-----	2 W
Input-----	AC
Voltage-----	24 (± 10%) (47-63 Hz)
Power Consumption-----	4 VA

#### Environmental

Operating Temperature-----	-40°C to 75°C; -40°F to 167°F
Storage Temperature-----	-40°C to 85°C; -40°F to 185°F
Relative Humidity-----	10-95%, non-condensing

#### Enclosure

Material-----	Metal (Black)
Dimensions (W x H x D)-----	2.76" x 4.85" x 1.00"
-----	(70 mm x 123 mm x 26 mm)
Installation -----	TS-35 DIN Rail

#### Ethernet Port

Compliance-----	IEEE 802.3
Data Rate-----	10 Mbps, 100 Mbps
Physical Layer-----	10BASE-T, 100BASE-TX
Max Cable Length-----	100 m
Port Connector-----	Shielded RJ-45
LED Indicators-----	Green = 100 Mbps (flash for activity)
-----	Yellow = 10 Mbps (flash for activity)

#### MS/TP Port

Compliance-----	ANSI/ASHRAE 135 (ISO 16484-5)
Data Rate-----	9,600; 16,200; 38,400; 76,800 bps
Physical Layer-----	EIA-485
Max Cable Length-----	1200 m
Port Connector-----	3-pin terminal block
-----	Jumper-selectable bias and termination
LED Indicators-----	Green = MS/TP (flash for activity)

#### Regulatory Compliance

FCC-----	Part 15 Class A
UL-----	508
CSA---	C22.2 No. 142-M1987: Industrial Control Equipment

**BACnet/IP to MS/TP Router Specification** *(continued)*

**Dimensions**

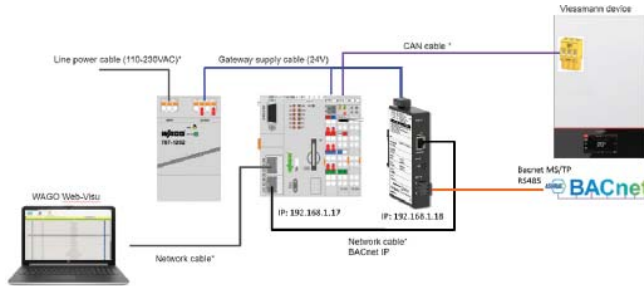
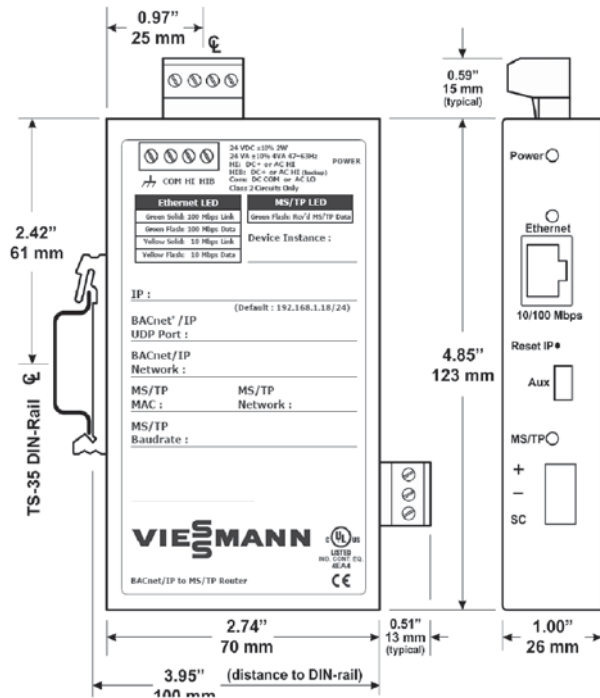

After successfully logging in, the main - Router Configuration web page is loaded. This page allows for setting up router parameters.

**Reset IP Switch**

The Reset IP switch is located on the front, underneath RJ-45 connector. To reset the router to its default values (except for configuration settings), press and hold the Reset IP button using a paper clip for at least 3 seconds while the router is powered. Remove power and restore power again to complete the reset IP, User ID, and Password procedure to factory-programmed default values as shown below. Default User Name is admin and default Password is admin.

**Webpage Configuration**

The BASrouter contains an interactive web server accessible from any Internet-compatible PC on the local network with recent versions of most standard web browsers such as Microsoft Internet Explorer, Microsoft Edge, Mozilla Firefox, or Google Chrome installed. It is factory-programmed with a default fixed IP address of 192.168.1.18 and a Class C subnet mask of 255.255.255.0 (/24). The default login credentials for the web page are admin / Vimaster99.

The figure shows the setup for initial network configuration. Using BASRT-B, a computer for configuration, and a connection to the MS/TP network.

To configure the router, connect it to a computer with an Ethernet cable and use a standard web browser.

For initial configuration, the PC chosen for the procedure should temporarily have its IP address modified to match the default subnet of the BASrouter and Wago gateway.

**BACnet/IP to MS/TP Router Specification** *(continued)*

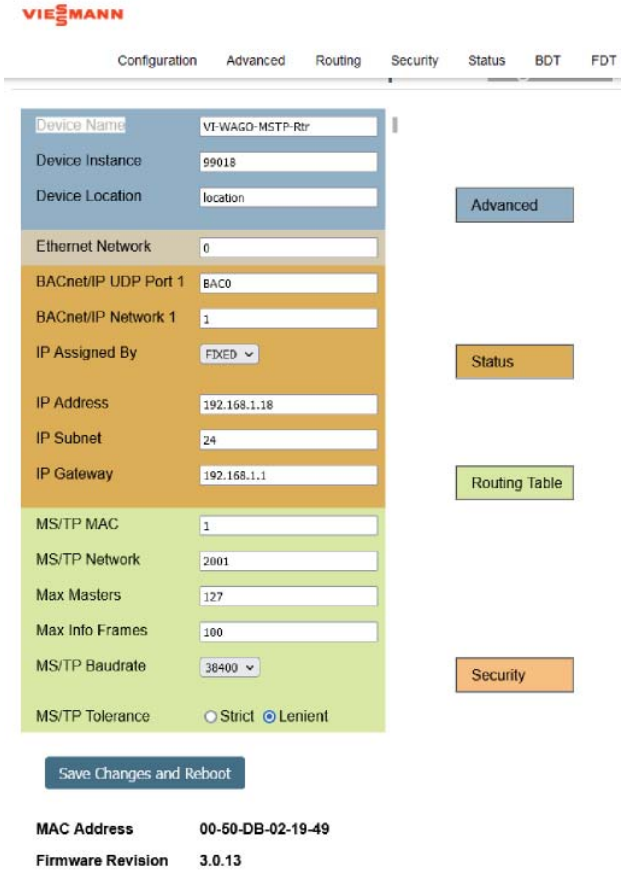

**Web page navigation**

The BASrouter has a navigation bar at the top of the web page which can be used to navigate through all its configuration, advanced settings, status, bdt and fdt tables, and security tabs.

In addition, a dedicated button for each configuration item is placed on the main web page adjacent to the configuration fields:

When the Save Changes button is clicked, the parameters are stored to non-volatile memory, the unit will automatically reboot (in a few seconds) and the changes will take effect. Advanced, Status and Security screens used to access status and more configuration.

**Device Parameters**

**Device Name**

The BASrouter’s Device Object Name can be configured in this field. It is required to be unique throughout the BACnet network. It can be up to 20 characters.

**Device Instance (Default Value = 99018)**

The router’s device instance is a 22-bit value (0–4,194,302). Do not use 4,194,303 which is reserved by BACnet. Each BACnet device within the same BACnet internetwork must have a unique device instance. One must be assigned to the BASRT-B.

Device Location (Default Value = location)

The Device Location can be configured in this field.

**BACnet Ethernet (0 disables BACnet Ethernet)**

Ethernet Network (Default Value = 0)

Leave at 0 to disable, not used for communication with Wago Automation Gateway

## BACnet/IP to MS/TP Router Specification *(continued)*

### BACnet/IP Parameters

#### BACnet/IP UDP Port (Default Value = 0xBAC0)

This 16-bit hex value (BAC0–BACF) is set to BAC0 by default. Usually, this default value should not be changed. In typical networks, each BACnet/IP device will use the same UDP port.

#### BACnet/IP Network (Default Value = 1)

Like all networks in the BACnet internetwork, the BACnet/IP network must have a unique number (1–65534). Do not use addresses 0 or 65535 since these addresses are reserved.

This value must NOT be the same as MS/TP network number.

#### IP Assigned By (Default Value = FIXED)

The default IP address of the BASrouter is FIXED but can be obtained automatically from a DHCP server or can be set to a FIXED (static) IP address.

#### IP Address (Default Value = 192.168.1.18)

The IP address of the router can be 1.0.0.1–223.255.255.254. A private address is usually assigned to the BASRT-B.

#### IP Subnet (Default Value = 24)

This value (0–31 in the “slash” notation) is the number of bits with a “1” in the mask. The default value of 24 corresponds to 255.255.255.0 in the dotted decimal format. All devices on the same subnet which communicate via BACnet/IP should use the same subnet mask.

#### IP Gateway (Default Value = 192.168.1.1)

The default gateway for the IP stack is a dotted decimal number in the range of 1.0.0.1–223.255.255.254. This will be the IP address of your local IP router — if one exists.

### MS/TP Parameters

#### MS/TP MAC (Default Value = 01)

This is the unique 8-bit (0–127) MAC address of the router’s MS/TP port, in decimal. Lower MAC address numbers are preferred with the default recommended. It is further recommended that all other BACnet devices attached to the same MS/TP network be assigned consecutive MAC addresses beginning with 1 without allowing any gaps in addressing. Slave devices may have MAC addresses of 128–254, but MAC address 255 is reserved.

#### MS/TP Network (Default Value = 2001)

This 16-bit decimal network number (1–65534) must be unique for all BACnet networks within the BACnet internetwork. No other networks, regardless of type, can have the same network number. Do not use addresses 0 or 65535 since these are reserved. Make sure the MS/TP network number does not match the BACnet/IP network number. They must be different.

#### Max Masters (Default Value = 127)

Only master nodes participate in the MS/TP token-passing process. The highest master MAC address (in decimal) in the MS/TP network is 127 and you should use 127 if you are unsure of other MS/TP device addresses. Each MS/TP device should use this same value. For a value in this field to be proper, it must equal or exceed the highest MAC address for any master on the network. Optimum performance occurs when this value: equals the highest MAC address of any master, and all masters use sequential MAC addresses starting with 1. Since many BACnet devices do not allow this parameter to be changed, leave the BASRT-B at the default value.

#### Max Info Frames (Default Value = 100)

This is the maximum number of messages that can be routed onto the MS/TP network by the router per token pass. Its range is 1–100, and typical values are 20–40. Smaller values provide less access to the MS/TP network from the BACnet/IP network because they give native MS/TP messages higher priority than those passed by the router from BACnet/IP. The default value usually provides good performance.

#### MS/TP Baud Rate (Default Value = 38400)

The baud rate of the MS/TP network can be 9600, 19200, 38400 or 76800 bps. All MS/TP devices on the same MS/TP network must use the same baud rate. On power up, as the router polls for other masters, autobauding devices adjust to its baud rate.

#### MS/TP Tolerance (Default Selection = Strict)

This setting determines the degree to which interoperability with devices is successful. The Lenient option is less efficient for traffic flow but optimizes interoperability. When using Lenient the BASrouter will wait longer for devices to respond to a poll for master request. A slight improvement in performance will be realized by selecting the Strict setting.

## Final Decommissioning and Disposal

Viessmann products can be recycled. Components and substances from the system are not part of ordinary household waste.

For decommissioning the system, isolate the system from the power supply and allow components to cool down where appropriate.

All components must be disposed of correctly.



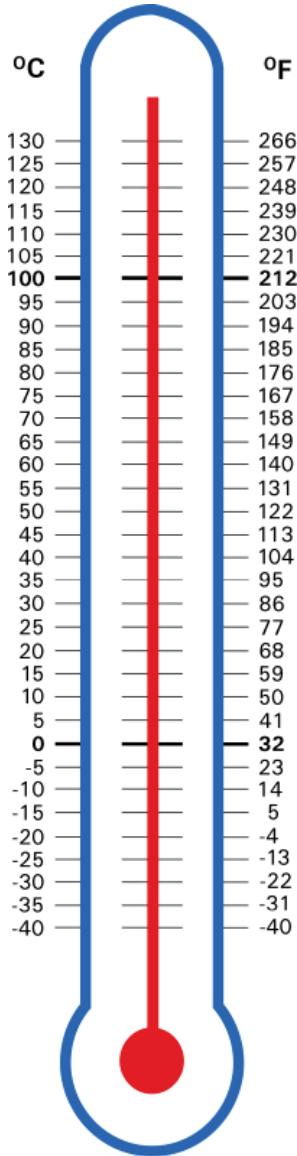

Printed on environmentally friendly  
(recycled and recyclable) paper.



Technical information subject to change without notice.

Viessmann Manufacturing Company Inc.  
750 McMurray Road  
Waterloo, Ontario • N2V 2G5 • Canada  
**TechInfo Line 1-888-484-8643**  
1-800-387-7373 • Fax (519) 885-0887  
www.viessmann.ca • info@viessmann.ca

Viessmann Manufacturing Company (U.S.) Inc.  
45 Access Road  
Warwick, Rhode Island • 02886 • USA  
**TechInfo Line 1-844-649-5886**  
1-800-288-0667 • Fax (401) 732-0590  
www.viessmann-us.com • info@viessmann-us.com