

Installation Instructions

for use by heating contractor

VIESSMANN

Replacement Radial Fan Assembly, Part No. 7373 112

Please file in Service Binder

for Vitodens 100 boilers

Safety and Installation Requirements

Please ensure that these instructions are read and understood before commencing installation. Failure to comply with the instructions listed below can cause **product/property damage, severe personal injury, and/or loss of life.**

Working on the equipment

The installation, adjustment, service, and maintenance of this product must be done by a **licensed professional heating contractor** who is qualified and experienced in the installation, service, and maintenance of hot water boilers. There are no user serviceable parts on the boiler, burner, or control.

Ensure **main power** supply to equipment, the heating system, and all external controls has been **deactivated**. **Close main gas supply valve.** Take precautions in both instances to avoid accidental activation of power during service work.



Ensure that the installation literature of other applicable components is referenced.

Enclosure Removal

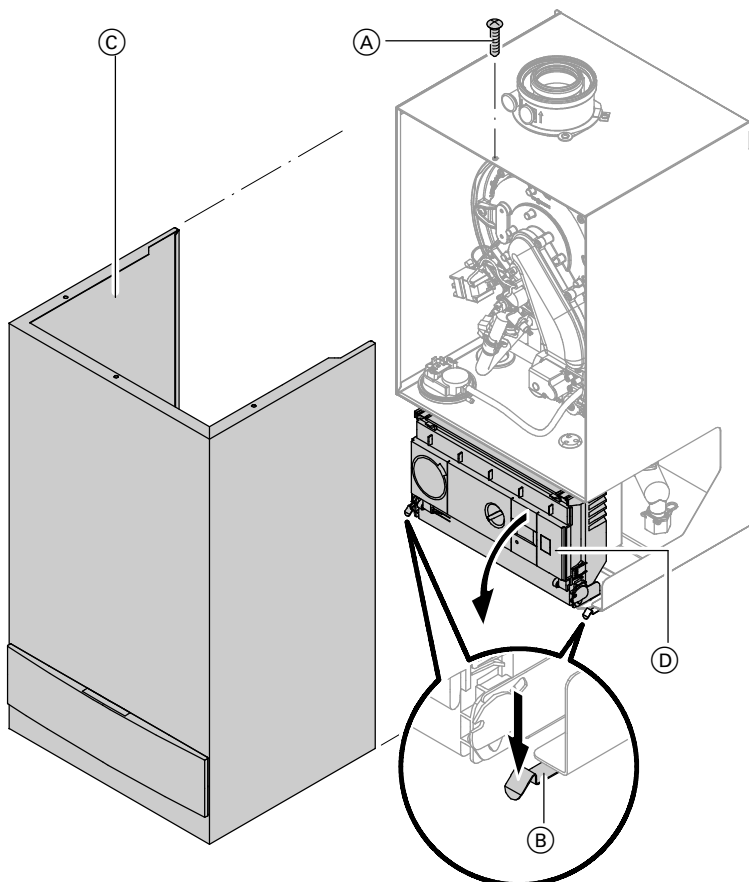

1. Remove the screw at the top of boiler (A).
2. Press down on springs at bottom of boiler (B) and remove the front enclosure panel (C).
3. Flip control console down (D).
4. Shut off the secondary side of the boiler and isolate the boiler from the system.

Note:

The boiler is still filled with water.

Burner Removal

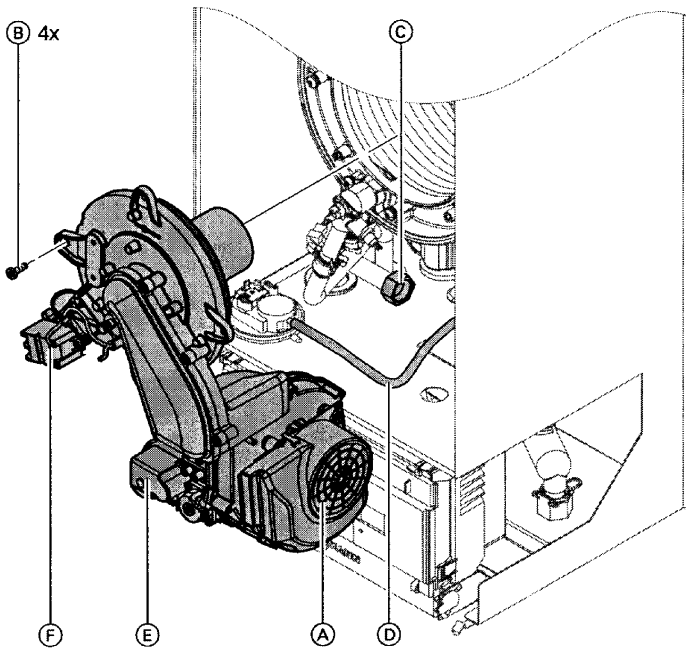

5. Disconnect electrical cables from gas valve (E), and ignition transformer unit (F).
6. Remove connection hose (D) from air pressure switch.
7. Loosen the fitting (C) on the gas connection pipe.
8. Loosen four screws (B), remove burner and disconnect all electrical cables from blower motor (A).

CAUTION

To avoid damage to the burner, do not lay burner on its cylindrical burner tube. Failure to heed this caution may cause damage to the burner tube, which may lead to improper operation.

Fan Replacement

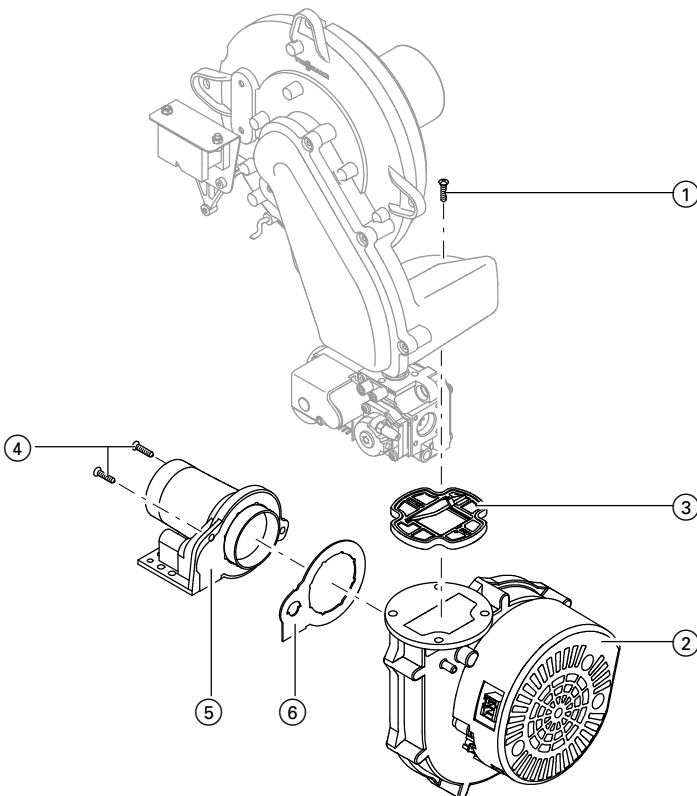

9. Release two screws (1), remove fan (2) and mixture flapper (3) from the mixing channel.
10. Release two screws (4) and remove venturi assembly (5) from fan (2).
11. Fit venturi assembly (5) with new gasket (6) to new fan (2).
NOTE: Replacement screws (4) are self tapping.
Tightening screw torque: 44.3 inch-pounds (5 Nm).
12. Fit fan (2) with mixture flapper (3) to the mixing channel.
Tightening screw torque: 44.3 inch-pounds (5 Nm).

IMPORTANT

Ensure that mixture flapper (3) is correctly positioned. Check mixture flapper (3) for free movement (opens up in the direction of the air flow).

For tightening, use a calibrated torque wrench.



Installation and Service
Instructions Vitodens 100

5352 108 v1.1

Reinstall Burner

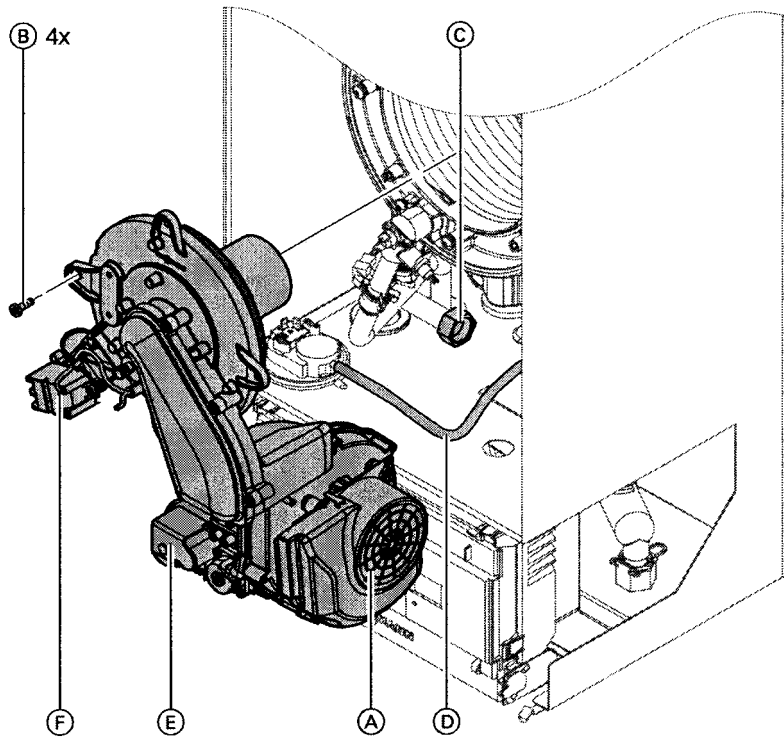

13. Replace electrical cables from fan motor (A), mount burner, and diagonally tighten 4 torque screws (B) (approx. 35.4 inch-pounds (4 Nm) using a calibrated torque wrench).
14. Insert new gasket and tighten the fitting (C) on the gas connection pipe.
15. Insert air pressure switch connection pipe (D) onto the gas valve "OUT" connector (P2 on the switch).
16. Replace electrical cables from gas valve (E), and ignition transformer unit (F).

IMPORTANT

Insert new gaskets on all gas connections.

17. Check the gas connections for leaks.
18. Open gas shutoff valve and switch on power supply.

Viessmann Manufacturing Company (U.S.) Inc.
45 Access Road
Warwick, Rhode Island • 02886 • USA
1-800-288-0667 • Fax (401) 732-0590
www.viessmann-us.com • info@viessmann-us.com

Viessmann Manufacturing Company Inc.
750 McMurray Road
Waterloo, Ontario • N2V 2G5 • Canada
1-800-387-7373 • Fax (519) 885-0887
www.viessmann.ca • info@viessmann.ca

5352 108 v1.1

Technical information subject to change without notice.



Printed on environmentally friendly
(recycled and recyclable) paper.