

Technical Data Manual

Model Nos. and pricing: see Price List



DLFSFBH

Models 12XAK

Floor Console Ductless System

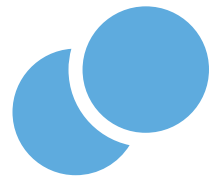

VITOCAL IND-F



Product may not be exactly as shown

LOW SOUND LEVELS

When noise is a concern, the ductless systems are the answer. The indoor units are whisper quiet. There are no compressors indoors, either in the conditioned space or directly over it, and there is none of the noise usually generated by air being forced through ductwork.

SECURE OPERATION

If security is an issue, outdoor and indoor units are connected only by refrigerant piping and wiring to prevent intruders from crawling through ductwork. In addition, since outdoor units can be installed close to an outside wall, coils are protected from vandals and severe weather.

SIMPLE SERVICING AND MAINTENANCE

Removing the top panel on the outdoor units provides immediate access to the control compartment, providing a service technician access to check the unit's operation. In addition, the draw-thru design of the outdoor section means that dirt accumulates on the outside surface of the coil. Coils can be cleaned quickly from the inside using a pressure hose and detergent.

On all indoor units, service and maintenance expense is reduced due to easy-to-use cleanable filters. In addition, these console systems have extensive self-diagnostics to assist in troubleshooting.

BUILT-IN RELIABILITY

Ductless system indoor and outdoor units are designed to provide years of trouble-free operation. The console indoor units include protection against freeze-up and high evaporator temperatures on heat pumps. The condensing units on heat pumps are protected by a three minute time delay before the compressor starts the over-current protection and the high temperature protection.

INDIVIDUAL ROOM COMFORT

Maximum comfort is provided because each space can be controlled individually based on usage pattern. The air sweep feature provided permits optimal room air mixing to eliminate hot and cold spots for occupant comfort. In addition, year-round comfort can be provided with heat pumps.

ECONOMICAL OPERATION

The ductless system design allows individual room heating or cooling when required. There is no need to run large supply-air fans or chilled water pumps to handle a few spaces with unique load patterns. In addition, because air is moved only in the space required, no energy is wasted moving air through ducts.

EASY-TO-USE CONTROLS

The console units have microprocessor-based controls to provide the ultimate in comfort and efficiency. The user friendly wireless remote control provides the interface between user and the unit.

ACCESSORIES

Customizing these ductless systems to your application is easily accomplished. Adding a condensate pump accessory to the console fan coil provides installation flexibility.

OPTIONAL WIRED CONTROLLER

AGENCY LISTINGS

All systems are listed with AHRI (Air Conditioning, Heating & Refrigeration Institute), and ETL.

MODEL NUMBER NOMENCLATURE

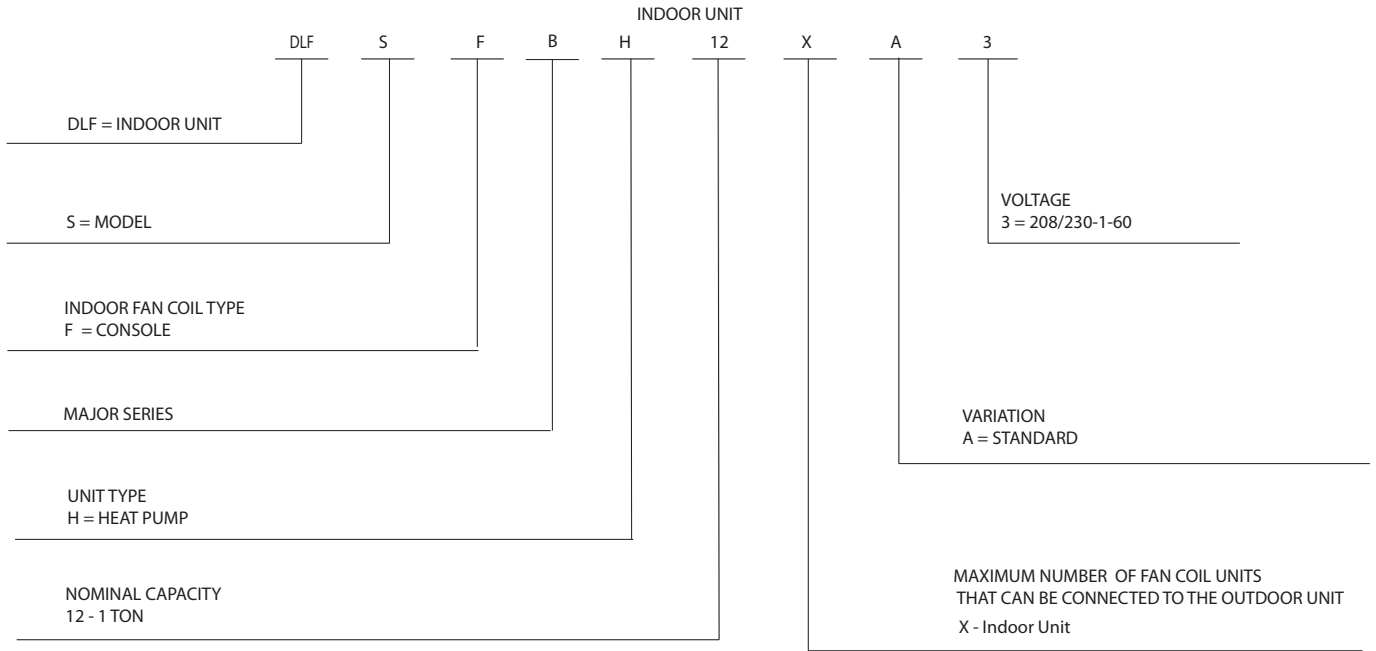

A230160



Use of the AHRI Certified TM Mark indicates a manufacturer's participation in the program. For verification of certification for individual products, go to www.ahridirectory.org.

A230164

STANDARD FEATURES AND ACCESSORIES

Ease Of Installation	
Mounting Brackets	S
Low Voltage Controls	S
Floor Mounting Installation	S
Ceiling Installation	S
Comfort Features	
Microprocessor Controls	S
Wired Remote Control	A
Wireless Remote Control	S
Wi-Fi Remote Control (Dongle Only with Built-In USB)	A
Automatic Up-Down Air Sweep	S
Air Direction Control	S
Auto Restart Function	S
Cold Blow Protection On Heat Pumps	S
Freeze Protection Mode On Heat Pumps	S
Turbo Mode	S
Silence Mode	S
Auto Changeover On Heat Pumps	S
Follow Me	S
Energy Saving Features	
Sleep Mode	S
Stop/Start Timer	S
46° F Heating Mode (Heating Setback)	S
Safety And Reliability	
Indoor Coil Freeze Protection	S
Aluminum Golden Hydrophilic pre-coated fins	S
Indoor Coil High Temp Protection in Heating Mode	S
Ease Of Service And Maintenance	
Cleanable Filters	S
Diagnostics	S
Liquid Line Pressure Taps	S
Application Flexibility	
Condensate Pumps	A

Accessories

MODEL NO.	DESCRIPTION	FOR MODELS
KSACN0901AAA	7-Day Programmable Remote Controller	All Sizes
KSACN0101AAA	Wired Remote Controller	All Sizes
KSAIF0601AAA	Wi-Fi Kit (Dongle Only with Built-In USB)	All Sizes

Legend

S - Standard

A - Accessory

DIMENSIONS AND CLEARANCES

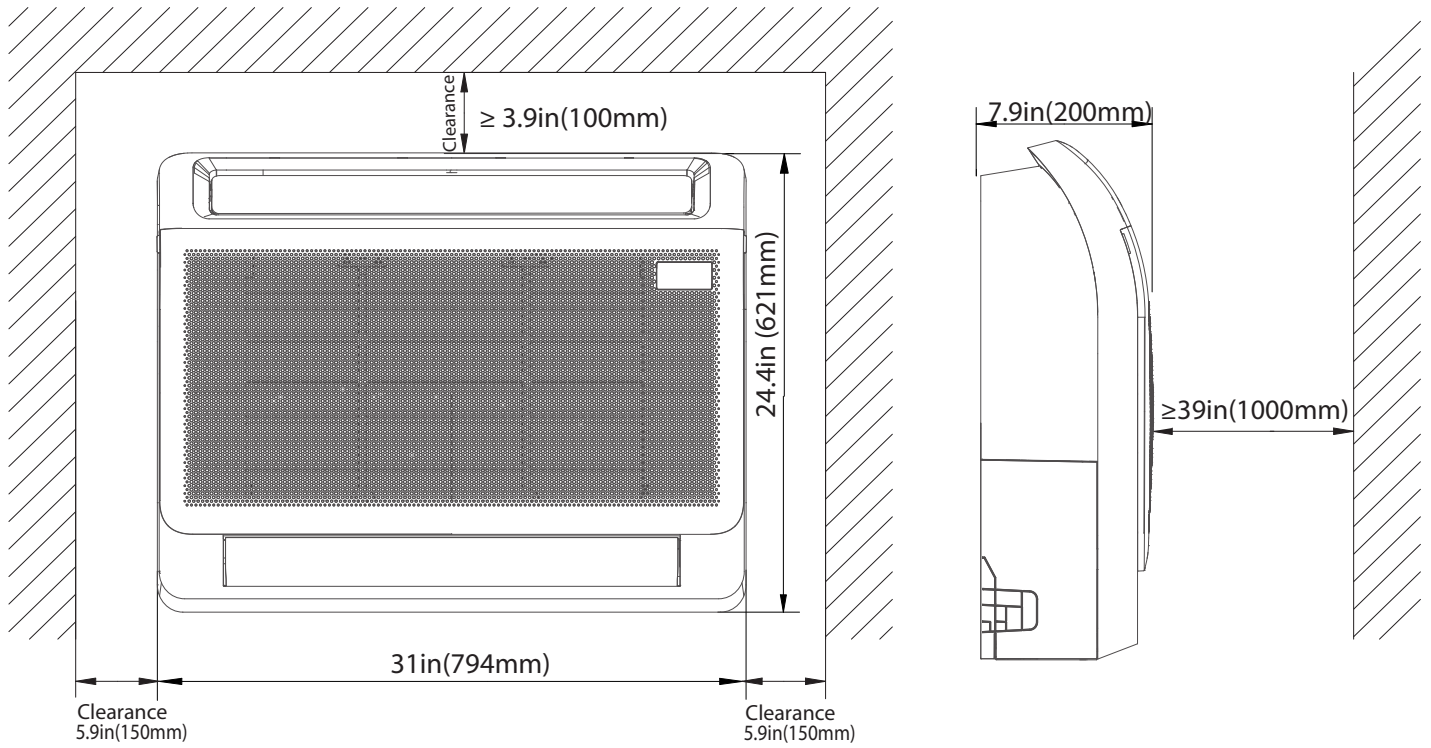

Fig. 2 — Dimensions and Clearances

A230161

UNIT SIZE		CONSOLE	
		12K	
		DIMENSIONS	
Height (H)	in (mm)	24.45(621)	
Width (W)	in (mm)	31.26(794)	
Depth (D)	in (mm)	7.87(200)	
		PACKING	
Height	in (mm)	28.31(719)	
Width	in (mm)	34.06(865)	
Depth	in (mm)	11.02(280)	
Weight-Gross	lbs (kg)	41.45(18.8)	
Weight-Net		32.85(14.9)	

SPECIFICATIONS

System	Size		12
Electrical	Voltage, Phase, Cycle	V/Ph/Hz	208/230-1-60
	Power Supply		Indoor unit powered from outdoor unit
Controls	Wireless Remote Controller (°F/°C Convertible)		Standard
	Wired Remote Controller (°F/°C Convertible)		Optional
Operating Range	Cooling Indoor DB Min - Max	°F (°C)	60~90 (16~32)
	Heating Indoor DB Min - Max	°F(°C)	32~86 (0~30)
Piping	Pipe Connection Size - Liquid	in (mm)	Ø1/4" (6.35)
	Pipe Connection Size - Suction	in (mm)	Ø1/2" (12.7)
Indoor Coil	Face Area (sq. ft)	Sq. Ft.	2.34
	No. Rows		2
	Fins per inch		20
	Circuits		2
Indoor	Unit Width	in (mm)	31.26(794)
	Unit Height	in (mm)	24.45(621)
	Unit Depth	in (mm)	7.87(200)
	Net Weight	lbs (kg)	32.85(14.9)
	No. of Fan Speeds		4
	Airflow (lowest to highest)	CFM	265/324/376/441
	Sound Pressure - Cooling (lowest to highest)	dB(A)	32.7/36.2/39/42.5
	Sound Pressure - Heating (lowest to highest)	dB(A)	31.3/34.6/37.4/40.6
	Air Throw Data	ft (m)	19.69 (6)
	Moisture Removal	Pint/h (L/h)	2.64 (1.25)
Field Drain Pipe Size O.D.	in (mm)	5/8 (17) O.D.	

*Performance may vary based on the compatible outdoor units. See the respective pages for performance data.

NOTE: Backward compatible with 38MA*R Product Family single zone and 38MGR multi-zone systems

NOTE: See the current compatibility chart for list of indoor unit and outdoor unit match ups.

COMPATIBILITY TABLE

Indoor Unit	DLFSFBH12XAK
Outdoor Unit Single Zone	DLCSRBH12AAJ
Outdoor Unit Multi-zone	DLCMRBH18BAK
	DLCMHBH24CAK
	DLCMHBH30DAK
	DLCMRBH36DAK
	DLCMHBH36DAK
	DLCMRBH48EAK
	DLCMHBH48EAK

APPLICATION DATA

Unit Selection

Select equipment to either match or is slightly less than the anticipated peak load. This provides better humidity control, fewer unit cycles, and less part-load operation.

For units used in spaces with high sensible loads, base equipment selection on unit sensible load, not on total anticipated load. Adjust for anticipated room wet bulb temperature to avoid undersizing equipment.

Unit Mounting (Indoor)

Refer to the unit's installation instructions for further details.

Unit leveling - For reliable operation, units should be level in all planes.

Clearance - Provide adequate clearance for airflow (See Fig. 2 — on page 5).

Unit location - Select a location which provides the best air circulation for the room.

These units should be positioned on the floor, against the wall for the best air circulation. The unit return and discharge should not be obstructed by furniture, curtains, or anything which may cause unit short cycling or air recirculation. Place the unit in the middle of the selected wall (if possible). Use an outside wall, if available, to make piping easier, and place the unit so it faces the normal location of room occupants.

Mounting Template

Refer to the unit's installation instructions for further details.

The fan coil units are furnished with mounting to mark the location of the wiring, and refrigeration line hole locations.

Support

Adequate support must be provided to support the weight of the fan coil. Refer to "DIMENSIONS AND CLEARANCES" on page 5 and "SPECIFICATIONS" on page 6 for the fan coil weight and the base unit dimensional drawings for the mounting brackets location.

System Operating Conditions

Operating Range Min/Max °F (°C)		
	Cooling	Heating
Indoor DB	63 / 90 (17 / 32)	32 / 86 (0 / 30)
Indoor WB	59 / 84 (15 / 29)	

NOTE: Reference the product installation instructions for more information.

Drain Connections

Install drains to meet the local sanitation codes. If adequate gravity drainage cannot be provided, the unit should be equipped with an accessory condensate pump. For the drain size, review "SPECIFICATIONS" on page 6.

Refrigerant Lines

General Refrigerant Line Sizing:

1. The outdoor units are shipped with a full charge of R410A refrigerant.
2. Refrigerant lines should not be buried in the ground. If it is necessary to bury the lines, not more than 36-in (914 mm) should be buried. Provide a minimum 6-in (152 mm) vertical rise to the service valves to prevent refrigerant migration.
3. Both lines must be insulated. Use a minimum of 1/2-in. (12.7 mm) thick insulation. Closed-cell insulation is recommended in all long-line applications.
4. Special consideration should be given to isolating the interconnecting tubing from the building structure. Isolate the tubing so that vibration or noise is not transmitted into the structure.

WIRING

All wires must be sized per NEC (National Electrical Code) or CEC (Canadian Electrical Code) and local codes. Use Electrical Data table MCA (minimum circuit amps) and MOCP (maximum over current protection) to correctly size the wires and the disconnect fuse or breakers respectively.

Recommended Connection Method for Power and Communication Wiring:

The main power is supplied to the outdoor unit. The field supplied 14/3 stranded wire with ground with a 600 volt insulation rating, power/communication wiring from the outdoor unit to indoor unit consists of four (4) wires and provides the power for the indoor unit. Two wires are line voltage AC power, one is communication wiring (S) and the other is a ground wire. Wiring between indoor and outdoor unit is polarity sensitive. The use of BX wire is **NOT** recommended.

If installed in a high Electromagnetic field (EMF) area and communication issues exists, a 14/2 stranded shielded wire can be used to replace L2 and (S) between outdoor unit and indoor unit landing the shield onto ground in the outdoor unit only.



CAUTION

EQUIPMENT DAMAGE HAZARD

Failure to follow this caution may result in equipment damage or improper operation.

Wires should be sized based on NEC and local codes.



CAUTION

EQUIPMENT DAMAGE HAZARD

Failure to follow this caution may result in equipment damage or improper operation.

Be sure to comply with local codes while running wire from the indoor unit to the outdoor unit.

Every wire must be connected firmly. Loose wiring may cause the terminal to overheat or result in unit malfunction. A fire hazard may also exist. Ensure all wiring is tightly connected.

No wire should touch the refrigerant tubing, compressor or any moving parts.

Disconnecting means must be provided and shall be located within sight and readily accessible from the air conditioner.

CONTROL SYSTEM

The unit is equipped with a microprocessor control to perform two functions:

1. Provide safety for the system
2. Control the system and provide optimum levels of comfort and efficiency.

The main microprocessor is located on the control board of the fan coil unit (outdoor units have a microprocessor too) with thermistors located in the fan coil air inlet and on the indoor coil.

Heat pump units have a thermistor on the outdoor coil. These thermistors monitor the system operation to maintain the unit within acceptable parameters and control the operating mode.

Wireless Remote Control

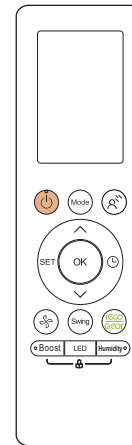

A230166

Fig. 3 —Wireless Remote RG10L3(2HS)/BGEFU1

1. A wireless remote control is supplied for system operation of the console units.
2. Each battery operated wireless (infrared) remote control may be used to control more than one unit.

Wired Remote Control (OPTIONAL)



Fig. 4 — KSACN0801AAA (Size 12)

1. Optional wired remote controller used for system operation of all console units.
2. Kit includes a wired remote controller (KSACN0801AAA) and a connecting cable.
3. Connect the wire terminal between the remote controller and the indoor unit.
4. Display in °F or °C and temperature increments every 1°F or every 1°C.



A230167

Fig. 5 —KSACN0101AAA (Timer Function)

**NOTE: Extension wire available through RCD
Part Number: 17401204001601**

KSAIC0301230 24 INTERFACE

Allows the Ductless System to be controlled using a Third Party Thermostat

AIRFLOW DATA

SYSTEM SIZE		12K
Indoor (CFM)	High	376
	Medium	324
	Low	265

SOUND PRESSURE

SYSTEM SIZE		12K
Cooling Operation Indoor Sound Pressure	dBA (40%/60%/80%/100% CFM)	32.7/36.2/39/42.5
Heating Operation Indoor Sound Pressure	dBA at (40%/60%/80%/100% CFM)	31.3/34.6/37.4/40.6

SOUND PRESSURE TESTING METHOD

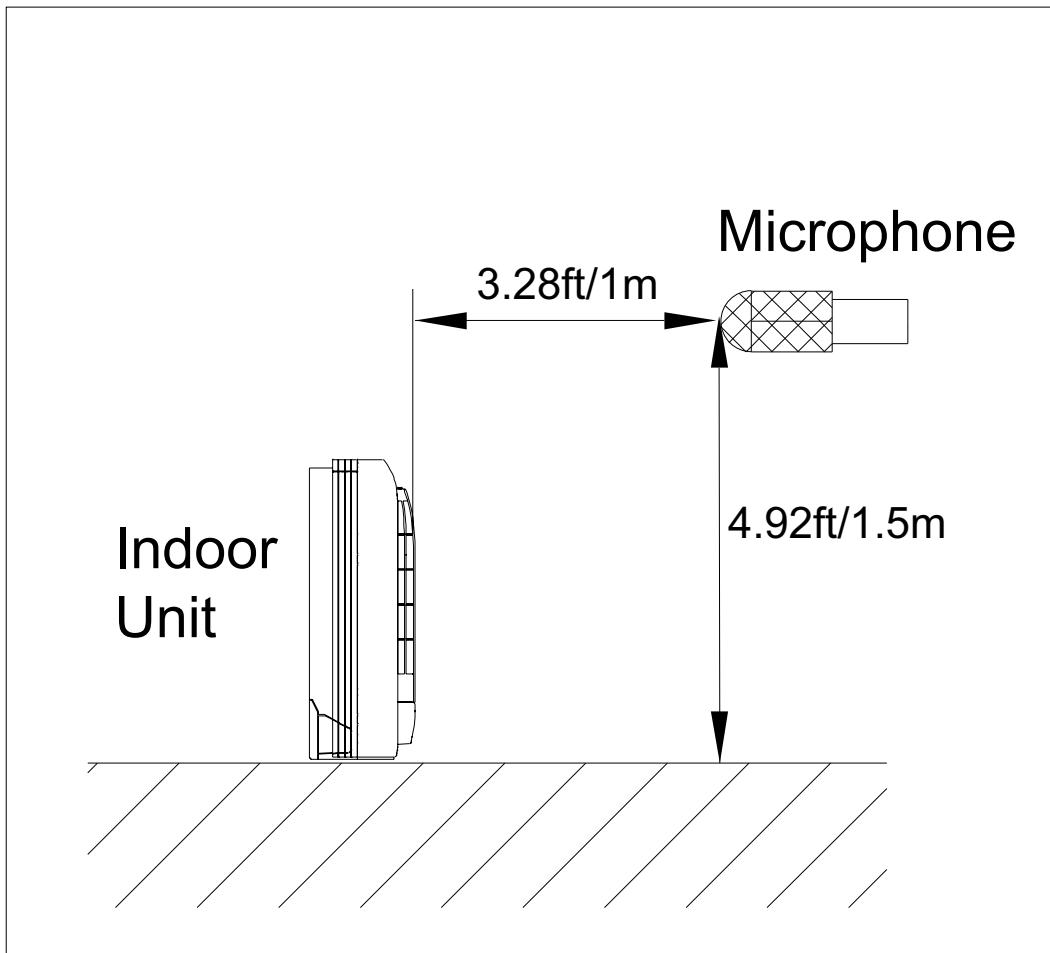

Fig. 6 —Sound Pressure Testing Method

A230169

ELECTRICAL DATA

INDOOR UNIT	INDOOR FAN				MAX FUSE CB AMP
	V-PH-HZ	FLA (A)	HP	SYSTEM POWER FACTOR (%)	
12K	208-230/1/60	0.5	1/55	95.6	Refer to outdoor unit installation instructions. Indoor unit is powered by the outdoor unit.

LEGEND

FLA - Full Load Amps

FAN AND MOTOR SPECIFICATIONS

			12K (208/230 V)
INDOOR FAN	Diameter	inch (mm)	3.86(98)
	Height	inch (mm)	21.18(538)
INDOOR FAN MOTOR	Model		ZKFP-13-8-136
	Volts	V	310
	Type		DC
	Phase		3
	FLA		0.5
	Insulation class		B
	Safe class		IP20
	Input	W	32
	Output	W	13
	Range of current	Amps	0.66±10%
	Rated current	Amps	0.31
	Rated HP	HP	1/55
	Speed	rev/min	992/884/776
Rated RPM	rev/min	992	
Max. input	W	74	

WIRING DIAGRAM

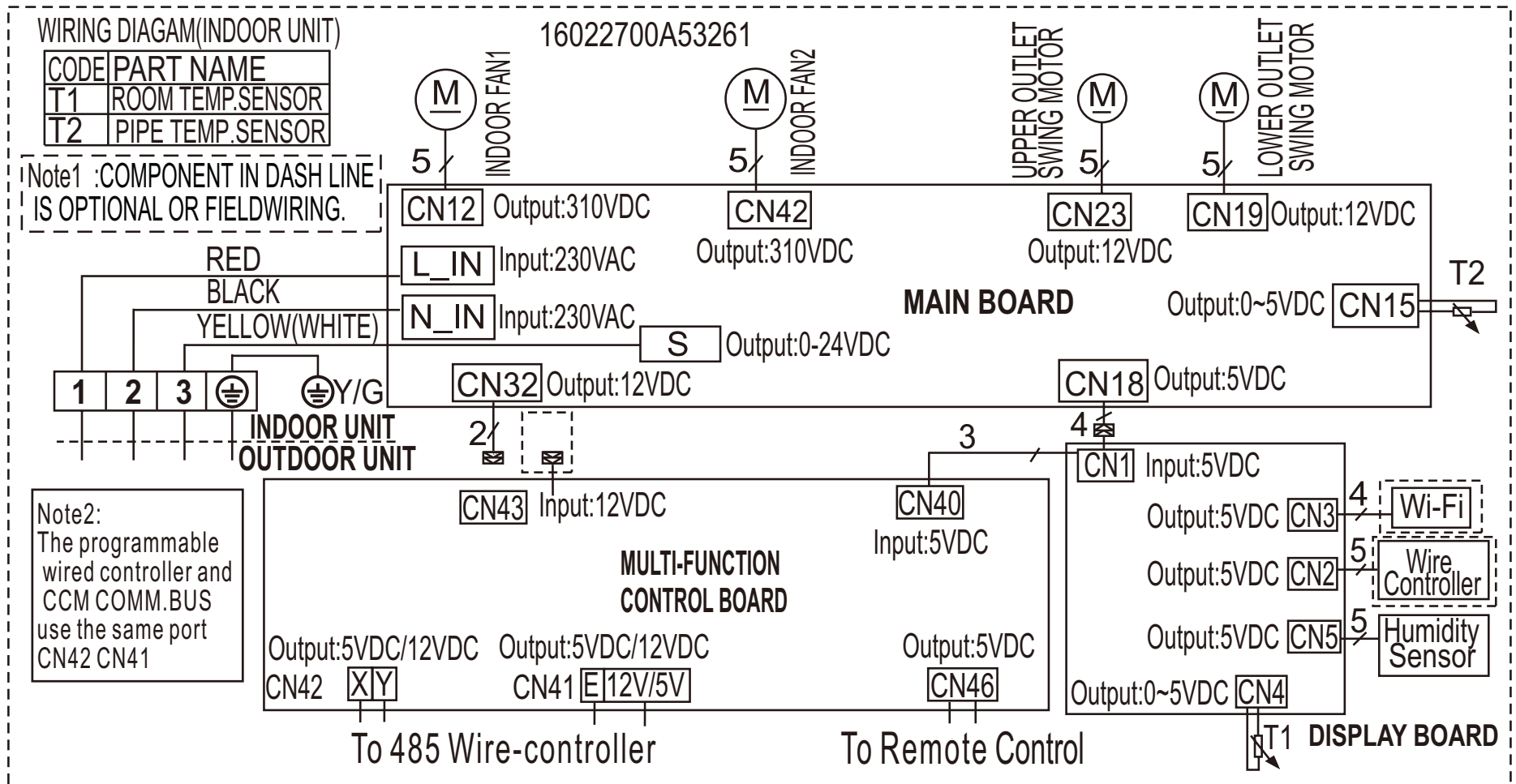

Fig. 7 —Wiring Diagram Size 12

A230170

Part 1 - GENERAL

1.01 System Description

Indoor console, direct-expansion fan coils are matched with a cooling only or heat pump outdoor unit.

1.02 Agency Listings

Unit is rated per AHRI Standards 210/240 and listed in the AHRI directory as a matched system.

1.03 Delivery, Storage, And Handling

Units are stored and handled per the unit manufacturer's recommendations.

1.04 Warranty (For Inclusion By Specifying Engineer)

Part 2 - PRODUCTS

2.01 Equipment

A. General:

Indoor, direct-expansion, floor-mounted fan coil. Unit is complete with a cooling/heating coil, fan, fan motor, piping connectors, electrical controls, microprocessor control system, and integral temperature sensing. Unit is furnished with an integral mounting bracket and mounting hardware.

B. Unit Cabinet:

Cabinet discharge and inlet grilles are attractively styled, high-impact polystyrene. Cabinet is fully insulated for improved thermal and acoustic performance.

C. Fans:

1. Fan is the tangential direct-drive blower type with an air intake in the center of the unit and discharge at the top and bottom front. An automatic, motor-driven vertical air sweep is provided standard.
2. Air sweep operation is user selectable. The vertical sweep may be adjusted (using the remote control) and the horizontal air direction may be set manually.

D. Coil:

Coil is a copper tube with aluminum fins and galvanized steel tube sheets. Fins are bonded to the tubes by mechanical expansion and specially golden hydrophilic pre-coated for enhanced wet-ability. A drip pan under the coil has a drain connection for hose attachment to remove condensate. The condensate pan has an internal trap.

E. Motor:

The motor has an open drip-proof, permanently lubricated ball bearing with inherent overload protection. The fan motor has 4-speeds.

F. Controls:

Controls consist of a microprocessor-based control system which controls the space temperature, determines the optimum fan speed, and runs self diagnostics. The temperature control ranges from 62°F to 86°F (17°C to 30°C) in increments of 1°F or 1°C, and have 46°F Heating Mode (Heating Setback). The wireless remote controller has the ability to act as the temperature sensing location for room comfort.

GUIDE SPECIFICATIONS INDOOR CONSOLE DUCTLESS UNITS

Size Range: 1 to 5 Ton Nominal Cooling and Heating Capacity Model Number:DLFSFBH

The unit has the following functions as a minimum:

1. An automatic restart after power failure at the same operating conditions as at failure.
 2. A timer function to provide a minimum 24-hour timer cycle for system Auto Start/Stop.
 3. Temperature-sensing controls to sense the return air temperature.
 4. Indoor coil freeze protection.
 5. Wireless infrared remote control to enter set points and operating conditions.
 6. Automatic air sweep control to provide on or off activation of air sweep louvers.
 7. Dehumidification mode to provide increased latent removal capability by modulating system operation and set point temperature.
 8. Fan-only operation to provide room air circulation when no cooling is required.
 9. Diagnostics to conduct continuous checks of unit operation and warn of possible malfunctions. Error messages appear on the unit.
 10. Fan speed control is user-selectable: high, medium, low, or microprocessor controlled automatic operation during all operating modes.
 11. Automatic heating-to-cooling changeover in heat pump mode. Control includes a deadband to prevent rapid mode cycling between heating and cooling.
 12. Indoor coil high temperature protection is provided to detect excessive indoor discharge temperature when the unit is in heat pump mode.
- G. Filters:**
Unit has a filter track with factory-supplied cleanable filters.
- H. Electrical Requirements:**
Indoor fan motor to operate on 208-230V as specified. Power is supplied from the outdoor unit.
- I. Operating Characteristics:**
The DLFSFBH system has a minimum SEER (Seasonal Energy Efficiency Ratio) and HSPF at AHRI conditions, as listed on the specifications table of the outdoor unit.
- J. Refrigerant Lines:**
All units should have refrigerant lines that can be oriented to connect from the left, right or back of unit. Both refrigerant lines need to be insulated.



Viessmann Manufacturing Company (U.S.) Inc.
 45 Access Road
 Warwick, Rhode Island · 02886 · USA
 TechInfo Line 1-888-484-8643
 1-800-288-0667 · Fax (401) 732-0590
 www.viessmann-us.com · info@viessmann-us.com

Viessmann Manufacturing Company ULC
 750 McMurray Road
 Waterloo, Ontario · N2V 2G5 · Canada
 TechInfo Line 1-888-484-8643
 1-800-387-7373 · Fax (519) 885-0887
 www.viessmann.ca · info@viessmann.ca

