



GAS CONDENSING TECHNOLOGY

Prefabricated multiple-boiler system

VITODENS 200-W, CASCADE



A powerful commercial heating system

A flexible solution with maximum efficiency and high performance.

Cascade systems
14-4240MBH

In a cascade system, the Vitodens 200 becomes a powerful commercial heating system capable of satisfying even the largest commercial heating loads.

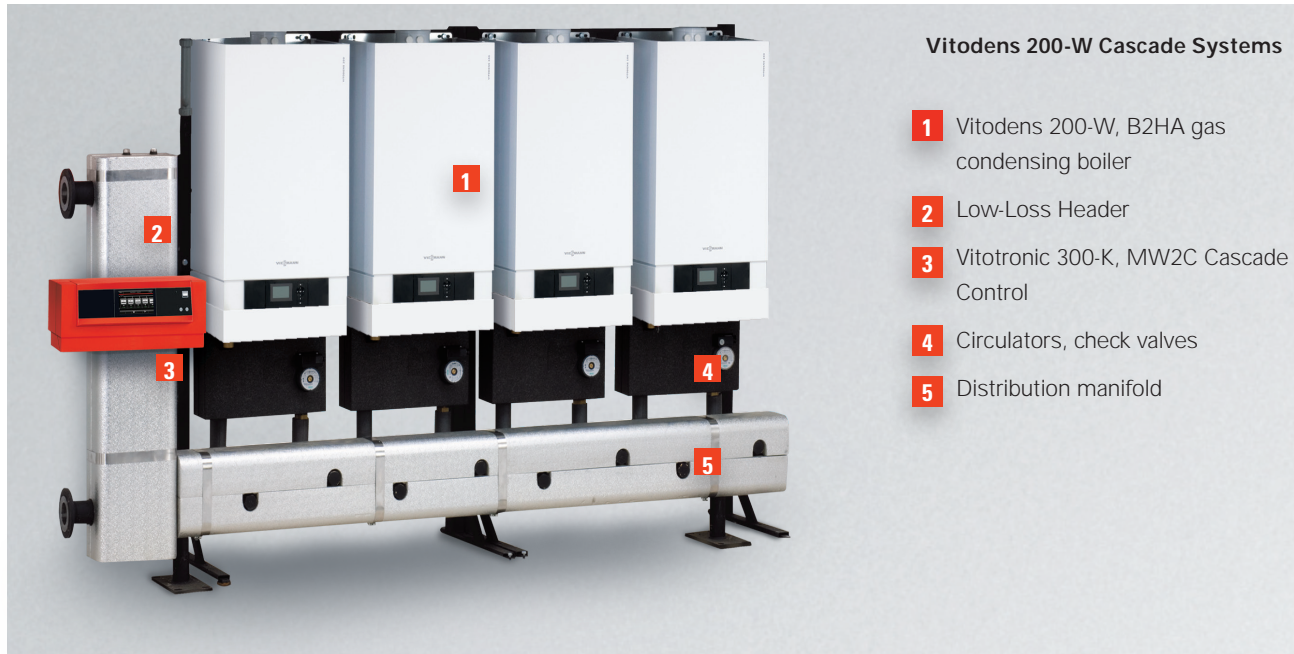

Product not exactly as shown.

Vitodens 200-W Cascade Systems

- 1 Vitodens 200-W, B2HA gas condensing boiler
- 2 Low-Loss Header
- 3 Vitotronic 300-K, MW2C Cascade Control
- 4 Circulators, check valves
- 5 Distribution manifold

Performance and efficiency

The Vitodens 200 is one of the most efficient and powerful wall-mounted condensing boilers on the market. By itself, it is ideally suited for residential applications. But in a cascade system, the Vitodens 200 becomes a powerful commercial heating system capable of satisfying even the largest commercial heating loads.

Equipped with proven Viessmann technology, including the Matrix cylinder burner and Inox-Radial heat exchanger, the Vitodens 200 delivers outstanding performance. Plus, with the Lambda Pro® combustion management system, each Vitodens 200 in your cascade system will operate at maximum efficiency, reducing heating costs without compromising comfort.

Strength in numbers

As many as eight Vitodens 200 gas-fired condensing boilers can be combined in a single prefabricated cascade system, with inputs up to 4240 MBH. A cascade system fires boilers as required to meet fluctuating heating demands; it maintains maximum efficiency at all times by precisely matching the load.

A cascade system can also prevent interruption of heating plant operation, with multiple boilers available as back-up.

Portable and convenient

The Vitodens 200 cascade system is your most flexible installation option for problematic retrofits and small spaces. The prefabricated distribution manifold is floor-mounted and is available in a variety of configurations: single-line, corner or back-to-back for ultimate installation flexibility.

With all components individually packaged, the cascade system is ideal for small or difficult-to-access boiler rooms or facilities with narrow halls or stairwells.

Easy installation

The Low-Loss Header increases operational efficiency of a cascade system by ensuring low return temperatures and acting as a hydraulic break – decoupling boilers and system circuits. Right or left-mount, the Low-Loss Header allows the cascade to be installed in a variety of configurations. The system's prefabricated distribution manifold allows boilers to be easily field assembled, wired and piped prior to system installation.

The Vitodens 200 is ENERGY STAR® qualified. By choosing the Vitodens 200, you are helping to promote cleaner air and a healthier environment.



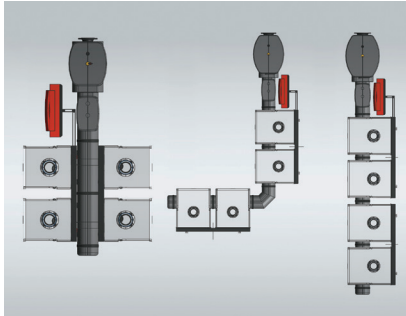

The prefabricated distribution manifold is available in a variety of configurations: single-line, corner or back-to-back.

Controlling your cascade

Get the best performance from your multiple-boiler installations with the Vitotronic 300-K, MW2C Cascade Control. This advanced digital boiler and system control with outdoor reset function ensures reliable and efficient performance of a cascade system with up to eight boilers (with Vitotronic 200, HO1B controls).

The Vitotronic 300-K control will modulate, stage and rotate boilers, regulate boiler water and common supply temperature, and with optional extension module, can control up to two heating circuits with mixing valves. Plus, set-up is fast and easy with its plug-and-play function for automatic recognition and adaptation of sensors and system accessories.

The Vitotronic 300-K control also allows seamless integration into Building Management Systems (BMS) without additional gateway (limited access). Use of commercially available LON equipment for further inputs and outputs is optional (coupling via standard LON tools up to three heating circuits).

BENEFITS AT A GLANCE

- + Outstanding performance with Vitodens 200 and Lambda Pro combustion management system
- + Maximum efficiency with high turndown that precisely matches load
- + Simplified boiler system layout as manifold and Low-Loss Header provide complete primary loop
- + Multiple boilers secure against interruption of heating plant operation
- + Boilers easily assembled and hydraulically connected prior to installation with prefabricated manifold
- + Flexible installation with multiple manifold configurations: floor standing, corner, or back-to-back
- + Right or left-mount Low-Loss Header acts as hydraulic break and helps eliminate air and debris
- + Ideal for small or difficult-to-access boiler rooms or facilities with narrow halls and stairwells
- + All serviceable components easily accessible from the front
- + No pipe or manifold sizing required
- + Offered in packaged system
- + Common venting up to four boilers‡

‡ In accordance with local codes and regulations of authorities having jurisdiction



Vitotronic control

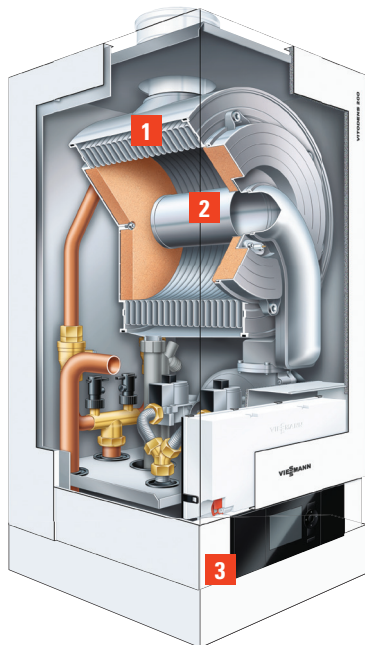

VITODENS 200-W, B2HA

- 1 Inox-Radial heat exchanger
- 2 Modulating Matrix cylinder burner
- 3 Vitotronic 200 control with graphic user interface

SPECIFICATIONS

- + For two to eight Vitodens 200, B2HA boilers in a single cascade
- + The distribution manifolds are checked for proper alignment and have a maximum operating pressure of 80 psig
- + Vitotronic 300-K control with outdoor reset function and integration with BMS (additional components required)
- + All ANSI flange connections



Note: Vitodens 200-W B2HE boilers have a built-in cascade system (not compatible with Vitodens 200-W B2HA cascading system). For cascading any E-series boilers please refer to the technical documentation manual.

Technical Information

VITODENS 200-W CASCADE

Viessmann Manufacturing
Company Inc.
Waterloo, ON Canada
(800) 387-7373
viessmann.ca

Viessmann Sales Office
Langley, BC Canada
(877) 853-3288

Technical Data

Model		B2HA					B2HE	
		285	311	352	399	530	150	199
Min.- Max. Input (single boiler)*	MBH	71 - 285	71 - 311	71 - 352	113 - 399	113 - 530	14 - 150	14 - 199
Min.- Max. Input (multiple of 8)*	MBH	71 - 2,280	71 - 2,488	71 - 2,816	113 - 3,192	113 - 4,240	14 - 1200	14 - 1592
Weight (single boiler)	lbs	194	194	194	298	298	179	179

* Input based on natural gas

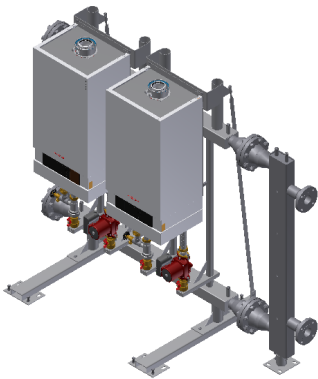

2-boiler cascade system

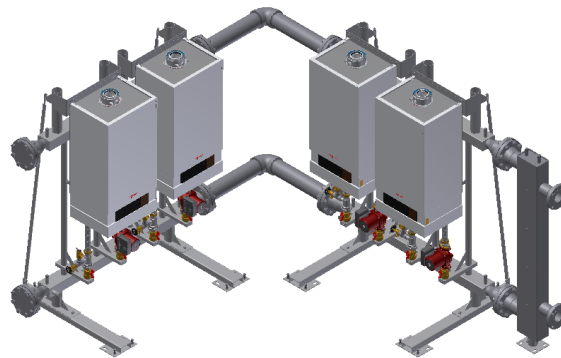

4-boiler cascade system in corner configuration

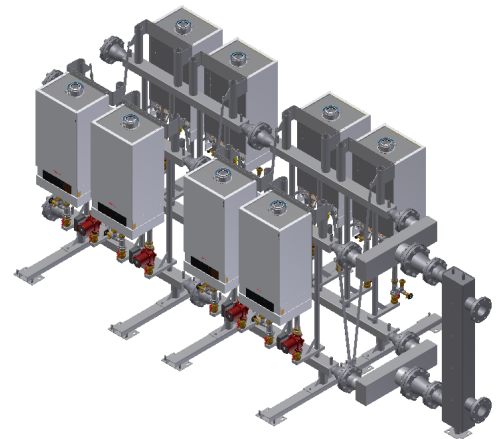

8-boiler cascade system in back-to-back configuration

