

Technical Data Manual

for use by heating contractor

VIESSMANN®

Vitorond 200 VD2 Series
Triple-pass hot water heating boiler
1255 to 4387 MBH (368 to 1285 kW)



VITOROND 200



Product may not be exactly as shown

Vitorond 200 Oil-/Gas-fired boiler

sectional cast iron design with Eutectoplex heat transfer surface, in triple-pass design
for operation with modulating water temperatures

Heating input: 1255 to 4387 MBH
(368 to 1285 kW)



Safety and Installation Requirements

Please ensure that these instructions are read and understood before starting any service work. Failure to comply with these instructions may cause product/property damage, severe personal injury and/or loss of life.

Working on the equipment

The installation, adjustment, service and maintenance of this product must be performed by a licensed professional heating contractor who is qualified and experienced in the installation, service, and maintenance of hot water boilers. There are no user serviceable parts on the boiler, burner or control.

Ensure that main power to the equipment being serviced is off.

Ensure that the main fuel supply valve to the boiler is closed.

Take precautions to avoid accidental activation of power or fuel during service work.

Do not perform service work on any component part without ensuring safe operation of the heating system. When replacing parts, use original Viessmann or Viessmann approved replacement parts.



Refer to the Installation Instructions applicable to this boiler.

Product Information

VITOROND 200

The modular sectional cast iron design of the Vitorond 200, VD2 allows for problem-free transport into difficult-to-access boiler rooms and permits easy assembly.

The triple-pass design ensures clean, low-emission combustion, while the Eutectoplex heat exchanger surface guarantees economical energy consumption, high operational reliability and a long service life.

The benefits at a glance:

- Eutectoplex heat exchanger surface for high operational reliability and a long service life.
The homogeneous structure of the Eutectoplex special gray cast iron ensures uniform heat transfer, minimizing stress fractures and counteracting the formation of condensate.
Shape and geometry of the cast iron sections, excellent water flow characteristics and uniform temperature distribution further increase the level of operational reliability.
- Problem-free transport into difficult-to-access boiler rooms due to sectional construction and low weight of individual sections.
- Efficient and environmentally friendly operation due to modulated boiler water temperatures.
Combustion efficiency up to:
 - oil88.1%.
 - gas85.5%.
 Thermal efficiency up to:
 - oil88.0%.
 - gas85.4%.
- Low-emission combustion through triple-pass design.
- Simple, quick assembly of the individual cast iron sections is achieved with a double-groove seal fit system for the flue gas passageways. The gasket seal is secured in place by the double groove, and therefore not subject to mechanical stresses.
- Easy cleaning access facilitated by a hinged (left or right) swing-open combustion chamber door, allowing easy access to all three heat exchanger passes from boiler front, reducing side clearance.
- Economical and safe operation of the heating system with Vitotronic or Dekamatik digital boiler and heating system control.
Tailored to suit every requirement, these controls cover all known control strategies and applications.
- Economical and hygienic domestic hot water production with indirect-fired Vitocell 100 steel or Vitocell 300 stainless steel tanks.
Tanks may be combined into multiple-tank batteries for applications requiring larger quantities of hot water.

Product Information

Standard Equipment

	Page
Safety and Installation Requirements	2
Working on the equipment	2
Product Information	2
VITOROND 200.....	2
The benefits at a glance:	2
Cut-Away Section	4
Technical Data	5
Operational Details	13
Operational Details.....	13
Requirements are fulfilled via.....	13
Standard Equipment	13
Boiler Control Alternatives	14
For single boiler systems:.....	14
Vitotronic 100 (type GC1B).....	14
Vitotronic 300 (type GW2).....	14
Vitotronic 100 (type GC1B).....	14
Vitotronic 300-K MW1B control panel.....	14
For multi-boiler system (up to 4 boilers):	14
Vitotronic 100 (type GC1B) and LON module	14
Vitotronic 100 (type GC1B) and LON module	14
Vitotronic 300-K MW1B control panel	14
For single or multiple-boiler installations:	14
Custom control panels.....	14
System Design Considerations	15
Burner calibration.....	15
2-Stage burner	15
Fully modulating burner	15
Venting	15
Chimney	15
Barometric draft regulator type	16
Barometric draft regulator diameter	16
Venting option #2 (Category III).....	16
Combustion air supply	16
Warranty	16
System layout	16
Water quality	17
Oxygen diffusion barrier underfloor tubing.....	17
Burner Alternatives	17
Burner manufacturer	17
Burner/Gas train approval.....	17
Electrical requirements	17
Natural gas pressure	17
Factory pre-wired components	17
Boiler/Burner start-up	17
Weishaupt Burners, Linkageless	18
Riello Burners	18

Cut-Away Section

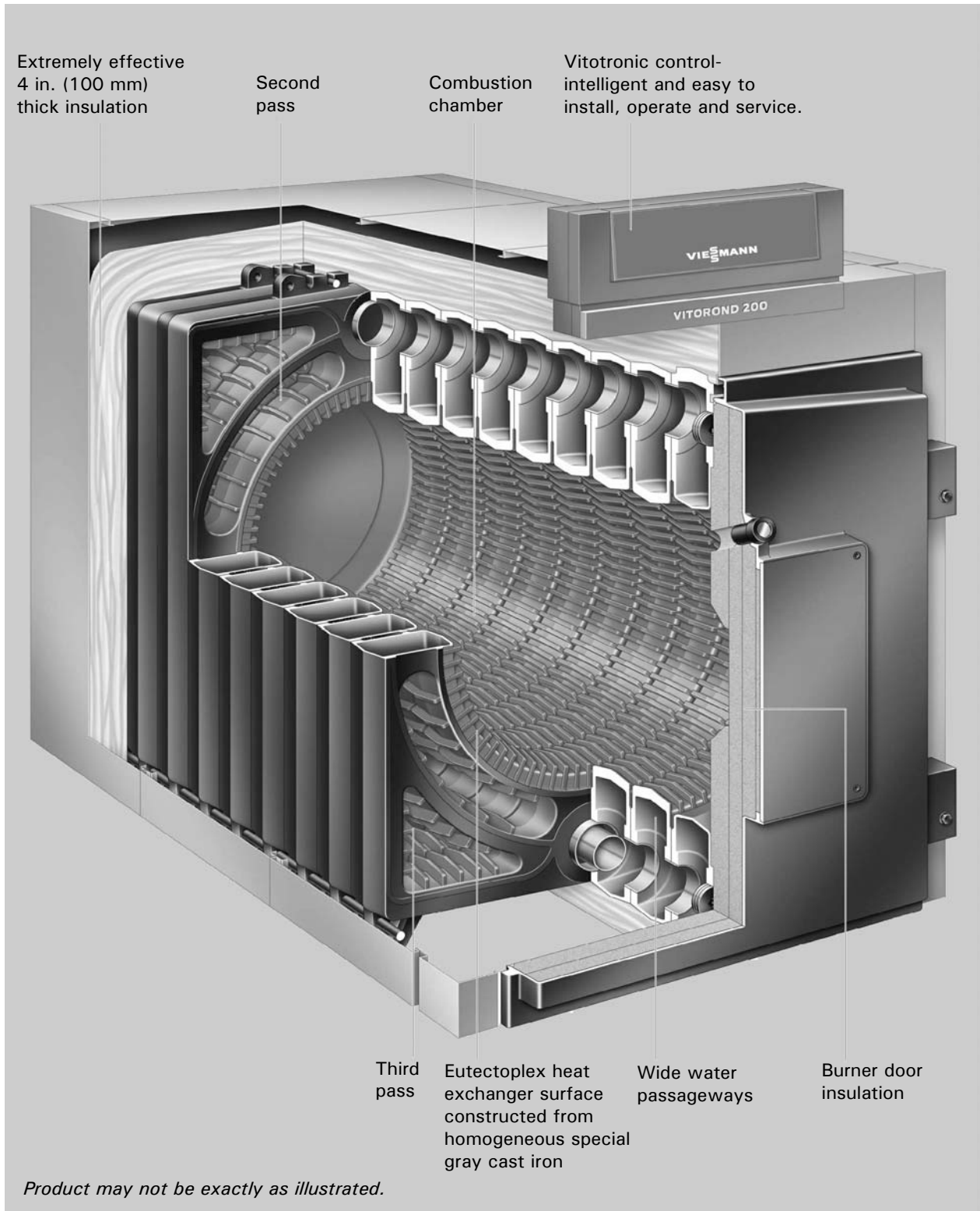

Technical Data

Technical Data *1

Boiler Model	VD2-	320	380	440	500	560	630	700	780	860	950	1080
Input (oil) *1	MBH (kW)	1255 (368)	1490 (436)	1726 (506)	1961 (574)	2196 (643)	2471 (724)	2745 (804)	3059 (896)	3373 (988)	3727 (1091)	4236 (1241)
Input (gas) *1	MBH (kW)	1300 (381)	1544 (452)	1787 (523)	2031 (595)	2275 (666)	2559 (750)	2843 (833)	3168 (928)	3493 (1023)	3860 (1130)	4387 (1285)
Output (oil/gas) *2	MBH (kW)	1110 (325)	1319 (387)	1526 (447)	1732 (508)	1941 (569)	2183 (640)	2425 (711)	2699 (791)	2976 (872)	3288 (963)	3738 (1095)
Combustion efficiency (oil)	%	88.1	88.0	88.0	87.9	87.8	87.8	87.7	87.6	87.5	87.4	87.3
Combustion efficiency (gas)	%	85.5	85.4	85.4	85.3	85.2	85.1	85.1	85.0	84.9	84.8	84.6
Thermal efficiency (oil)	%	88.0	88.0	88.0	88.0	88.0	87.9	87.9	87.9	87.9	87.8	87.8
Thermal efficiency (gas)	%	85.4	85.4	85.4	85.3	85.3	85.3	85.3	85.2	85.2	85.2	85.2
Number of cast iron sections		9	10	11	12	13	14	15	16	17	18	19

Cast iron block dimensions

Length	in. (mm)	57 (1450)	62 (1580)	67 (1710)	72 (1840)	77½ (1970)	82½ (2100)	88 (2230)	93 (2360)	98 (2490)	103 (2620)	108 (2750)
Width	in. (mm)	40½ (1030)	40½ (1030)	40½ (1030)	40½ (1030)	40½ (1030)	40½ (1030)	40½ (1030)	40½ (1030)	40½ (1030)	40½ (1030)	40½ (1030)
Height	in. (mm)	45¼ (1150)	45¼ (1150)	45¼ (1150)	45¼ (1150)	45¼ (1150)	45¼ (1150)	45¼ (1150)	45¼ (1150)	45¼ (1150)	45¼ (1150)	45¼ (1150)

Cast iron section dimensions

Front section (with combustion chamber door)	in. (mm)	45¼ x 40½ x 10¾ (1150 x 1030 x 270)										
Intermediate section	in. (mm)	45¼ x 36¼ x 5 (1150 x 920 x 125)										
Rear section (with flue gas collar)	in. (mm)	45¼ x 36¼ x 9 (1150 x 920 x 290)										

Note: Dimensions are rounded to the nearest ¼ inch.

*1 Input ratings are based on ANSI Z21.13a*CSA 4.9a-2005 - Gas Fired Steam and Hot Water Boilers; CSA B140.7-05 - Oil Burning Equipment - Steam and Hot Water Boilers; CSA B140.0-03 - Oil Burning Equipment - General Requirements; UL 726 - 7th ed. - Oil-Fired Boiler Assemblies; and UL 795 - Commercial Industrial Gas Heating Equipment.

*2 Tested to AHRI BTS-2000 "method to determine efficiency of commercial space heating boilers".

Technical Data *(continued)***Technical Data**

Boiler Model	VD2-	320	380	440	500	560	630	700	780	860	950	1080
Dimensions (with insul. jacket)												
Total length	in. (mm)	58 ³ / ₄ (1490)	63 ³ / ₄ (1620)	68 ³ / ₄ (1750)	73 ³ / ₄ (1870)	78 ³ / ₄ (2000)	83 ³ / ₄ (2130)	89 (2260)	93 ³ / ₄ (2380)	98 ³ / ₄ (2510)	104 (2640)	108 ³ / ₄ (2760)
Total width with Vitotronic control (side-mounted)	in. (mm)	49 ¹ / ₄ (1250)	49 ¹ / ₄ (1250)	49 ¹ / ₄ (1250)	49 ¹ / ₄ (1250)	49 ¹ / ₄ (1250)	49 ¹ / ₄ (1250)	49 ¹ / ₄ (1250)	49 ¹ / ₄ (1250)	49 ¹ / ₄ (1250)	49 ¹ / ₄ (1250)	49 ¹ / ₄ (1250)
Total height	in. (mm)	50 ³ / ₄ (1290)	50 ³ / ₄ (1290)	50 ³ / ₄ (1290)	50 ³ / ₄ (1290)	50 ³ / ₄ (1290)	50 ³ / ₄ (1290)	50 ³ / ₄ (1290)	50 ³ / ₄ (1290)	50 ³ / ₄ (1290)	50 ³ / ₄ (1290)	50 ³ / ₄ (1290)
Weight												
Front section (with combustion chamber door)	lbs. (kg)	529 (240)	529 (240)	529 (240)	529 (240)	529 (240)	529 (240)	529 (240)	529 (240)	529 (240)	529 (240)	529 (240)
Intermediate section	lbs. (kg)	353 (160)	353 (160)	353 (160)	353 (160)	353 (160)	353 (160)	353 (160)	353 (160)	353 (160)	353 (160)	353 (160)
Rear section (with flue gas collar)	lbs. (kg)	507 (230)	507 (230)	507 (230)	507 (230)	507 (230)	507 (230)	507 (230)	507 (230)	507 (230)	507 (230)	507 (230)
Cast iron heat exchanger block	lbs. (kg)	3748 (1700)	4100 (1860)	4453 (2020)	4762 (2160)	5115 (2320)	5423 (2460)	5776 (2620)	6085 (2760)	6437 (2920)	6790 (3080)	7143 (3240)
Overall weight complete with insulation	lbs. (kg)	3924 (1780)	4299 (1950)	4652 (2110)	4982 (2260)	5335 (2420)	5666 (2570)	6019 (2730)	6349 (2880)	6702 (3040)	7070 (3210)	7429 (3370)
Boiler water content	USG (L)	65 (247)	73 (275)	80 (303)	87 (331)	95 (359)	102 (387)	110 (415)	117 (443)	124 (471)	132 (499)	139 (527)
Max. boiler temperature * ³ (= fixed high limit)	°F (°C)	248 (120)	248 (120)	248 (120)	248 (120)	248 (120)	248 (120)	248 (120)	248 (120)	248 (120)	248 (120)	248 (120)
Max. allow. operating pressure * ⁴	psig	75	75	75	75	75	75	75	75	75	75	75

Note: Dimensions are rounded to the nearest 1/4 inch.

*³ The maximum supply operating temperature (= max. adjustable high limit) lies approx. 27°F (15°C) below the fixed high limit setting.

*⁴ May be less in some Canadian provinces.

Technical Data *(continued)*

Technical Data												
Boiler Model	VD2-	320	380	440	500	560	630	700	780	860	950	1080
Boiler connections												
Boiler supply and return	in.	4	4	4	4	4	4	4	4	4	4	4
Safety supply* ⁵	in.	2½	2½	2½	2½	2½	2½	2½	2½	2½	2½	2½
Safety return* ⁵	in.	2½	2½	2½	2½	2½	2½	2½	2½	2½	2½	2½
Drain valve	in.	¾	¾	¾	¾	¾	¾	¾	¾	¾	¾	¾
Heating surface area												
Flue gas side	ft ² (m ²)	170 (15.8)	196 (18.2)	212 (19.7)	232 (21.5)	254 (23.6)	274 (25.5)	296 (27.5)	317 (29.5)	339 (31.5)	358 (33.3)	380 (35.3)
Water side	ft ² (m ²)	98 (9.1)	109 (10.1)	120½ (11.2)	131 (12.2)	142 (13.2)	153 (14.2)	165 (15.3)	175 (16.3)	18.7 (17.4)	198 (18.4)	209 (19.4)
Flue gas*⁶												
- Temperature (gross)* ⁷	°F (°C)	374 (190)	374 (190)	374 (190)	374 (190)	374 (190)	374 (190)	374 (190)	374 (190)	374 (190)	383 (195)	383 (195)
- Flue gas mass flow rate	lbs./h (kg/h)	1301 (590)	1598 (725)	1854 (841)	2081 (944)	2337 (1060)	2601 (1180)	2897 (1314)	3196 (1450)	3527 (1600)	3825 (1735)	4277 (1940)
With minimum heating input and a 2-stage burner (operation of stage 1)												
- Temperature	°F (°C)	266 (130)	266 (130)	266 (130)	266 (130)	266 (130)	266 (130)	266 (130)	266 (130)	266 (130)	275 (135)	275 (135)
- Flue gas mass flow rate at min. input rate	lbs./h (kg/h)	710 (322)	842 (382)	974 (442)	1109 (503)	1241 (563)	1398 (634)	1552 (704)	1730 (785)	1907 (865)	2110 (957)	2394 (1086)
Boiler standby loss based on max. heating input and hot water supply and return temps. of 167 / 140°F (75 / 60 °C)	%	0.40	0.38	0.35	0.32	0.31	0.29	0.28	0.27	0.26	0.25	0.24
Vent pipe collar outer ∅* ⁸	in. (mm)	12 (300)	12 (300)	12 (300)	12 (300)	12 (300)	12 (300)	12 (300)	12 (300)	12 (300)	12 (300)	12 (300)
Flue gas resistance - at upper end of rated input	"w.c. (mbar)	0.20 (0.5)	0.35 (0.9)	0.51 (1.3)	0.67 (1.7)	0.75 (1.9)	0.83 (2.1)	1.10 (2.8)	1.54 (3.9)	1.93 (4.9)	1.77 (4.5)	2.28 (5.8)
Required flue draft Category I	Pa "w.c.	0 (0)	0 (0)	0 (0)	0 (0)	0 (0)	0 (0)	0 (0)	0 (0)	0 (0)	0 (0)	0 (0)
Positive pressure Category III	Pa "w.c.	20 (0.08)	20 (0.08)	20 (0.08)	20 (0.08)	20 (0.08)	20 (0.08)	20 (0.08)	20 (0.08)	20 (0.08)	20 (0.08)	20 (0.08)

*⁵ Connections for boiler connection kit (standard equipment).

*⁶ Combustion results are based on 13.0% CO₂ with fuel oil #2 and 10% CO₂ with natural gas, as well as a system supply temperature of 167°F (75°C), and a system return temperature of 140°F (60°C).

*⁷ Measured flue gas temperature with a combustion air temperature of 68° F (20° C) and a boiler water temperature of 176°F (80°C).

*⁸ Vent pipe collar diameter does not automatically indicate vent/chimney size. See page 15 for details.

- ▶ The combustion burner head material must be suitable for temperatures of at least 932°F (500°C).
- ▶ For information regarding other Viessmann System Technology componentry, please reference documentation of respective product.

Technical Data *(continued)*

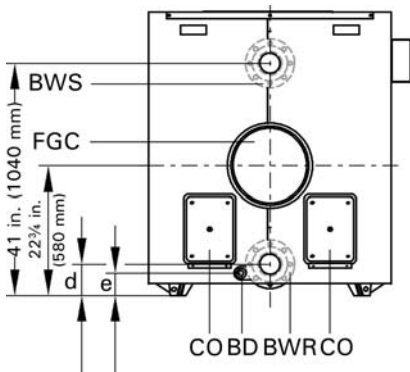
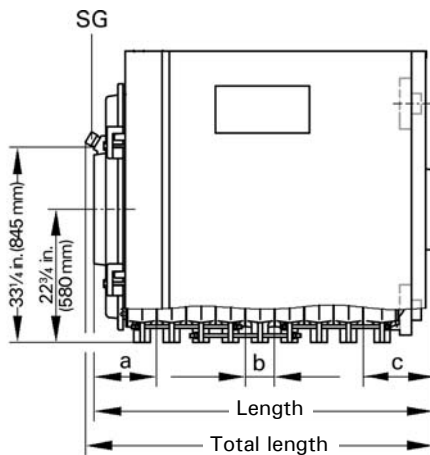
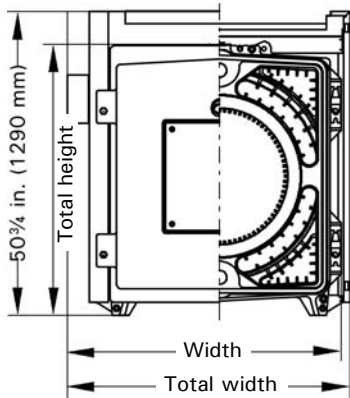

Burner Installation

The burner must be fitted to the burner plate; installations direct to the boiler door are not feasible.

Viessmann supplies a pre-drilled end burner plate in accordance with the supplied burner dimensions.

Note: For mounting burners with blast tube diameters of 7 to 11 in. (180 to 280 mm), the door insulation (refractory material) can be cut to the required size. The blast tube must protrude from the thermal insulation on the boiler door.

CAUTION

Viessmann North America offers the side-mounted control option only. Refer to the side-mounted control dimension on page 6.

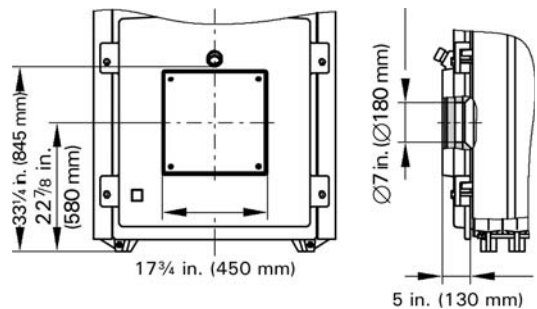

Legend

- BD Boiler drain 3/4 in.
- BWR Boiler water return
- BWS Boiler water supply
- CO Clean-out opening
- FGC Flue gas collar
- SG Sight glass
- a 10 1/2 in. (270 mm)
- b 5 in. (125 mm)
- c 11 1/2 in. (290 mm)
- d 5 1/2 in. (140 mm)
- e 4 in. (100 mm)

Technical Data *(continued)*

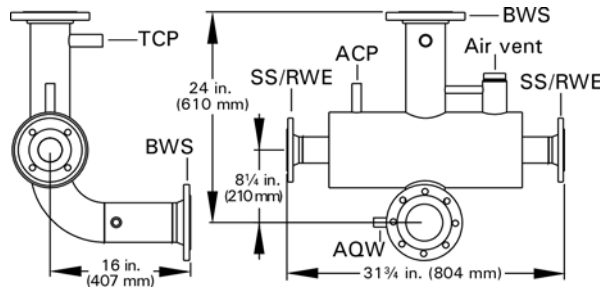

Boiler supply header

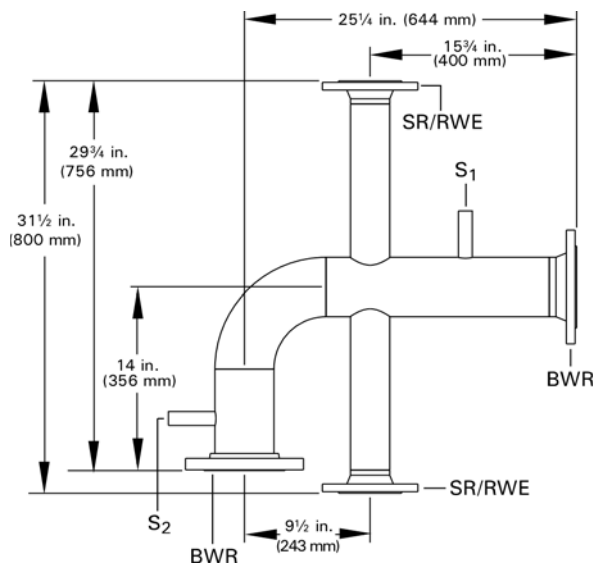

Boiler return header

Legend

- TCP Additional temperature control port 1/2 in.
- AQW Aquastat well tapping 1/2 in.
- BWR Boiler water return
- BWS Boiler water supply
- ACP Additional control port 1/2 in. (pressure gage)
- S1 Return temperature sensor port
- S2 Boiler pump temperature sensor 1/2 in.
- RWE Return water elevation 2 1/2 in.
- SR Safety return - connection to precharged membrane expansion tank
- SS Safety supply - connection to pressure relief valve

Boiler Connection Kit (Standard Equipment)

consisting of boiler supply and return header

Low temperature protection

Low temperature protection packages from Viessmann are required for Rondomat boilers. A 30% Boiler Flow Package is typically utilized in single-boiler installations. 100% Boiler Flow Packages are utilized in single- and multiple-boiler installations.

Selection of the correct package depends on the characteristics of the heating system, and the degree of control necessary to protect the boiler. Contact Viessmann for assistance.

Technical Data *(continued)*

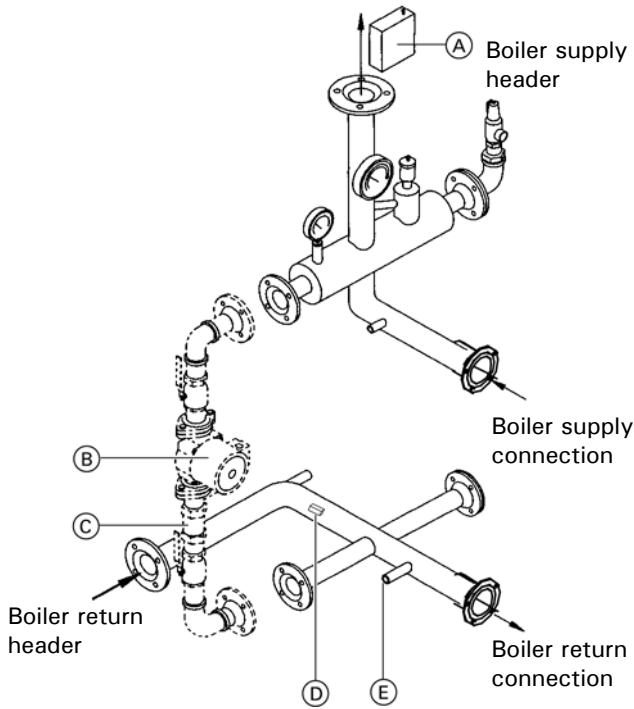

30% Boiler Flow Package

The 30% boiler flow package consists of:

- 1 circulation pump
- 1 flange set (circulation pump)
- 2 ball valves
- 1 flow check valve
- 1 17B strap on temperature sensor

Legend

- Ⓐ Low water cut-off (standard equipment)
- Ⓑ Boiler shunt pump for return water temperature elevation
- Ⓒ Flow check valve
- Ⓓ Location of 17B sensor
- Ⓔ Location of 17A sensor (installed in stainless steel well)

All boiler piping field supplied.

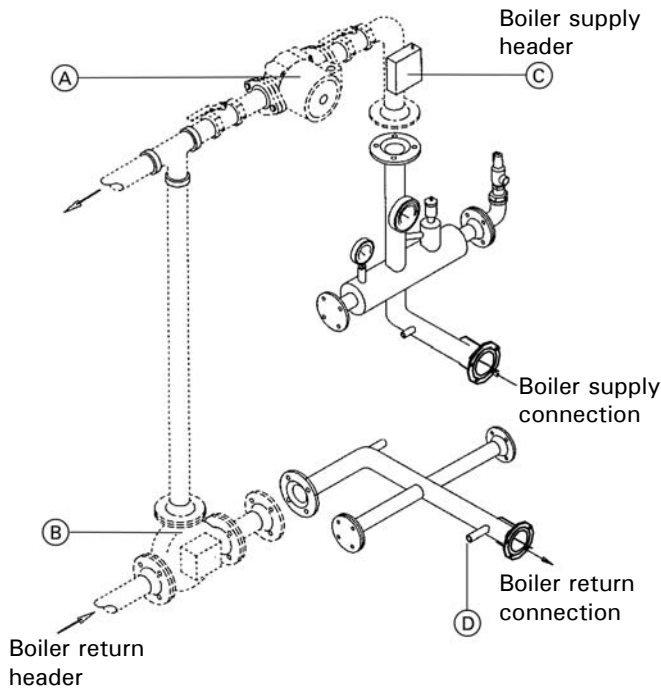

100% Boiler Flow Package

The 100% boiler flow package consists of:

- 1 3-Way return water mixing valve
- 1 actuator
- 1 circulating pump

Legend

- Ⓐ Boiler pump
- Ⓑ 3-Way mixing valve
- Ⓒ Low water cut-off (standard equipment)
- Ⓓ Location of 17A sensor (installed in stainless steel well)

All boiler piping field supplied.

IMPORTANT

It is essential that the designer review the sizing of all pumps including the boiler pump normally supplied with the 100% Boiler Flow Package to verify that all pumps in the system operate correctly. The responsibility for the distribution system design, including all circulation pumps, remains with the system designer.

Technical Data *(continued)*

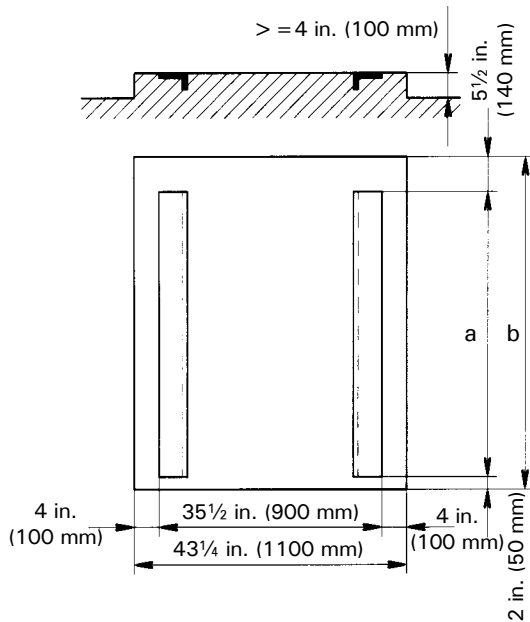

Boiler Base

The boiler must be installed on a levelled base or foundation, which must be designed to carry the entire weight of the boiler, water fill, burner and attached piping. To ease the installation of the individual sections, angle-iron or flat steel may be incorporated into the concrete foundation. Surface width of steel strips should be 4 in (100 mm).

Note: Inch dimensions rounded to the nearest 1/4 in.

Boiler model	VD2-320	VD2-380	VD2-440	VD2-500	VD2-560	VD2-630	VD2-700	VD2-780	VD2-860	VD2-950	VD2-1080
a in. (mm)	45 (1140)	49 ³ / ₄ (1265)	54 ³ / ₄ (1390)	59 ³ / ₄ (1515)	64 ¹ / ₂ (1640)	69 ¹ / ₂ (1765)	74 ¹ / ₂ (1890)	79 ¹ / ₄ (2015)	84 ¹ / ₄ (2140)	87 (2205)	94 (2390)
b in. (mm)	52 ¹ / ₄ (1330)	57 ¹ / ₄ (1455)	62 ¹ / ₄ (1580)	67 (1705)	72 (1830)	77 (1955)	82 (2080)	86 ³ / ₄ (2205)	91 ³ / ₄ (2330)	96 ¹ / ₂ (2460)	101 ¹ / ₂ (2580)

Recommended Minimum Clearances

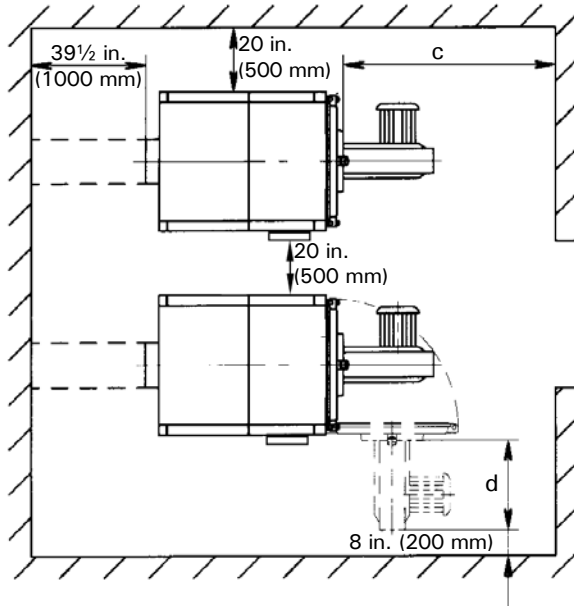

The combustion chamber door is factory assembled to hinge on the left-hand side. A right-hand hinge is feasible by rebuilding the door hinge hardware.

Front clearances (dimension "c" above) will allow for easy removal of flue gas turbulator inserts, as well as for full insertion of bristle brush for heat exchanger cleaning.

IMPORTANT

Minimum side clearance of 20 in. (500 mm) must be maintained for side-mounted Vitotronic controls.

Note: Inch dimensions rounded to the nearest 1/4 in.

Boiler model	VD2-320	VD2-380	VD2-440	VD2-500	VD2-560	VD2-630	VD2-700	VD2-780	VD2-860	VD2-950	VD2-1080
c in. (mm)	65 ¹ / ₄ (1660)	70 ¹ / ₂ (1790)	75 ¹ / ₂ (1920)	80 ³ / ₄ (2050)	85 ³ / ₄ (2180)	91 (2310)	96 (2440)	101 ¹ / ₄ (2570)	106 ¹ / ₄ (2700)	111 ¹ / ₂ (2830)	116 ¹ / ₂ (2960)
d	Dependent on burner model size										

Technical Data *(continued)*

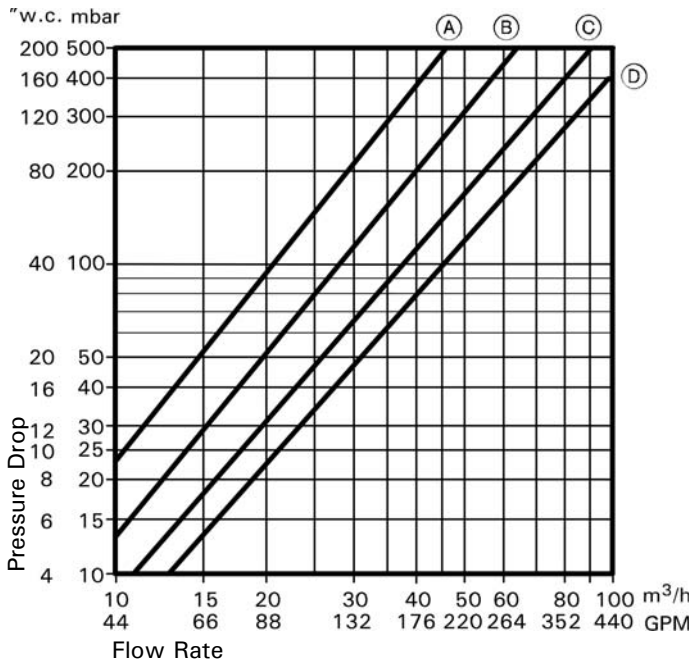

Waterside Flow

The Vitorond 200 boiler is designed for closed loop, forced circulation, hot water heating systems only.

The recommended water flow rate through the Vitorond 200 is based on a temperature difference of between 20° F and 40° F (11° C and 22° C) (see table below).

When a balancing valve is used for proper balancing and water flow through the boiler, the valve should be installed 5 pipe diameters from any fittings and 10 pipe diameters from circulation pumps to allow for laminar flow.

The consulting engineer or contractor should review the system design if more balancing valves are required to properly balance the system.

Viessmann can supply TA (Victaulic) balancing valves upon request. The balancing should be carried out by a certified balancing firm prior to boiler start-up. Please contact Viessmann for your closest certified balancing firm.

Legend

- Ⓐ VD2-320, VD2-380 and VD2-440
- Ⓑ VD2-500, VD2-560 and VD2-630
- Ⓒ VD2-700, VD2-780 and VD2-860
- Ⓓ VD2-950 and VD2-1080

Recommended Flow Rates

Boiler model	VD2-	320	380	440	500	560	630	700	780	860	950	1080
20° F Δt	GPM	109	130	150	171	191	215	239	266	293	324	369
40° F Δt	GPM	55	65	75	85	96	108	119	133	147	162	184
11° C Δt	L/sec.	6.9	8.2	9.5	10.8	12.1	13.6	15.1	16.8	18.5	20	23.2
22° C Δt	L/sec.	3.4	4.1	4.7	5.4	6.0	6.8	7.5	8.4	9.3	10.2	11.6

Δt = temperature difference

Note: This boiler does not require a flow switch.

Operational Details

Operational Details	Requirements	are fulfilled via...
Heating water volume flow	30% at heating output	a bypass pump (shunt pump or boiler circulation pump)
Boiler return water temperature (minimum)	For operation with modulating boiler water temperatures: - Oil-fired 104°F (40°C) - Gas-fired 127°F (53°C) For operation with elevated boiler water temperatures: - Oil-fired 127°F (53°C) - Gas-fired 127°F (53°C)	an effective system of return temperature elevation
Minimum boiler water temperature	For operation with modulating boiler water temperatures: - Oil-fired 122°F (50°C) - Gas-fired 140°F (60°C) For operation with elevated boiler water temperatures: - Oil-fired 140°F (60°C) - Gas-fired 149°F (65°C)	The Viessmann Vitotronic control system
2-Stage burner operation	For operation with modulating boiler water temperatures: first stage 60% of heating output For operation with elevated boiler water temperatures: No minimum heating input applies	Burner calibration (site)
Modulating burner operation	For elevated boiler water temperatures only: - Oil-fired 140°F (60°C) - Gas-fired 149°F (65°C) - min. return water temperature 127°F (53°C)	The Viessmann or Vitotronic control system
Setback operation	Minimum boiler water temperature: - Oil-fired 122°F (50°C) - Gas-fired 140°F (60°C) For multiple-boiler installations: - Lead boiler as above - Lag boiler(s) is/are deactivated	The Viessmann control included in the standard equipment
Weekend setback	See Setback operation	See Setback operation

Standard Equipment

Note: Boiler controls and burners are purchased separately. Please see Price List for details.

- The cast iron sections are delivered as individual units on skids.
- The combustion chamber door is mounted on the front section.
- The flue gas collector, with two inspection opening covers (fastened with screws), is mounted on the rear section.

- 1 skid containing supply and return headers
- 3 cartons containing insulation panels
- 1 carton containing the boiler control
- 1 carton with miscellaneous boiler assembly components

Standard equipment includes:

- Supply/Return header (c/w left/right connections)
- Low water cut-off
- Thermometer, pressure gage, air vent, pressure relief valve, and boiler drain valve

IMPORTANT

Ensure specific regional, provincial, or state requirements, such as fuel train and additional safety control requirements etc., are known before the product order is placed, to determine proper burner selection and pricing.

Boiler Control Alternatives

For single boiler systems:

- without Vitocontrol control panel

Vitotronic 100 (GC1/GC1B)

for constant boiler water temperature or outdoor reset mode in conjunction with an external control unit (BMS).

Vitotronic 300 (GW2/GW2B)

for modulating boiler water temperature with mixing valve control for a maximum of two heating circuits with mixing valve.

- with Vitocontrol control panel

Vitotronic 100 (GC1/GC1B)

and

Vitocontrol-S MW1/Vitotronic 300-K MW1B control panel

for outdoor reset mode and mixing valve control for a maximum of 2 heating circuits with mixing valve and additional Vitotronic 200-H, type HK1M/HK1B for additional up to 3 heating circuits with mixing valve.

For multi-boiler system (up to 4 boilers):

- without Vitocontrol control panel

Vitotronic 100 (GC1/GC1B) and LON module

for modulating boiler water temperature in conjunction with an external control unit (BMS).

- with Vitocontrol control panel

Vitotronic 100 (GC1/GC1B) and LON module

for modulating boiler water temperature for each boiler of the multi-boiler system and

Vitotronic 300-K MW1S/Vitotronic 300-K MW1B control panel

with Vitotronic 300-K MW1S/Vitotronic 300-K MW1B for multi-boiler system, outdoor reset mode and mixing valve control for a maximum of 2 heating circuits with mixing valve and additional Vitotronic 200-H, type HK1S/HK3S/HK1B for additional heating circuits with mixing valve.

For single or multiple-boiler installations:

Custom control panels

Custom control panels for residential or commercial applications are designed and manufactured by Viessmann to suit any customer's specific requirements. Custom control panels can have features such as pool heating, hot tub heating, snow melting, telephone tie-in, integration with Building Management Systems, as well as several other functions. Please inquire.

The control of the Vitorond 200, VD2 boiler can be mounted either on the left- or right-hand side of the boiler. Please specify control location at the time of order.

System Design Considerations

Burner calibration

With 2-stage and fully modulating burners, ensure that the chimney is compatible with the lower flue gas temperatures associated with partial load conditions set on the burner.

2-Stage burner

When used with the or Vitotronic control, the following minimum heating outputs are applicable to protect the boiler:

- 60% of outputs stated in the Technical Data table on page 5.

Fully modulating burner

The minimum boiler water temperature is:

- 140°F (60°C) with oil,
- 149°F (65°C) with natural gas.

Set the return temperature elevation system to maintain a minimum value of 127°F (53°C).

Venting

The Vitorond 200, VD2 boiler is approved as a Category I appliance and must be vented accordingly.



CAUTION

The Vitorond 200, VD2 boiler is not approved for side wall venting.

Chimney

For proper operation of the Vitorond 200, VD2 boiler, all products of combustion must be safely vented to the outdoors, while ensuring that flue gases do not cool prematurely.

It is critical that the chimney system be properly designed to handle the relatively cool flue gas temperatures produced by the Vitorond 200, VD2 boiler.

If the chimney system lacks sufficient insulation and/or the chimney diameter is too large, corrosive and damaging condensation will result due to flue gases cooling too quickly. If a calculated chimney diameter lies between two values, the larger diameter should be selected.

The chimney connection length between the boiler vent pipe collar and the chimney must be installed with insulation.

Vent pipe collar diameter does not automatically indicate vent/chimney size.

We recommend consulting a reputable chimney installer for advice in project-specific circumstances.

When installing the Vitorond 200, VD2 boiler, it is necessary to install a barometric draft regulator in the chimney/vent for proper operation of the boiler.

Install the barometric draft regulator within 5 to 7 ft. (1 ½ to 2 m) from the breeching outlet located at the rear of the boiler.

System Design Considerations *(continued)*

Barometric draft regulator type

For natural gas or propane applications, use a double-acting type.

For #2 fuel oil applications, use a single-acting type.

Barometric draft regulator diameter

The barometric draft regulator must be the same diameter opening as the chimney for which the vent is sized.

For example, a 14 in. (356 mm) chimney would require a 14 in. barometric draft regulator. Do not size the barometric draft regulator to the breeching outlet of the boiler, unless the chimney is also intended to be of that diameter.

IMPORTANT

The size of the flue gas outlet on the boiler does not automatically determine the horizontal breeching, or the actual chimney diameter. The chimney size must be designed for the actual boiler model and its input.

Venting option #2 (Category III)

The Vitorond 200 boiler is a Category III positive pressure non-condensing boiler.

Each boiler must be vented individually.

The vent system must be properly designed and suitable materials must be selected. The chimney must be gas tight.



Barometric draft regulator

Combustion air supply

The boiler must not be located in areas or rooms where chemicals containing chlorine, bromine, fluorine, or other corrosive chemicals are stored. Examples include refrigerants, bleach, paint, paint thinner, hair spray, cleaning solvents, water softener salt, etc.

The combustion air must not be contaminated with any amount of the above mentioned chemicals.

Boiler should never be installed in areas where excessive dust, high humidity, or risk of frost exist. Ensure adequate ventilation and supply of fresh combustion air.

Consult Viessmann with uncertainties in regard to a suitable boiler installation location.

This boiler/burner unit needs clean fresh air for safe operation. Provisions for combustion and ventilation air must be made at time of installation. For oil-fired boilers, use the "Installation Code for Oil Burning Equipment CAN/CSA-B139" (Canada), or NFPA 31 (USA).

For gas or propane installations, use the "Natural Gas Installation Code CAN/CSA-B149.1 or B149.2" (Canada), or "National Fuel Gas Code ANSI Z223.1" (USA), and/or provisions of local codes.

The sizing methods outlined in the above codes should be used when installing a round duct to supply combustion air from the outside.

Warranty

Our warranty does not cover damages resulting from the following:

- Corrosion caused by flue gas condensation due to low boiler water and/or return water temperatures.
- Operation with contaminated fill and supplementary feed water.

System layout

The boiler water temperature limit is factory set to 167°F (75°C).

The boiler water temperature limit can be increased by altering the adjustable high limit to increase the supply water temperature.

To minimize piping losses of the system, however, Viessmann recommends that the radiation and domestic hot water production in the system be designed for a 158°F (70°C) boiler supply water temperature.

System Design Considerations *(continued)*

Water quality

Treatment for boiler feed water should be considered in areas of known problems, such as where a high mineral content and hardness exist. In areas where freezing might occur, an antifreeze may be added to the system water to protect the system.

Please adhere to the specifications given by the antifreeze manufacturer. Do not use automotive silicate-based antifreeze. Please observe that an antifreeze/water mixture may require a backflow preventer within the automatic water feed and influence components such as diaphragm expansion tanks, radiation, etc.

A 40% antifreeze content will provide freeze-up protection to -10°F (-23°C). Do not use antifreeze other than specifically made for hot water heating systems. System also may contain components which might be negatively affected by antifreeze. Check total system frequently when filled with antifreeze.

Follow the instructions of antifreeze manufacturer.

Oxygen diffusion barrier underfloor tubing

The boiler warranty does not cover leaks resulting from corrosion caused by the use of underfloor plastic tubing without an oxygen diffusion barrier. Such systems must have the tubing without oxygen diffusion barrier separated from the boiler with a heat exchanger.

Viessmann recommends the use of underfloor plastic tubing with an oxygen diffusion barrier.

Burner Alternatives

Burner manufacturer

Weishaupt or Riello

Burner/Gas train approval

Standard approvals are CSA (for Canada) and UL (for U.S.). IRI and FM approved equipment is also available - please inquire.

Electrical requirements

Weishaupt WG, WL, L, RL, G, GL and WM-G(L) RGL Series burners listed on page 18 are available in 120 VAC single-phase, 208 VAC three-phase, 460 VAC three-phase, or 575 VAC three-phase, all in 60 Hz configuration. Size 7 burners are not available in 120 VAC single-phase configuration. It is generally acceptable to use voltages within ten percent of the supply voltage. Available voltage inside boiler room must be provided at time of order. Ensure appropriate disconnect means and overcurrent protection.

Natural gas pressure

Natural gas pressures and heating values as provided by the gas utilities vary greatly across North America. Select the appropriate gas train accordingly. Low pressure gas trains have a maximum input of 14 "w.c.; high pressure gas trains have a maximum pressure of 5 psig. Minimum gas pressures apply - please inquire. Gas pressures and heating values at site must be provided at time of order.

Factory pre-wired components

Custom factory pre-wiring by Viessmann ensures optimal functionality, compliance with regional requirements, and ease of installation in the field. Pricing provided by Viessmann includes all necessary hardware items such as junction panel, burner power supply, boiler door safety switch (where necessary), and all essential pressure switches, as well as interconnection with conduit between control and burner.

Electrical drawings provided upon product delivery.

Boiler/Burner start-up

Vitorond 200, VD2 boilers with Weishaupt burners require start-up by Viessmann.

Please inquire to obtain details regarding the necessary prerequisites of boiler/burner start-up procedures.

IMPORTANT

To minimize delivery lead times, please ensure that critical technical information is provided at time of order. Viessmann will not process an order without site-specific information regarding available voltage and gas pressure. In addition Viessmann recommends that gas pressure information be provided in writing by the local gas utility.

Standard Equipment

Burner Alternatives *(continued)*

Weishaupt Burners, Linkageless *1

Boiler model	VD2-	320	380	440	500	560	630	700	780	860	950	1080
No. 2 oil-fired 2-stage	Model	WL40			WM-L10/3			WM-L10/4		L7		
No. 2 oil-fired fully modulating	Model	WM-L10/2			WM-L10/3			RL5		RL7		
Natural gas-fired 2-stage	Model	WG40-LN			WM-G10/2	G10/3-LN		WM-G10/4		G7-LN		
Natural gas-fired fully modulating	Model	WG40-LN			WM-G10/2	G10/3-LN		WM-G10/4		G7-LN		
Propane gas-fired *2 2-stage	Model	WG40-LN			WM-G10/2	WM-G10/3		WM-G10/4		G7		
Propane gas-fired *2 fully modulating	Model	WG40-LN			WM-G10/2	WM-G10/3		WM-G10/4		G7		
Combination fully modulating NG, 2-stage oil	Model	WM-GL10/1	WM-GL10/2			WM-G10/3			WM-GL20/2			
Combination fully modulating NG, fully modulating oil	Model	WM-GL10/2				WM-GL10/3			WM-GL20/2			
Combination fully modulating NG, fully modulating L.P.	Model	WM-GL10/1	WM-GL10/2			WM-GL10/3			WM-GL10/4		WM-GL20/2	

*1 LN behind burner model no. indicates low NOx burner head is standard equipment.

*2 Please contact Viessmann to quote a propane burner gas train, where less than 14" w.c. gas pressure exists.

Riello Burners

Boiler model	VD2-	320	380	440	500	560	630	700	780	860	950	1080
No. 2 oil-fired 2-stage	Model	RL28/2	RL38/2	RL50/2			RL50/2		RL100/2			
No. 2 oil-fired fully modulating	Model	RL28/M	RL38/M	RL50/M			RL70/M		RL100/M			
Natural gas-fired fully modulating	Model	RS38/M		RS50/M		RS70/M		RS100/M				
Propane gas-fired fully modulating	Model	RS38/M		RS50/M		RS70/M		RS100/M				
Combination 2-stage NG/2-stage oil full mod. NG/2-stage oil	Model	RLS38		RLS50		-		-		-		
		-		-		RLS70		RLS100		RLS130		
Natural gas-fired fully modulating, low NOx	Model	RS45/M LN			RS68/M LN			RS120/M LN				

Note: The burner charts above have been selected based on a project elevation of <2000 ft. (610 m) ASL.

If the project elevation is >2000 ft. (610 m) ASL, please contact your Viessmann technical representative for assistance in selecting the boiler/burner combination.

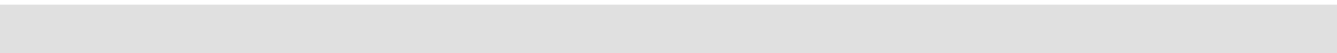

Quick Reference

°C	°F
-40	-40
-35	-31
-25	-13
-20	-4
-18	0
-16	+3
-14	+7
-12	+10
-10	+14
-9	+16
-8	+18
-7	+19
-6	+21
-5	+23
-4	+25
-3	+27
-2	+28
-1	+30
0	+32
+1	+34
+2	+36
+3	+37
+4	+39
+5	+41
+6	+43
+7	+45
+8	+46
+9	+48
+10	+50
+12	+54
+14	+57
+16	+61
+18	+64
+20	+68
+25	+77
+30	+86
+35	+95
+40	+104
+50	+122
+60	+140
+70	+158
+80	+176
+90	+194
+100	+212
+110	+230

Viessmann Manufacturing Company Inc.
 750 McMurray Road
 Waterloo, Ontario • N2V 2G5 • Canada
TechInfo Line 1-888-484-8643
 1-800-387-7373 • Fax (519) 885-0887
 www.viessmann.ca • info@viessmann.ca

Viessmann Manufacturing Company (U.S.) Inc.
 45 Access Road
 Warwick, Rhode Island • 02886 • USA
TechInfo Line 1-888-484-8643
 1-800-288-0667 • Fax (401) 732-0590
 www.viessmann-us.com • info@viessmann-us.com

Printed on environmentally friendly
 (recycled and recyclable) paper.



Technical information subject to change without notice.