

# Service and Maintenance Instructions

for use by engineers and heating contractors

# VIESSMANN®

## Vitoflex 300-RF 150, 220, 300, 400 and 540

Wood-fired Boiler

Output range: RF 150 154 - 512 MBH (45- 150 kW)  
RF 220 205 - 751 MBH (60- 220 kW)  
RF 300 273 - 1024 MBH (80- 300 kW)  
RF 400 341 - 1365 MBH (100- 400 kW)  
RF 540 478 - 1843 MBH (140- 540W kW)



## Vitoflex 300-RF



### **WARNING**

If the information in this manual is not followed exactly, a fire or explosion may result causing property damage, personal injury or loss of life.

Do not store or use gasoline or other flammable fluids in the vicinity of this or any other appliance.

#### WHAT TO DO IF YOU SMELL FLUE GAS

- Deactivate heating equipment
- Open windows and doors.
- Inform your heating contractor

### **WARNING**

Improper installation, adjustment and/or operation could cause carbon monoxide poisoning resulting in injury or loss of life. This product must be installed and serviced by a professional service technician who is experienced and qualified in hot water boiler installation and wood fuel combustion.



*Product may not be exactly as shown*

### **IMPORTANT**

**Read and save these instructions for future reference.**

## Safety, Installation and Warranty Requirements

Please ensure that these instructions are read and understood before commencing service and/or maintenance. Failure to comply with the instructions listed below and details printed in this manual can cause product/property damage, severe personal injury, and/or loss of life. Ensure all requirements below are understood and fulfilled (including detailed information found in manual subsections).

### ■ Product documentation

Read all applicable documentation before commencing installation. Store documentation near boiler in a readily accessible location for reference in the future by service personnel.

►For a listing of applicable literature, please see section entitled "Important Regulatory and Safety Requirements".



### ■ Warranty

Information contained in this and related product documentation must be read and followed. Failure to do so renders the warranty null and void.



### ■ Licensed professional heating contractor

The installation, adjustment, service and maintenance of this equipment must be performed by a licensed professional heating contractor.

►Please see section entitled "Important Regulatory and Installation Requirements".

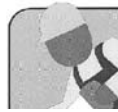

### ■ Contaminated air

Air contaminated by chemicals can cause by-products in the combustion process, which are poisonous to inhabitants and destructive to Viessmann equipment.

►For a listing of chemicals which cannot be stored in or near the boiler room, please see subsection entitled "Mechanical Room".



### ■ Advice to owner

Once the installation work is complete, the heating contractor must familiarize the system operator/ultimate owner with all equipment, as well as safety precautions/requirements, shutdown procedure, and the need for professional service.

### ■ Carbon monoxide

Improper installation, adjustment, service and/or maintenance can cause flue products to flow into living space. Flue products contain poisonous carbon monoxide gas.

►For information pertaining to the proper installation, adjustment, service and maintenance of this equipment to avoid formation of carbon monoxide, refer to the installation and operating instructions.



### ■ Fresh air

This equipment requires fresh air for safe operation and must be installed ensuring provisions for adequate combustion and ventilation air exist.

►For information pertaining to the fresh air requirements of this product, please see subsection entitled "Combustion Air Supply".

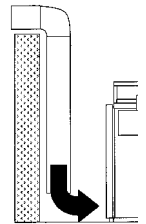

### ■ Equipment venting

Never operate the boiler without an installed venting system. An improper venting system can cause carbon monoxide poisoning.

►For information pertaining to venting and chimney requirements, refer to the installation and operating instructions. All products of combustion must be safely vented to the outdoors.



## ⚠ WARNING

Installers must follow local regulations with respect to installation of carbon monoxide detectors. Follow manufacturer's maintenance schedule of the boiler contained in the section "Cleaning and Maintenance".

## About these Instructions

 Take note of all symbols and notations intended to draw attention to potential hazards or important product information. These include "WARNING", "CAUTION", and "IMPORTANT". See below.

 <b>WARNING</b>
Warnings draw your attention to the presence of potential hazards or important product information.

► Indicates an imminently hazardous situation which, if not avoided, could result in death, serious injury or substantial product/property damage.

 <b>CAUTION</b>
Cautions draw your attention to the presence of potential hazards or important product information.

► Indicates an imminently hazardous situation which, if not avoided, may result in minor injury or product / property damage.

<b>IMPORTANT</b>
------------------

► Helpful hints for installation, operation or maintenance which pertain to the product.



► This symbol indicates to note additional information



► This symbol indicates that other instructions must be referenced.

**Note:** Viessmann Manufacturing Company Inc. reserves the right to make product changes or updates without notice and will not be held liable for errors or omissions in the product literature.

	Page
<b>Introduction</b>	
	<b>Safety, Installation and Warranty Requirements.....2</b>
	<b>About these Instructions.....3</b>
<b>General Information</b>	
	<b>Product Information.....5</b>
	<b>Important Regulatory and Installation Requirements .....6</b>
<b>Safety</b>	
	<b>Safety Instructions.....8</b>
	<b>Carbon Monoxide.....9</b>
	<b>Extreme Weather Conditions.....10</b>
	<b>Hazardous Material.....11</b>
	<b>Mechanical Room.....12</b>
	<b>Combustion Air Supply.....13</b>
<b>Maintenance</b>	
	<b>Components of the Biomass Boiler.....14</b>
	<b>Cleaning.....15</b>
	Boiler.....15
	Heat exchanger displacement rods.....16
	Installing the displacement rods.....16
	Removing the displacement rods.....16
	Flue gas cyclone (optional).....17
	Pneumatic cleaning system (optional).....17
	<b>Feed systems.....18</b>
	<b>Shutdown.....19</b>
	Boiler.....19
	Extraction and conveyance systems.....19
	Control system.....19
	Replacing the buffer battery.....19
	Ash disposal.....19
	Disposal of the boiler.....19
	Instructions regarding removal.....19
	Waste disposal.....19
<b>Troubleshooting</b>	
	<b>Performance Problems.....20</b>
	<b>Grate Drive Mechanics Jams.....21</b>
	<b>Checking for increased Wear of Fireclay.....22</b>
	<b>Checking the Inside of the Boiler Door.....23</b>
	<b>Checking the Oxygen Control System.....24</b>
	<b>Balancing the Oxygen Sensor.....25</b>
	<b>Heating System Faults.....26</b>
	<b>Loader System Faults.....27</b>

**Product Information**

Viessmann solid-fuel boiler can only be installed and serviced by qualified trained personnel.

Steel wood-fired hot water heating boiler.

For operation primarily with modulating boiler water temperatures in closed loop forced circulation hot water heating systems. Under certain conditions, open loop systems may also be considered. Contact Viessmann for details.

Maximum allowable working pressure (water)...30 or 60 psi

Maximum water temperature...250°F (120°C) (closed loop)

Maximum boiler temperature.....210°F (99°C) (open loop)

This boiler does not require a flow switch.

 **WARNING**

**Exposing the boiler to pressures and temperatures in excess of those listed will result in damages and will render the warranty null and void.**

**Codes and standards**

CSA B366.1-M91

Solid Fuel Fired Central Heating Appliances

CSA C.22.2#3-M88 (R2004)

Electrical Features of Fuel Burning Equipment

UL2523

Solid Fuel-Fired Hydronic Heating Appliances, Water Heaters and Boilers

CSA B365-10

Installation Code for Solid Fuel Burning Appliances and Equipment

ASME section IV boilers and pressure vessels

## Important Regulatory and Installation Requirements

Please carefully read this manual prior to attempting service and maintenance. Any warranty is null and void if these instructions are not followed.

For information regarding other Viessmann System Technology componentry, please reference documentation of the respective product.

We offer frequent installation and service seminars to familiarize our partners with our products. Please inquire.

### Working on the equipment

The installation, adjustment, service, and maintenance of this boiler must be done by a licensed professional heating contractor who is qualified and experienced in the installation, service, and maintenance of hot water boilers.

Ensure main power supply to equipment, the heating system, and all external controls have been deactivated. Take precautions to avoid accidental activation of power during service work.

- ▶ *The completeness and functionality of field supplied electrical controls and components must be verified by the heating contractor. These include low-water cut-offs, flow switches (if used), staging controls, pumps, motorized valves, air vents, thermostats, etc.*



### CAUTION

**RISK OF INJURY:** Shut the system off before starting any cleaning. Be absolutely sure to wear protective gloves, protective eyewear if required and use the cleaning tools that come with the system (danger of blow-ups, burns and getting crushed)!

### Technical literature

Literature applicable to all aspects of the Vitoflex 300-RF wood-fired boiler:

- Installation and Operating Instructions
- Service and Maintenance Instructions
- Field Wiring Diagram

- ▶ *Leave all literature at the installation site and advise the system operator/ultimate owner where the literature can be found. Contact Viessmann for additional copies.*
- ▶ *This product comes with several safety instruction labels attached. Do not remove! Contact Viessmann immediately if replacement labels are required.*

**Important Regulatory and Installation Requirements** *(continued)*

**Regular maintenance and service**

The entire heating system must be cleaned and serviced on a regular basis by a qualified contractor or service agency to ensure reliable, energy-efficient, and environmentally friendly operation.

The build-up of soot on the heat exchanger raises the flue gas temperature and reduces efficiency.

**! WARNING**

The boiler must not be located in areas or rooms where chemicals are stored or aggressive vapors from (i.e. bleach, hair spray, methyl chloride, carbon tetrachloride or perchloroethylene) or high dust levels or humidity levels are present. Heat exchanger corrosion might occur and reduce the lifetime of the boiler significantly. If above criteria are not properly observed and boiler damage results, any warranty on the complete boiler and related components will be null and void.

**IMPORTANT**

Keep boiler and boiler room clear and free of combustible materials, gasoline and other flammable vapors and liquids. Do not obstruct the flow of combustion and ventilation air. All inspection, maintenance and service must be performed by a qualified heating contractor.

**! WARNING**

Improper installation, adjustment, service or maintenance can cause flue products to flow into living space. Flue products contain poisonous carbon monoxide gas, which can cause nausea or asphyxiation resulting in severe personal injury or loss of life.

**! WARNING**

Service and maintenance can only be performed by a qualified heating contractor.

**Important to know**

Do not use this boiler if any part has been under, or exposed to, water. Immediately call a qualified heating contractor to inspect the boiler and to replace any part of the control system, which has been under or exposed to water.

## Safety Instructions

### IMPORTANT

The local building codes and regulations must be followed by the heating contractor.

### IMPORTANT



Please refer to the Installation and Operating Instructions for installation, commissioning and technical specification information. The "Installation and Operating Instructions" contain the necessary safety and national/local code requirements which, if not followed exactly, may lead to property damage, personal injuries and/or death.

### Important Information

#### Safety instructions

When carrying out work on the heating system, such as cleaning and maintenance, wear appropriate protective equipment when required.

There is a danger of getting injured through: burning, knocking against corners and edges, crushing in moving parts and noise.

Power supply: 120V or 240V/1/ and 208V/3/ 60Hz  
In case of an emergency, the Vitoflex 300-RF can be disconnected from the electrical power supply at all the leads by the main switch on the control cabinet.

If you notice fire coming from the appliance, call the fire department immediately!  
DO NOT attempt to extinguish the fire unless qualified to do so.

### WARNING

Fire causes a risk of burns and explosion!

- Shut down the boiler
- Close fuel shut-off valves
- Use a tested fire extinguisher, class ABC.

Doors: for safety keep firing and ash pit doors tightly closed

### CAUTION

#### FIRE HAZARD:

The boiler must **NEVER** be operated with the doors open!  
Any burning bits that escape could start a fire.

#### RISK OF INJURY:

If the doors are open during operation, sparks or flames could leap out.

Equipment for dissipating excess heat: a competent specialist should examine the operational reliability of the thermal safety flush valve annually. The safety heat exchanger must not by any means be used as an operational heat exchanger.

Seals: for the functioning and controllability of the boiler, it is important that no unwanted air can enter unchecked through leaks.

The doors and lids have to shut tight - any damaged seals must be replaced immediately. Tighten the retaining screws and handles well.

Operation, cleaning and maintenance: bear in mind that even the best product can only fulfill its functions well, doing so for a long time and free of malfunctions, if operated and maintained properly.

### IMPORTANT

Compliance with the "Cleaning" section is mandatory!



## Carbon Monoxide

### Carbon monoxide

The U.S. Consumer Product Safety Commission strongly recommends the installation of carbon monoxide detectors in buildings in which wood-burning equipment is installed. Carbon monoxide (CO) is a colorless, odorless gas, which may be produced during incomplete combustion of fuel and/or when the flame does not receive an adequate supply of combustion air. Carbon monoxide can cause severe personal injury or loss of life.

Therefore, carbon monoxide detectors that are in compliance with a nationally recognized standard (e.g. ANSI/UL 2034-2002, CSA 6.19-01) should be installed and maintained in buildings that contain wood-burning equipment.

**Note:** Viessmann does not test any detectors and makes no representation regarding any brand or type of detector.

### For safe operation

We recommend that you frequently:

- Check for debris which could obstruct the flow of flue gases. The vent or chimney must not be blocked. A blocked or partially blocked vent or chimney can cause flue gases to leak into the structure. Flue gases leaking into the house can cause injury or death. Blocked or partially blocked chimneys must have the blockage removed by a qualified heating contractor.
- Check pressure gage for correct system (water) pressure. Check for water on the floor from the discharge pipe of the pressure relief valve or any other pipe, pipe joint, valve or air vent.
- Check for moisture, water, or appearance of rust on the flue gas pipes, their joints as well as vent dampers, or side wall vent terminals (if so equipped).
- Ensure that nothing is obstructing the flow of combustion and ventilation air and no chemicals, garbage, gasoline, combustible materials, flammable vapors and liquids are stored (not even temporarily) in the vicinity of the boiler.
- DO NOT allow unsupervised children near the boiler.

Service/inspection of the boiler and the system must be performed on a regular basis. Maintenance, service and cleaning are specified in the section "Maintenance".

Before the heating season begins, it is recommended that the boiler be serviced by a qualified heating contractor.

### WARNING

**Improper installation, adjustment, service or maintenance can cause flue products to flow into living space. Flue products contain poisonous carbon monoxide gas, which can cause nausea or asphyxiation resulting in severe personal injury or loss of life.**

### WARNING

**The operator/ultimate owner is required to have the heating boiler and controls checked, as a minimum once per year, by the original installer or by a competent heating contractor familiar with the equipment. Defects must be corrected immediately.**

## Extreme Weather Conditions

### Frozen water pipe hazard

Your heating boiler is designed to provide a warm and comfortable living environment. It is NOT designed to ensure against freezing of water pipes. The boiler is equipped with several safety devices that are designed to shut down the boiler and to prevent it from restarting in the event of various unsafe conditions.

If your boiler remains off for an extended period of time during cold weather, water pipes may freeze and burst, resulting in extensive water damage and conditions in which mold could grow. Certain molds are known to cause respiratory problems, as well as to pose other serious health risks. In case of water damage, immediate measures should be taken to dry out affected areas as quickly as possible to prevent mold from developing.



### WARNING

**As there are no user-serviceable parts on the boiler, or control, the end-user must not perform service activities of any kind on system components. Failure to heed this warning can cause property damage, severe personal injury or loss of life.**

If the building will be unattended for an extended period of time during cold weather, you should...

Shut off the water supply to the building, drain the water pipes and add antifreeze for potable water to drain traps and toilet tanks. Open faucets where appropriate.

or...

Have someone check the building frequently during cold weather and call a qualified service agency if required.

or...

Install a reliable remote temperature sensor that will notify somebody of freezing conditions within the building.

## Hazardous Material

### Fiberglass wool and ceramic fiber materials

#### WARNING

Inhaling of fiberglass wool and/or ceramic fiber materials is a possible cancer hazard. These materials can also cause respiratory, skin and eye irritation.

The state of California has listed the airborne fibers of these materials as a possible cancer hazard through inhalation. When handling these materials, special care must be applied.

#### WARNING

Appliance materials of construction, products of combustion and the fuel contain alumina, silica, heavy metals, carbon monoxide, nitrogen oxides, aldehydes and/or other toxic or harmful substances which can cause serious injury or loss of life and which are known to the State of California to cause cancer, birth defects and other reproductive harm. Always use proper safety clothing, respirators and equipment when servicing or working nearby the appliance.

#### First aid measures

- If eye contact occurs, flush eyes with water to remove dust. If symptoms persist, seek medical attention.
- If skin contact occurs, wash affected areas gently with soap and warm water after handling.

#### Suppliers of ceramic fiber products recommend the following first aid measures:

- Respiratory tract (nose and throat) irritation: If respiratory tract irritation develops, move the person to a dust free location.
- Eye irritation: If eyes become irritated, flush immediately with large amounts of lukewarm water for at least 15 minutes. Eyelids should be held away from the eyeball to ensure thorough rinsing. Do not rub eyes.
- Skin irritation: If skin becomes irritated, remove soiled clothing. Do not rub or scratch exposed skin. Wash area of contact thoroughly with soap and water. Using a skin cream or lotion after washing may be helpful.
- Gastrointestinal irritation: If gastrointestinal tract irritation develops, move the person to a dust free environment.

#### Suppliers of fiberglass wool products recommend the following precautions be taken when handling these materials:

- Avoid breathing fiberglass dust and contact with skin and eyes.
- Use NIOSH approved dust/mist respirator.
- Wear long-sleeved, loose fitting clothing, gloves and eye protection.
- Wash work clothes separately from other clothing. Rinse washer thoroughly.
- Operations such as sawing, blowing, tear-out and spraying may generate airborne fiber concentration requiring additional protection.

## Mechanical Room

No combustible materials may be stored in the heating room. The heating boiler may only be set up on a fire-resistant and temperature-resistant floor. No temperature-sensitive pipes or lines may be installed in the floor beneath the heating boiler.

A sufficient supply of fresh air must be provided directly from outdoors into the heating room. Induced ventilation is necessary for heating rooms that are confined or enclosed.

See "Installation and Operating Instructions" for more details.

The temperature in the heating room must not exceed 104°F (40°C) while the system is in operation (in the area approx. 3 ft. (1 m) away from the boiler). The temperature in the heating room must not fall below 50°F (10°C) while the system is in operation (measured at the inner side of exterior walls).

### IMPORTANT

**Always follow the most up-to-date local, municipal and building regulations and codes.**

#### Mechanical room conditions



### WARNING

**Incorrect ambient conditions can lead to damage to the heating system and put safe operation at risk.**

Prevent the air from becoming contaminated by homogenate hydrocarbons (e.g. as contained in paints solvents or cleaning fluids) and excessive dust (e.g. through grinding or polishing work). Combustion air for the heating process, and ventilation of the boiler room must be free of corrosive contaminants. To that end, any boiler must be installed in an area that has no chemical exposure. The list to the right indicates the main, currently known sources.

Avoid continuously high levels of humidity (e.g. through frequent drying of laundry).

Never close existing ventilation openings.

### IMPORTANT

**Components which are not tested with the heating system may damage the heating system or affect its functions. Installation or replacement may only be carried out by a qualified heating contractor.**

#### Sources of combustion and ventilation air contaminants

Areas likely to contain contaminants:

- New building construction
- Swimming pools
- Remodeling areas, hobby rooms
- Garages with workshops
- Furniture refinishing areas
- Dry cleaning/laundry areas and establishments
- Auto body shops
- Refrigeration repair shops
- Metal fabrication plants
- Plastic manufacturing plants
- Photo processing plants
- Beauty salons

Products containing contaminants:

- Chlorine-type bleaches, detergents and cleaning solvents found in household laundry rooms
- Paint and varnish removers
- Hydrochloric acid, muriatic acid
- Chlorine-based swimming pool chemicals
- Spray cans containing chlorofluorocarbons
- Chlorinated waxes and cleaners
- Cements and glues
- Refrigerant leaks
- Calcium chloride used for thawing
- Sodium chloride used for water softening salt
- Permanent wave solutions
- Adhesives used to fasten building products and other similar item
- Antistatic fabric softeners used in clothes dryers

## Combustion Air Supply

### Codes

Provision for combustion and ventilation air must be made in accordance with applicable local codes.

In the absence of local codes, use:

CSA B365-10, Installation Code for Solid Fuel Burning Appliances and Equipment.

Always use latest edition codes.



### WARNING

Failure to provide an adequate supply of fresh combustion air can cause poisonous flue gases to enter living space. Flue gases entering living space can cause carbon monoxide poisoning which can result in severe personal injury or loss of life.



### WARNING

Never cover the boiler or store debris or other materials near the boiler, or in any way block the flow of adequate fresh air to the boiler. Never cover the combustion air opening. Advise system operator/ultimate owner accordingly.



### WARNING

The boiler must not be located in areas or rooms where chemicals are stored, or aggressive vapors (i.e. bleach, hair spray, methyl chloride, carbon tetrachloride or perchloroethylene) or high dust levels or humidity levels are present. Heat exchanger corrosion might occur and reduce the lifetime of the boiler significantly. If above criteria are not properly observed and boiler damage results, any warranty on the complete boiler and related components will be null and void.

### General

This equipment requires fresh air for safe operation.

The boiler location must never be under negative pressure. Exhaust fans, attic fans, or dryer fans may cause air to be exhausted at a rate higher than air can enter the structure for safe combustion.

The heating contractor shall ensure all of the following requirements are met:

- An adequate supply of combustion air must be available to ensure proper combustion.
- Ambient air temperatures must be maintained within safe operating limits.
- When a damper is provided in any opening intended to admit combustion air into the room within which the appliance is installed, the damper shall be interlocked to prevent any boiler from starting before the damper is fully open.
- Each duct used to convey air from the outdoors shall have:
  1. a cross-sectional area throughout its length at least equal to the free area of the inlet and outlet openings which it connects,
  2. making a provision for outside combustion air, the intake shall not be less than 1 ft. (0.3 m) above the anticipated snow level for the location.
- The heating contractor must check with local authorities (municipal building department) for combustion air requirements particular to the area.

See "Installation and Operating Instructions" for more details.

## Components of the Biomass Boiler

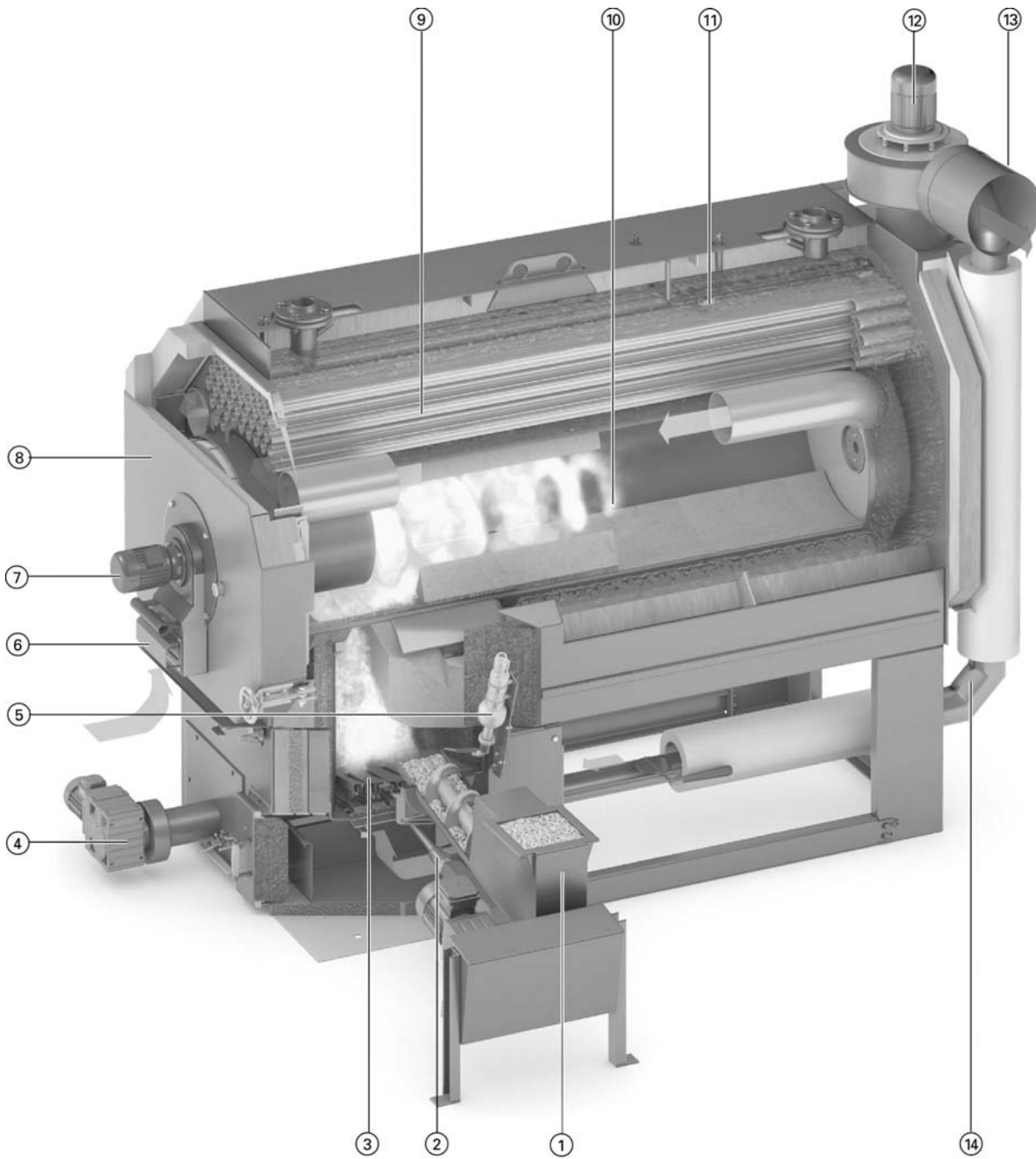

- ① In-feed auger with isolating layer
- ② Drive for moving grate
- ③ Moving grate
- ④ Drive for automatic de-ashing system (optional)
- ⑤ Igniter
- ⑥ Controlled combustion air supply system
- ⑦ Rotary blower (Viessmann-patented)

- ⑧ Boiler door
- ⑨ Heat exchanger
- ⑩ Rotary combustion chamber (Viessmann-patented)
- ⑪ Safety heat exchanger for thermal safety flush valve
- ⑫ Frequency-controlled flue gas exhaust blower
- ⑬ Pneumatic cleaning system (optional)
- ⑭ Flue gas recirculation pipe

# Cleaning

## Boiler

The heat exchanger, flue gas pipe, and chimney must be cleaned regularly to remove accumulated creosote and ash. Ensure that the heat exchanger, flue gas pipe, and chimney are cleaned at the end of the heating season to minimize corrosion during the summer months. The appliance, flue gas pipe, and chimney must be in good condition.

Regular cleaning and maintenance of the boiler system is of the utmost importance to assure trouble-free operation and to obtain the largest possible output at the best efficiency.

The cleaning intervals listed here are for wood chip fuel material with clinging bark with 0.8% ash content. The cleaning intervals may vary, depending on the fuel, the amount of fine matter and the operating conditions.

With pneumatic cleaning system, after approx. 600 operating hours; without pneumatic cleaning system, after approx. 300 operating hours:

Open the boiler door and clean all heat exchanger with a wire cleaning brush. Use the ash rake to carefully draw the fly ash lying in the rotary combustion chamber to the front.

After approx. 1000 operating hours: Disconnect the power from the flue gas exhaust blower, loosen the butterfly nuts, pull out the motor with impeller and clean the assembly with a broom or wire brush.

**IMPORTANT**  
With pneumatic cleaning system, disconnect the compressed air line before opening the boiler door – danger of injury!

**CAUTION**  
DANGER OF INJURY – be absolutely sure to turn OFF the main switch.

After approx. 300 operating hours: Open the lid across the in-feed auger and clear the slots in the grate.

**CAUTION**  
RISK OF INJURY: Shut the system off before starting any cleaning. Be absolutely sure to wear protective gloves, protective eyewear if required and use the cleaning tools that come with the system (danger of blow-ups, burns and getting crushed)!

Check the level of the ash bin regularly and empty the bin before it is completely full.

**IMPORTANT**  
NEVER operate the boiler without the ash bin.

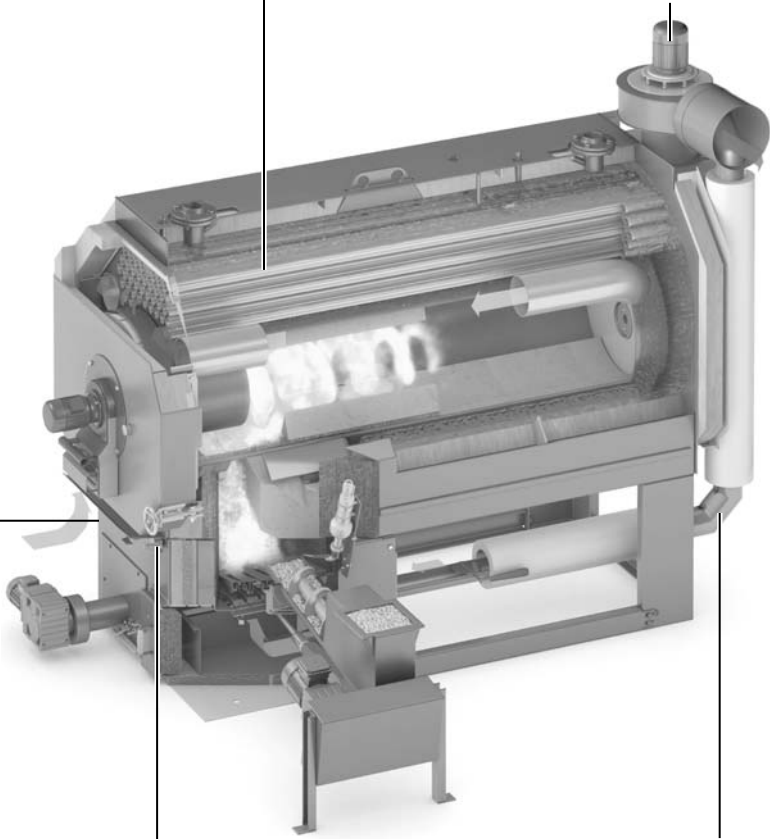

After approx. 1000 operating hours: Clean the recirculated flue gas line.

After approx. 300 operating hours: Loosen and clean the light barriers and the inspection windows on the combustion chamber. Remove dust and ash in the openings.

**Cleaning** *(continued)***Heat exchanger displacement rods**

The displacement rods improve the heat transmission in the heat exchanger and reduce the temperature of the exhaust gas, thus improving the efficiency of the heating system. They have to be taken out to clean the heat exchanger and put back in after cleaning.

**Installing the displacement rods**

Insert the displacement rods into the heat exchanger with the thick end first. Push until they are flush with the edge of the tube. Tolerance  $\pm 1/4$ " (5 mm).

**Removing the displacement rods**

Remove the displacement rods with a pair of pliers, as shown above. The heat exchanger should be cleaned at the intervals prescribed so that performance and efficiency are maintained and the displacement rods can be easily removed.

**⚠ CAUTION**

**RISK OF INJURY:** Shut the system off before starting any cleaning. Be absolutely sure to wear protective gloves, protective eyewear if required and use the cleaning tools that come with the system (danger of blow-ups, burns and getting crushed)!



## Cleaning *(continued)*

### Flue gas cyclone (optional)

The flue gas cyclone minimizes dust emissions and is designed as a multi-cyclone with an axial function. The cyclone is completely insulated and provided with a total of three lids for cleaning. The untreated exhaust flue gas chamber is cleaned via the cleaning lid on the side. The clean exhaust flue gas chamber is cleaned via the top or rear cleaning lid (unused blower connection).

The ash container, which is provided with a trolley, connects to the cyclone by quick-action fasteners and easily moves out for emptying. The flue gas exhaust blower can be mounted either on top or on the side, as desired.

After approx. 1000 operating hours:  
Disconnect the power, unscrew the butterfly nuts, pull out the motor with impeller and clean the assembly with a broom or wire brush.

After every cleaning of the boiler heat exchanger:  
Open the side lids and clean the guide blades of the cyclone with a hand-brush.

Check the level of the ash container regularly and empty the bin before it is completely full.

### CAUTION

**RISK OF INJURY:** Shut the system off before starting any cleaning. Be absolutely sure to wear protective gloves, protective eyewear if required and use the cleaning tools that come with the system (danger of blow-ups, burns and getting crushed)!

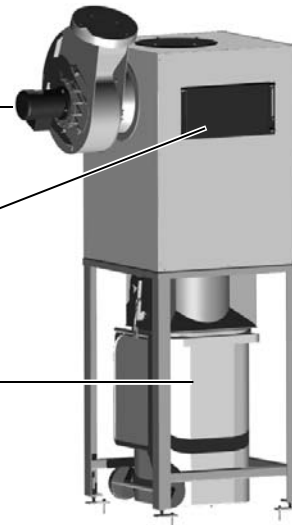

### IMPORTANT

**Never operate the boiler without an ash bin!**

### Pneumatic cleaning system (optional)

- Operation and maintenance of the air compressor (optional) according to the manual that comes with the system.
- For a field supplied air compressor, the compressor has to be suited for continuous operation or be secured against continuous operation (e.g. timer for limiting running time).
- Continuous operation of the compressor indicates leakage in the air system. Check air supply line and valves for leakage.

Regularly drain condensation water in the compressed air distribution bar.



## Feed Systems

When storage facilities for wood are required the wood should be kept at least 5 ft. (1.5 m) from the heating appliance.

All geared motors on the feed systems are maintenance-free.

- A change of lubricant and/or oil is recommended every 20,000 operating hours or every three years.
- Re-lubricate flange bearings and other lubricating points regularly with lithium soap grease.
- Check chain drives for wear and if necessary, tighten them up and lubricate with chain oil.
- Check all bolts for tightness.
- Once a year check the extraction components in the silo and/or bunker for damage and soiling. Remove any foreign matter.

Funnel extraction system (AP/APS):

Lubricate the gasket between the extraction casing and the geared motor and universal joint for the auger.

If a fuel hopper is installed, do not alter equipment in any way. May be connected to an existing boiler or solar system.

### IMPORTANT

Never use inflammable lubricants!

### CAUTION

**RISK OF INJURY:** Shut the system off before starting any cleaning. Be absolutely sure to wear protective gloves, protective eyewear if required and use the cleaning tools that come with the system (danger of blow-ups, burns and getting crushed)!

**Note:** Viessmann recommends the installation of carbon monoxide detector(s) inside the fuel storage area.

### IMPORTANT

The fuel storage area/room must be designed, operated and maintained to national, provincial and local codes and requirements.

### WARNING

The wood chip/pellet storage room must be adequately and permanently ventilated. Ensure the door or latches are securely locked open during presence in the room. No smoking, fires or open flames are permitted.

## Shutdown

### Boiler

Heat exchanger:

- When the Vitoflex 300-RF is not in operation for a long period (such as for summer breaks), be sure to carefully clean the heat exchanger with a steel brush as required.
- If the heating room is moist or there is any other atmosphere that promotes corrosion (e.g. poor ventilation, residual enamel near the heating room, etc.), spray the heat exchanger with biodiesel after cleaning.
- If there is a danger of frost, empty the heating system or add antifreeze.

### Extraction and conveyance systems

When the Vitoflex 300-RF is not in operation for a long period (such as for summer breaks), it is recommended to empty the fuel extraction and conveyance system of all fuel to avoid corrosion of the equipment and decay of the wood fuel. Refill with new fuel after checking the system and before the boiler startup.

### Control system

Even when the Vitoflex 300-RF is not in operation for long periods, the power supply to the control system should not be interrupted (do not turn off the main switch).

- The "intermittent control system" switches on the boiler pump for five seconds every 24 hours. This prevents the pump from jamming during long stand stills and prevents expensive repairs.
- Prevent the formation of condensation in the oxygen sensor.
- Extend the service life of the buffer battery.

### Replacing the buffer battery

The buffer battery is built in beneath the removable lid on the control module (type Panasonic Lithium BR2330). It is for buffering the time, date and settings.

**Note:** The battery needs replacing every five years.  
DO NOT disconnect the main power or turn off the main switch while changing the battery.

### Ash disposal

- Ashes should be stored in covered metal containers on non-combustible floors away from combustible material.
- Comply with customary laws and local regulations on ash disposal.

### Disposal of the boiler

- Switch off the Vitoflex 300-RF by pressing the F1 button. When the burn-out has taken place and the boiler has cooled down, turn off the main switch.
- Disconnect the power supply to the control cabinet.



## CAUTION

### DANGEROUS VOLTAGE!

Only a licensed electrician is allowed to disconnect and dismantle the connection to the electrical network.

- Close the supply and return valves.
- Open the drain valve on the bottom of the boiler and drain the water.

## IMPORTANT

Only a qualified heating contractor may drain the boiler and dismantle the connections to the heating system.

- Disconnect the supply pipe and return pipe from the boiler.

### Instructions regarding removal

Personnel removing equipment must be aware of the risks and use suitable safety precautions.

### Waste disposal

- Comply with customary laws and local regulations on waste disposal.
- Contact a disposal company to dispose and recycle waste in an environmental friendly way.

# Performance Problems

The boiler does not provide its original performance.

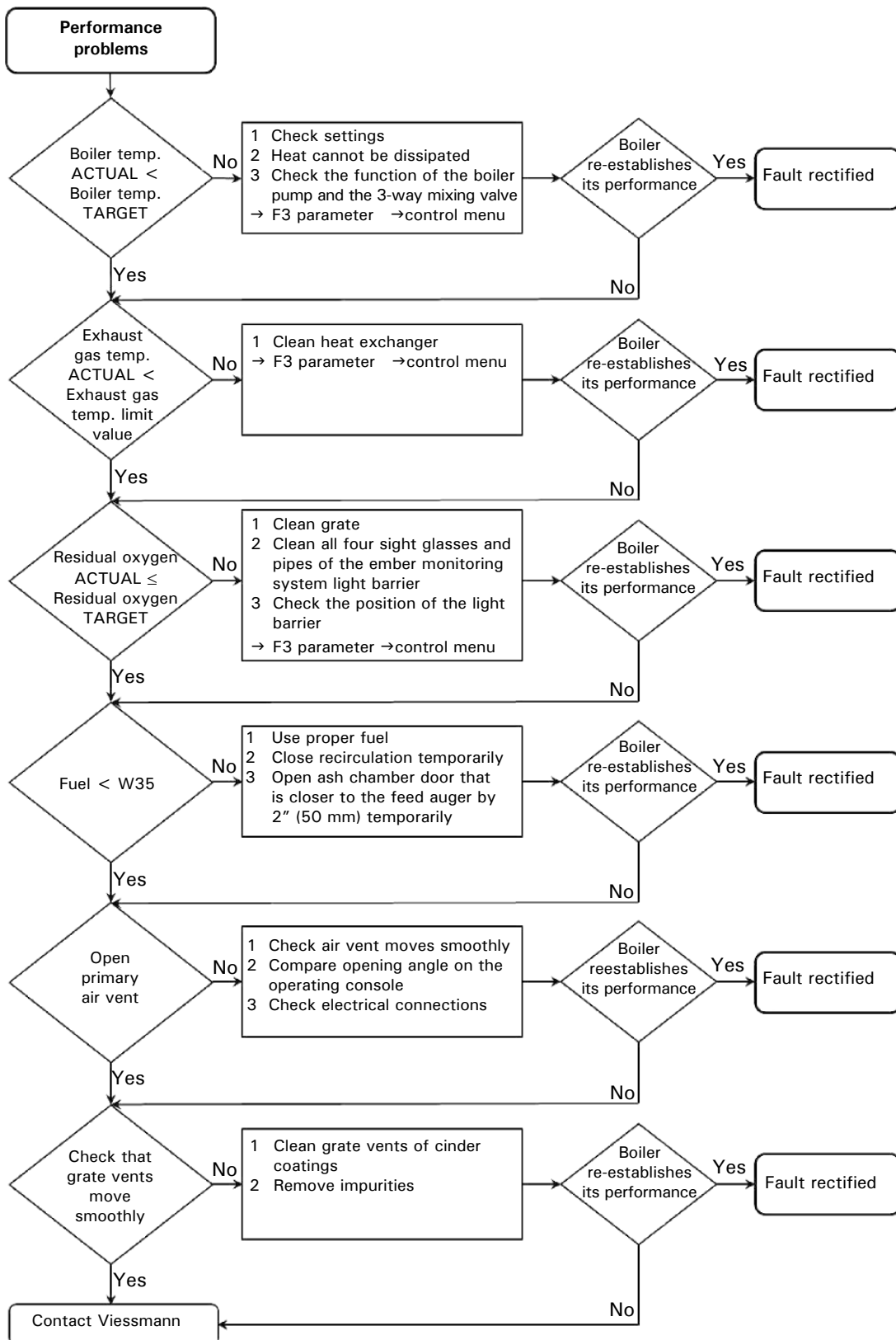

## Grate Drive Mechanics Jams

Grate drive mechanics are no longer running causing cinders to accumulate on the grate.

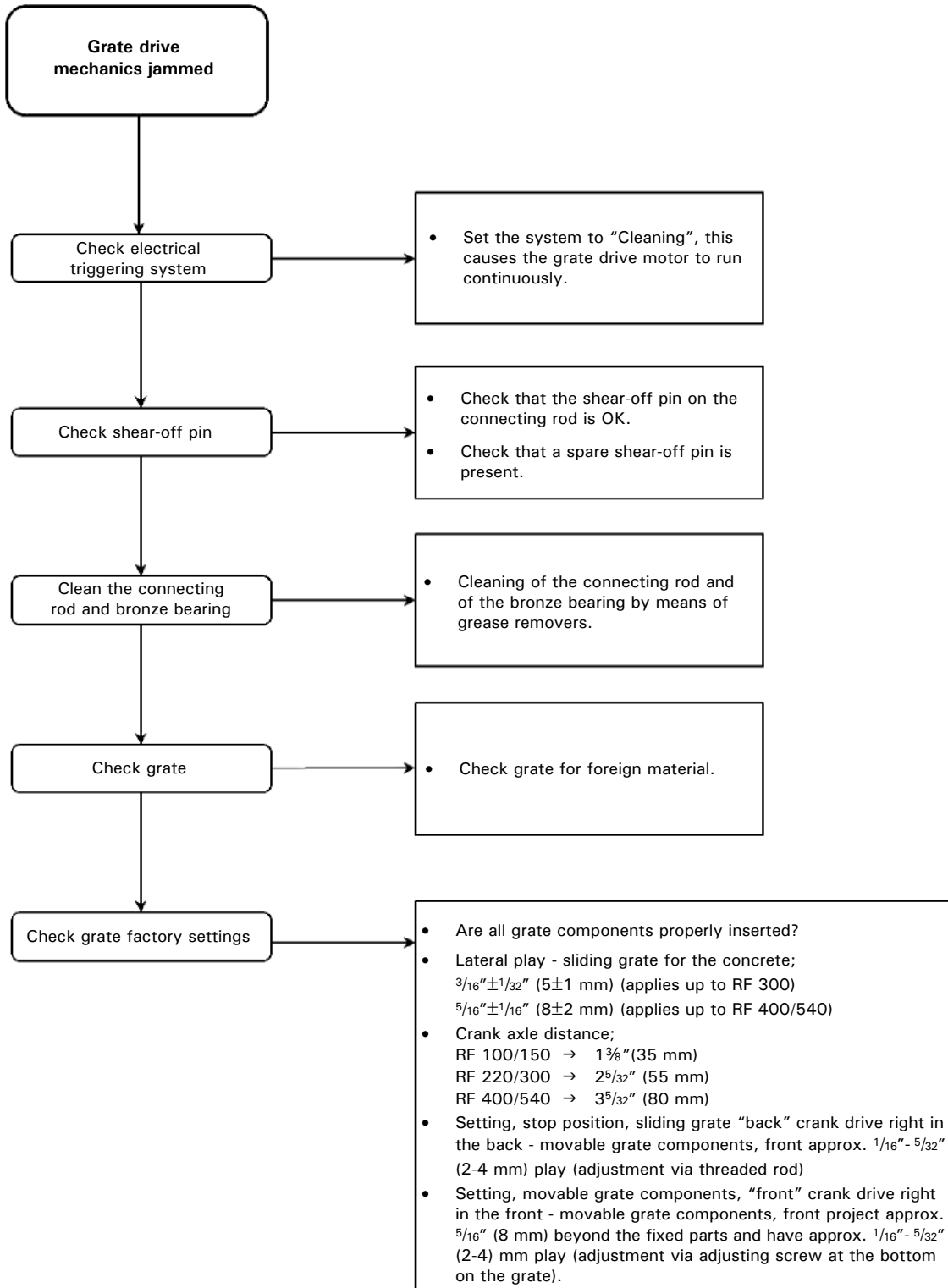

## Checking for Increased Wear of Fireclay

Increased fireclay wear can be observed in the substructure or in the curved bricking.

Fireclay must only be replaced when:

- the curved bricking is broken downwards (not already in the event of formation of cracks or spalling)
- fireproof panel located on the back of the fireclay can be seen in the substructure

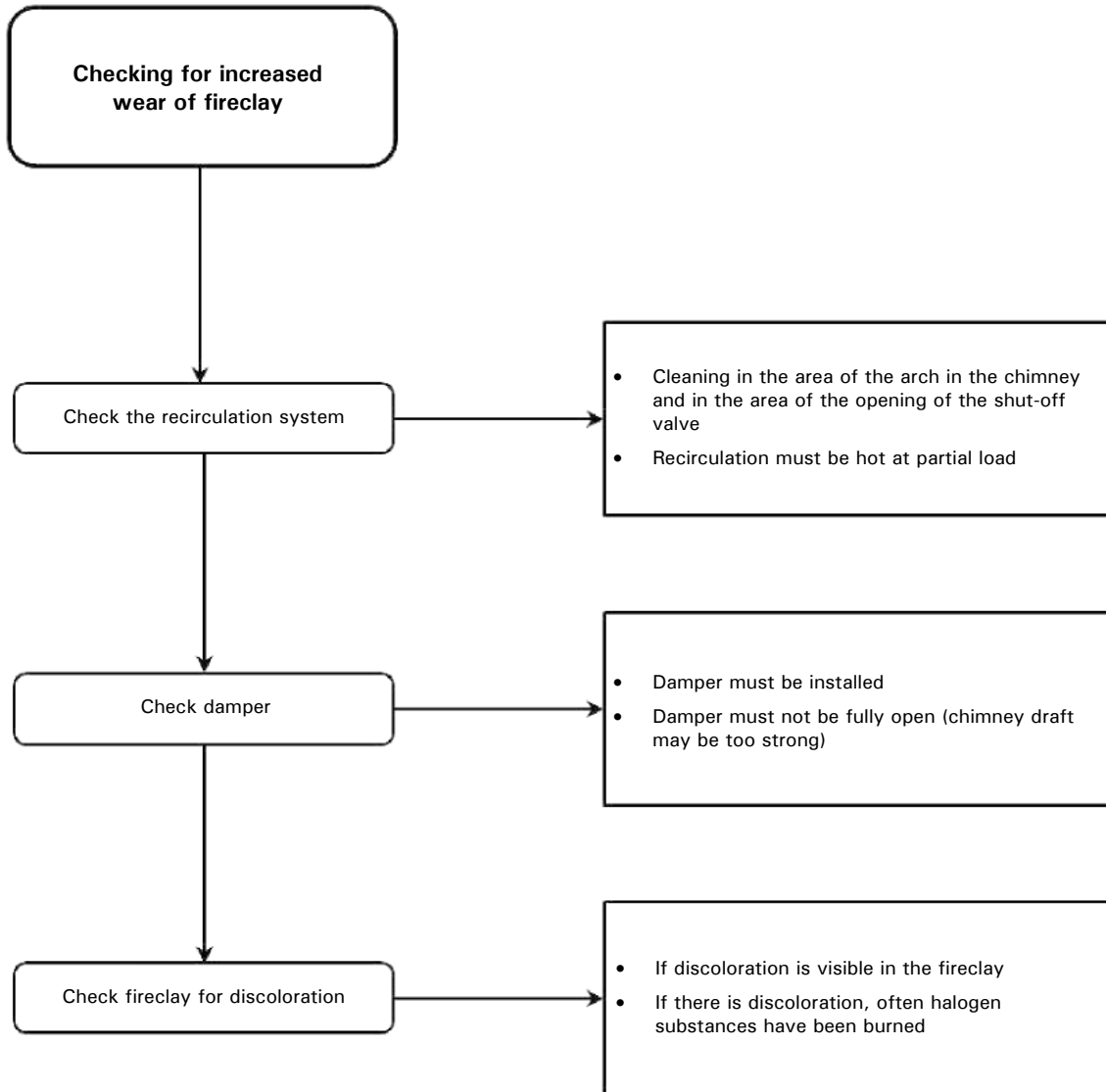

## Checking the Inside of the Boiler Door

Checking the inside of the boiler door can indicate whether the fibre glass seal is properly applied. If the seal is not properly applied, higher levels of CO gas can form. Checking the inside of the door can also indicate whether the guide tube is indicating increased wear. This is a danger especially at higher temperatures.

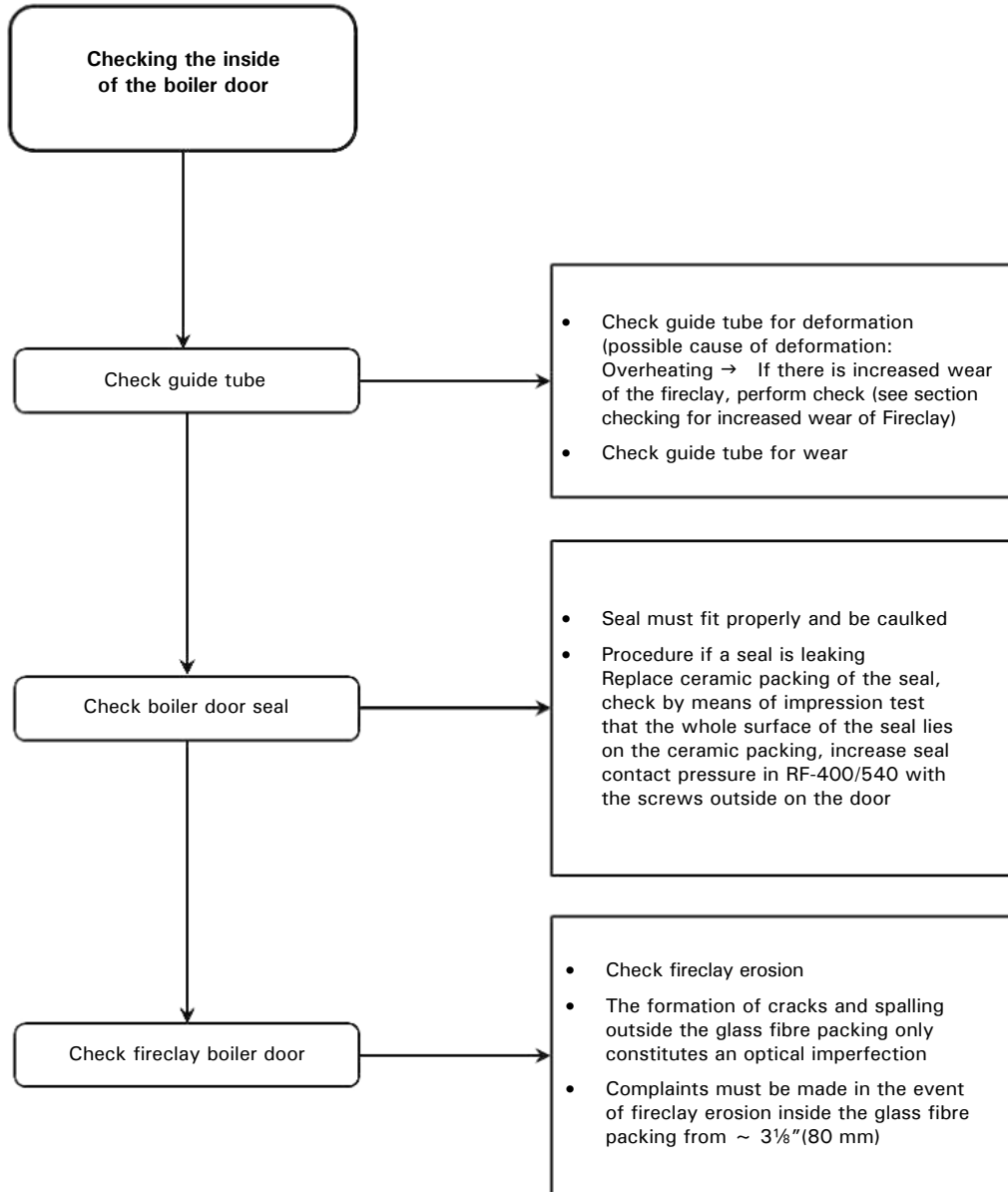

## Checking Oxygen Control System

A check of the oxygen control is carried out in case of incomplete combustion, dark smoke escaping the chimney or performance problems.

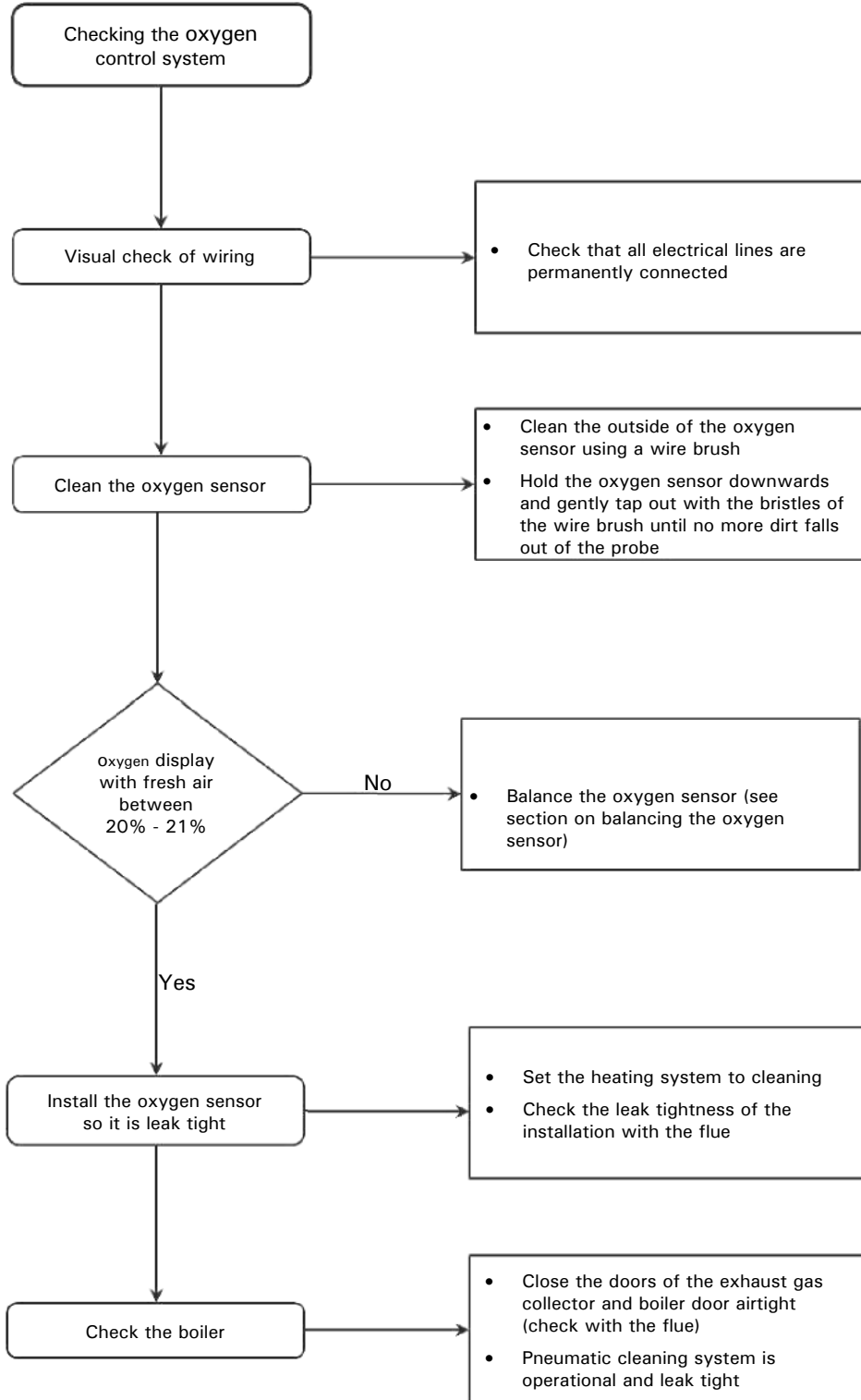



## Balancing the Oxygen Sensor

The oxygen sensor is subject to ageing which can be compensated by a oxygen sensor compensation.  
 The oxygen sensor compensation is necessary if the residual oxygen to fresh air is < 20%.

**! CAUTION**

The oxygen sensor is constantly heated and is very hot.

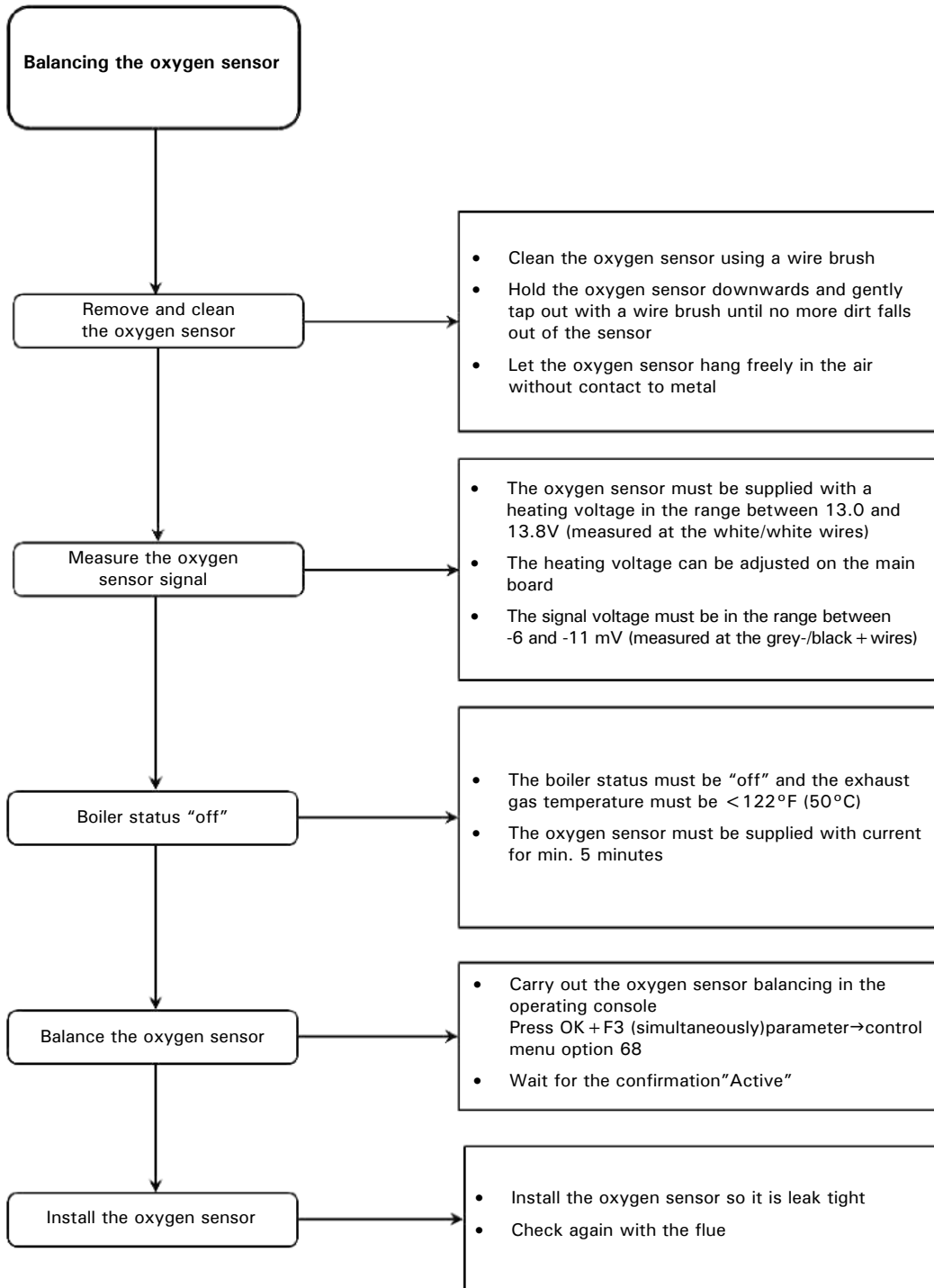

## Heating System Faults

Fault No.	Text displayed	Indicator	Possible cause	Check / remedy
01	Excess temperature (red light at F1, F2, F3)	Fixed high limit N21	<ul style="list-style-type: none"> <li>- Incorrect setting in the control module</li> <li>- Defective component (pump or valve)</li> <li>- Sudden drop in output to zero. The feed auger then has to be emptied. The heat produced by this can result in excess temperature. Activate the function "Dissipate excess heat"</li> </ul>	<ul style="list-style-type: none"> <li>- Why could the heat not be dissipated?</li> <li>- Check the boiler pump and mixing valve</li> <li>- Activate the function "Dissipate excess heat"</li> <li>- Unscrew the protective cap on the fixed high limit and press the reset button (not possible until the boiler temperature is less than 158°F (70°C) and press OK</li> </ul>
03-17	Interruption or short-circuit, sensor	- Sensor . . .	<ul style="list-style-type: none"> <li>- Damaged sensor connection line</li> <li>- Indicator defective</li> </ul>	Call a qualified electrician
09	Oxygen sensor (red light at F3)	- Oxygen sensor in the flue gas pipe	<ul style="list-style-type: none"> <li>- Indicator very soiled</li> <li>- Indicator defective</li> <li>- Error in the electronics</li> </ul>	<ul style="list-style-type: none"> <li>- Readjust oxygen sensor</li> <li>- Acknowledge with OK</li> </ul>
18	Permanent code (red light at F3)	- Operating hours lapsed before the permanent code has been entered	- Permanent code has not been entered	- Call Viessmann
19	Repeat heating up (red light at F3)	<ul style="list-style-type: none"> <li>- Exhaust gas temperature sensor</li> <li>- Oxygen sensor</li> </ul>	<ul style="list-style-type: none"> <li>- Fuel too moist</li> <li>- Oxygen sensor imprecise</li> <li>- Igniter defective</li> <li>- The combustion chamber filling time is too short</li> </ul>	<ul style="list-style-type: none"> <li>- Use suitable, dry fuel</li> <li>- Readjust oxygen sensor.</li> <li>- Replace ignition device</li> <li>- Readjust combustion chamber</li> <li>- Acknowledge with OK</li> </ul>
20	Water level in extinguishing Water container (red light at F3)	- Level float switch in extinguishing water container	- Not enough water in the extinguishing water container	<ul style="list-style-type: none"> <li>- Fill extinguishing water container</li> <li>- Acknowledge with OK</li> </ul>
25	Light barrier, ember monitoring system (red light at F3)	- Light barrier for ember monitoring system	<ul style="list-style-type: none"> <li>- Sight glass soiled; deposits of ash in the openings</li> <li>- Defective indicator</li> </ul>	<ul style="list-style-type: none"> <li>- Remove and clean sight glasses on both sides</li> <li>- Remove dust and ash deposit from the openings</li> <li>- Refer to the section, "Cleaning"</li> <li>- Acknowledge with OK</li> </ul>
26	Light barrier, feed auger (red light at F3)	- Light barrier in the metering container for the feed auger	<ul style="list-style-type: none"> <li>- Light barrier soiled</li> <li>- Clogging in the metering container</li> </ul>	<ul style="list-style-type: none"> <li>- Clean light barrier</li> <li>- Remove clogging</li> <li>- Acknowledge with OK</li> </ul>
96	Feed auger pipe too hot	- Temperature sensor on the feed auger	<ul style="list-style-type: none"> <li>- Power failure</li> <li>- Consequent malfunction caused by excess temperature</li> <li>- Light barriers for ember monitoring system soiled</li> </ul>	<ul style="list-style-type: none"> <li>- Call a qualified electrician</li> <li>- Check light barriers for embers</li> <li>- Acknowledge with OK</li> </ul>
81-93	BUS error, no connection to the (red light at F3)	- Data transmission line for the bus connection	- Bus connection interrupted	<ul style="list-style-type: none"> <li>- Check plug connections</li> <li>- Replace data transmission line</li> <li>- Call Viessmann</li> </ul>
53-54	Extraction system ... silo door open (red light at F4)	- Limit switch for silo door	- Silo door open	<ul style="list-style-type: none"> <li>- Check and close silo door</li> <li>- Acknowledge with OK</li> </ul>

## Loader System Faults

Fault No.	Text displayed	Indicator	Possible cause	Check / remedy
01	Material shortage (red light at F4)	- Light barrier in the metering container - Light barriers for the ember monitoring system	- Silo is empty - Conveyance system is clogged/jammed	- Fill silo - Turn off main switch and remove material clogging - Acknowledge with OK
11-24	Soft starter ... (red light at F4)	- Soft starter - Red light at the soft starter	- Phase sequence mixed up - Motor overloaded - Other causes, depending on the malfunction displayed	- Correct the phase sequence (clockwise rotating magnetic field) - Remove clogging - Refer to documentation for soft starter - Acknowledge with OK
30	Feed auger (red light at F4)	- Reversed control of in-feed auger	- Material clogging in the in-feed auger	- Remove material clogging
31-45	Conveyor device ... (red light at F4)	- Maintenance cover limit switch	- One of the maintenance covers is open or not closed properly	- Check and close all the maintenance covers - Acknowledge with OK
51-52	Extraction system ... (red light at F4)	- Maintenance cover limit switch	- One of the maintenance covers is open or not closed properly	- Check and close all the maintenance covers - Acknowledge with OK
53-54	Extraction system ... Hydraulic drive, temperature/level (red light at F4)	- Level float switch in the oil container for the walking floor extraction system - Thermostat in the oil container	- Oil level too low, (possible loss of oil) - Oil has been overheated by too high pressure	- Refill oil. Check oil line for leakage - Check and adjust operating pressure - Acknowledge with OK
53-54	Extraction system ... silo door open (red light at F4)	- Limit switch for silo door	- Silo door open	- Check and close silo door - Acknowledge with OK
01-27	Interruption or short-circuit, sensor ... (red light at F4)	- Sensor . . .	- Damaged sensor connection line - Indicator defective	- Call a qualified electrician

**Quick Reference**

°C	°F
-40	-40
-35	-31
-25	-13
-20	-4
-18	0
-16	+3
-14	+7
-12	+10
-10	+14
-9	+16
-8	+18
-7	+19
-6	+21
-5	+23
-4	+25
-3	+27
-2	+28
-1	+30
0	+32
+1	+34
+2	+36
+3	+37
+4	+39
+5	+41
+6	+43
+7	+45
+8	+46
+9	+48
+10	+50
+12	+54
+14	+57
+16	+61
+18	+64
+20	+68
+25	+77
+30	+86
+35	+95
+40	+104
+50	+122
+60	+140
+70	+158
+80	+176
+90	+194
+100	+212
+110	+230

Viessmann Manufacturing Company Inc.  
 750 McMurray Road  
 Waterloo, Ontario • N2V 2G5 • Canada  
**TechInfo Line 1-888-484-8643**  
 1-800-387-7373 • Fax (519) 885-0887  
 www.viessmann.ca • info@viessmann.ca

Viessmann Manufacturing Company (U.S.) Inc.  
 45 Access Road  
 Warwick, Rhode Island • 02886 • USA  
**TechInfo Line 1-888-484-8643**  
 1-800-288-0667 • Fax (401) 732-0590  
 www.viessmann-us.com • info@viessmann-us.com

Printed on environmentally friendly  
 (recycled and recyclable) paper.



Technical information subject to change without notice.