

Connection Fittings Installation Guide

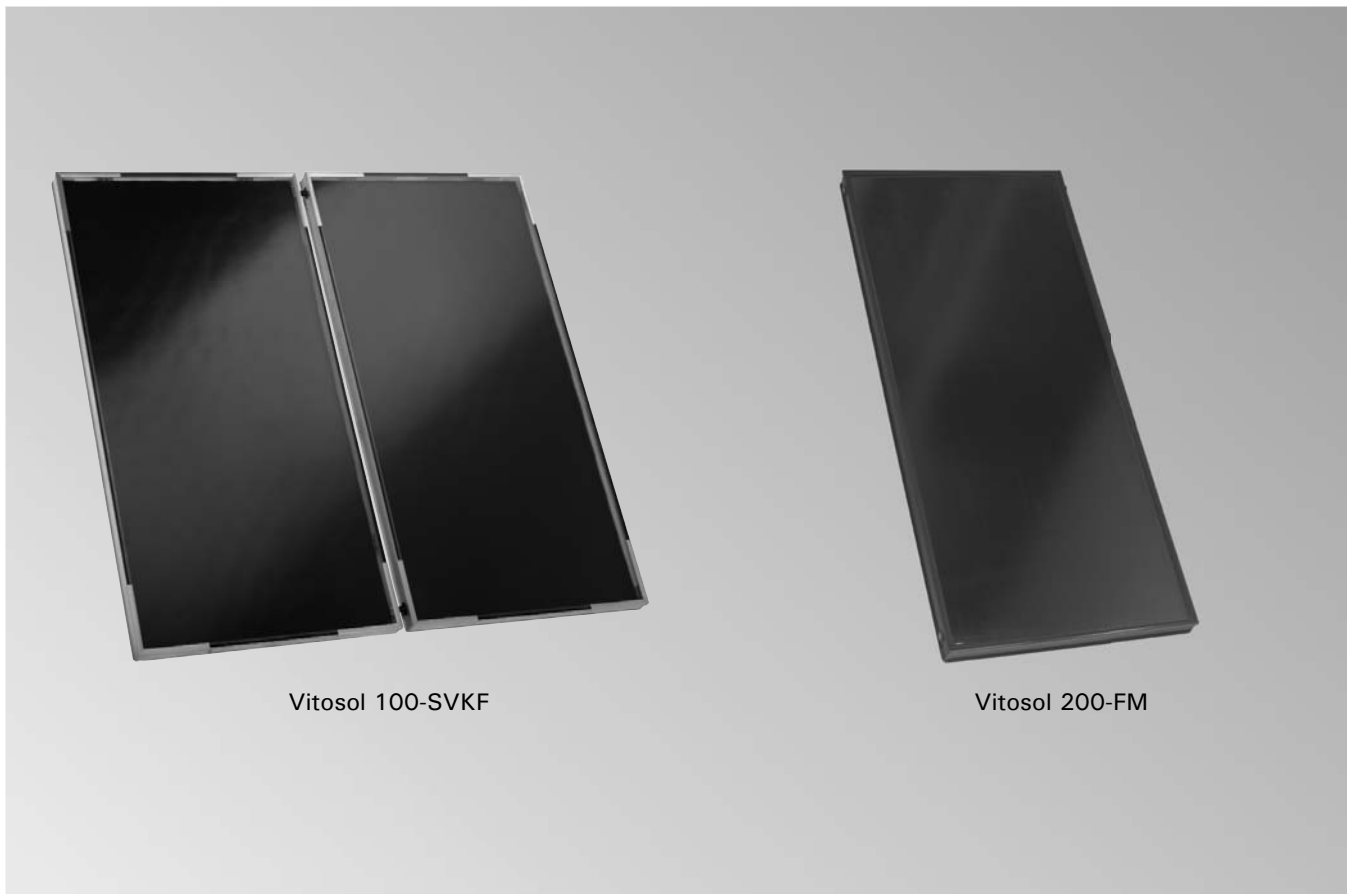

VITOSOL®





Vitosol 100-SVKF

Vitosol 200-FM



**Vitosol DHW Solar Pack
Vitosol 200-FM Flat Plate Collectors**

	Page
Parts and Components	
Fitting Sets and Kits	3
Collector Loop Fittings	3
Spare Parts / Individual Fittings	5
Layout Drawings	
Connection Fitting Parts Index	7
Connection Fittings for DHW Solar Pack.....	8
Connection Fittings for 200-FM with Solar-Divicon DN20B/DN25B	11
Piping Connections for Expansion Tanks.....	16
Contacts	
Contacts	17







Fitting Sets and Kits

Item	Description	Part Number
<p>General Connection Set</p> 	<p>One set required for each Vitosol 200-FM collector array. Array size can be 1 to 12 collectors. Contains all the required fittings for pipe connection to collector.</p> <p>Contents:</p> <ul style="list-style-type: none"> ■ 2 x brass connecting pipe (one long, one short) ■ 2 x brass plugs ■ 4 x stainless steel profile clamp ■ 2 x 22 mm 90° compression elbow ■ 1 x package of O-ring silicone assembly grease ■ 2 x copper tube support inserts 	<p>200-FM 7248240</p>
<p>Installation Fittings Set</p> 	<p>One set required for each system. Contains the metric conversion fittings required to connect to the collector array and the conversion adaptor for the expansion tank fitting.</p> <p>Contents:</p> <ul style="list-style-type: none"> ■ 4 x copper pipe adaptors – 22 mm dia to 3/4" dia x 4" long ■ 1 x copper pipe stub – 22 mm dia x 2.4" long ■ 1 x 3/4" BSPT Female x 3/4" NPT male adaptor ■ 1 x gasket ■ 1 x package of technical literature 	<p>200-FM ZK02868 (CA) ZK02870 (USA)</p>





Collector Loop Fittings

Item	Description	Part Number
<p>Interconnection Pipe Set</p> 	<p>Used to connect Vitosol 200-FM collectors together. Brass fittings with double O-ring seal, connected by flexible stainless steel pipe.</p> <p>Contents:</p> <ul style="list-style-type: none"> ■ 2 x interconnection pipes ■ 1 x package of O-ring silicone assembly grease 	<p>200-FM 7248239</p>
<p>Sensor Well Set</p> 	<p>Collector sensor well set for Vitosol 200-FM. One required per system. Installed in top collector outlet piping.</p> <p>Contents:</p> <ul style="list-style-type: none"> ■ 1 x 22 mm compression tee ■ 1 x immersion sensor well ■ 1 x sensor wire strain relief ■ 1 x insulation cover ■ 1 x copper tube support insert 	<p>200-FM 7174993</p>



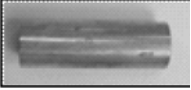

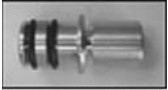
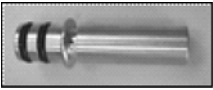
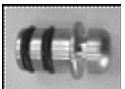
Collector Loop Fittings *(continued)*

Item	Description	Part Number
<p>Automatic Fast Air Vent</p> 	<p>Air vent for high point of each collector array. Built in shut-off valve for 100% isolation after system is totally vented 22 mm brass compression couplings.</p> <p>Note: If ordered individually, requires 2 x PN 9543380 - copper adaptors – 22 mm x 3/4" x 4".</p>	<p>200-FM 7316789</p>
<p>Manual Air Vent</p> 	<p>Air vent for high point of each collector array. Can be used as an alternate to the Fast Air Vent. Manual key vent, 22 mm brass compression couplings.</p> <p>Note: If ordered individually, requires 2 x PN 9543380 - copper adaptors – 22 mm x 3/4" x 4".</p>	<p>200-FM 7316263</p>
<p>Automatic Air Vent With Micro-Bubble Mesh</p> 	<p>Air separator for location in mechanical room. Wire mesh micro-bubble separator, with built in shut-off valve 22 mm brass compression couplings.</p> <p>Note: If ordered individually, requires 2 x PN 9543380 - copper adaptors – 22 mm x 3/4" x 4".</p>	<p>7316049</p>
<p>Brass Elbow With Sensor Well</p>  	<p>Solar tank sensor well for Vitocell tanks. Installs on solar glycol return line to collectors.</p> <p>Note: Must be ordered separately for all other tanks.</p>	<p>1" probe, for Vitocell 300-W tanks, 42 USG: – for tanks with NPT threads 7606041</p> <p>1" probe, for Vitocell 300-B, 300-V tanks, 53 to 79 USG: – for tanks with NPT threads 7606041</p> <p>1 1/4" probe, for Vitocell 300-B, 300-V tanks, 119 USG: – for tanks with NPT threads 7606042</p>
<p>Expansion Tank Flex Pipe</p> 	<p>Flexible 3/4"G x 19" (500 mm) long Stainless steel flexible connection pipe. Used to connect expansion tank to Solar-Divicon DN20B / DN25B. Compression fitting with gasket.</p> <p>Note: Only for use with the following tank models: 18L, 25L, 40L</p>	<p>7497468</p>

Spare Parts / Individual Fittings

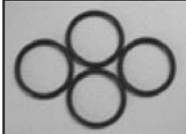
Item	Description	Part Number
<p>Copper Adaptor</p> 	<p>Included with the Installation Fittings Set (see page 3), but can be ordered individually.</p> <p>Used to connect standard NPT copper to all Vitosol fitting with compression couplings (eg. Supply/Return piping to 90° compression elbow).</p> <p>Copper adaptor pipe stub – 22 mm dia x ¾" Copper x 4" long.</p>	<p>200-FM 9543380</p>
<p>Copper Connector</p> 	<p>Included with the Installation Fittings Set (see page 3), but can be ordered individually.</p> <p>Used to connect two items together that both have 22 mm compression couplings (eg. Air vent and sensor well).</p> <p>Copper pipe stub – 22 mm dia x 2.4" long.</p>	<p>200-FM 5276590</p>
<p>Vitosol Profile Clamp</p> 	<p>Included with the General Connection Set (see page 3), but can be ordered individually.</p> <p>Used for Vitosol 200-FM to attach brass connection pipes and plugs to the collector header pipe.</p>	<p>200-FM, 7317074</p>
<p>Brass Collector Connection Pipe – Short</p> 	<p>Included with the General Connection Set (see page 3), but can be ordered individually.</p> <p>Used for Vitosol 200-FM to connect piping to the collector header pipe.</p>	<p>200-FM 7827514</p>
<p>Brass Collector Connection Pipe – Long</p> 	<p>Included with the General Connection Set (see page 3), but can be ordered individually.</p> <p>Used for Vitosol 200-FM. To connect piping to the collector header pipe.</p>	<p>200-FM 7827515</p>
<p>Brass Collector Plug</p> 	<p>Included with the General Connection Set (see page 3), but can be ordered individually.</p> <p>Used for Vitosol 200-FM to plug the collector header pipe.</p>	<p>200-FM 7827516</p>
<p>Compression Connector – Union</p> 	<p>Brass union fitting with 22 mm compression fittings (sold in a set of 2).</p> <p>Used for a straight connection between two 22 mm pipes: - To bring S/R piping straight out of collector instead of using 90° compression elbow.</p> <p>To extend pipe between two collectors that have to span an obstruction.</p>	<p>All collectors 7819612</p>

Spare Parts / Individual Fittings *(continued)*

Item	Description	Part Number
<p>Compression Connector, 90° Elbow</p> 	<p>Brass elbow fitting with 22 mm compression fittings. Included with the General Connection Set, but can be ordered individually.</p>	<p>All collectors 7819611</p>
<p>Collector Fitting O-rings</p> 	<p>Package of 4. Spare parts, used for all collector fittings.</p>	<p>200-FM 7819604</p>
<p>Silicone Assembly Grease</p> 	<p>6 gram package. Included with the General Connection Set (see page 3) and with the Interconnection Pipe Set (see page 4). This can be ordered individually. Used for lubricating O-rings on all collector fittings.</p>	<p>All collectors 7819602</p>
<p>Solar Divicon Expansion Tank Adaptor Fitting</p> 	<p>Coupling, 3/4" BSPT x 3/4" NPT Brass. Included with the Solar Divicon fittings, but can be ordered individually. Used to connect NPT piping to the expansion tank connection on all Solar Divicon.</p>	<p>All Solar Divicon 7134829</p>
<p>Expansion Tank Service Valve Adaptor Fitting</p> 	<p>Adaptor, 3/4" G female - 3/4" NPT male. Included with the Installation Fittings Set (see page 4), but can be ordered individually. Used to connect NPT piping to the service valve on the expansion tank.</p>	<p>18 to 50 L Expansion Tanks 9635592</p>
<p>Flat Gasket</p> 	<p>Flat Gasket, 17 x 24 x 1.5mm Used with solar divicon expansion tank adaptor, expansion tank service valve adaptor, solar expansion tank service valve & flexible tank adaptor. This can be ordered individually.</p>	<p>9535412</p>

Connection Fittings Parts Index

①		Ø22mm Compression 90 deg Elbow
②		Connection Pipe - Short - 200-FM
③		Connection Pipe - Long - 200-FM
④		Connection Plug - 200-FM
⑤		Vitosol Profile Clamp - 200-FM & 1/2" Insulated Flexible S.S. Piping
⑥		Interconnection Pipe Set - 200-FM
⑦		S1 Sensor Well Set - 200-FM
⑧		Fast Air Vent c/w Shut-off
⑨		Copper Pipe Stub Ø22 mm x 2 1/2" Long
⑩		Copper Adaptor Pipe Stub - Ø22mm x Ø3/4" x 4" Long
⑪		Ø1/2" Rigid Copper Pipe (Field Supplied)
⑫		Ø3/4" Rigid Copper Pipe (Field Supplied)
⑬		Ø1" Rigid Copper Pipe (Field Supplied)
⑭		1/2" Insulated Flexible S.S. Piping
⑮		○ - Vitosol O-rings (Solar Rated)
⑯		○ - Vitosol Plastic Spacer (White)
⑰		⊞ ○ ⊞ Ø22mm Compression Nut - 1/2" SS Piping
⑱		○ ⊞ Ø22mm Compression Sleeve - 1/2" SS Piping
⑲		⊞ ⊞ Ø22mm Compression Adaptor - 1/2" SS Piping
⑳		⊞ ⊞ 3/4" BSPT x 3/4" NPT Brass Coupling
㉑		○ - Flat Fiber Gasket
㉒		⊞ ⊞ 3/4" G Female x 3/4" NPT Male Adaptor
㉓		Flexible S.S. Expansion Tank Adaptor
㉔		3/4" Expansion Tank Service Valve
㉕		1" Expansion Tank Service Valve
㉖		S2 Brass Elbow c/w Sensor Well
㉗		⊞ ⊞ Ø1/2" x Ø3/4" Copper Reducing Coupling (Field Supplied)
㉘		⊞ ⊞ Ø3/4" x Ø1" Copper Reducing Coupling (Field Supplied)
㉙		⊞ ⊞ 3/4" Female NPT x Ø3/4" Copper Sweat Adaptor (Field Supplied)
㉚		⊞ ⊞ 3/4" Male NPT x Ø3/4" Copper Sweat Adaptor (Field Supplied)
㉛		⊞ ⊞ 1" Male NPT x Ø1" Copper Sweat Adaptor (Field Supplied)
㉜		⊞ ⊞ Ø22mm Straight Compression
㉝		S1 200-F SVK Connection Set (Insulated Flexible S.S. Piping)
㉞		C Locking Clip

Connection Fittings for DHW Solar Pack

Note: Vitosol 100-FM SVKF with 1/2" copper piping, pumping station included with pack.

Note: See numbered parts index on page 7.

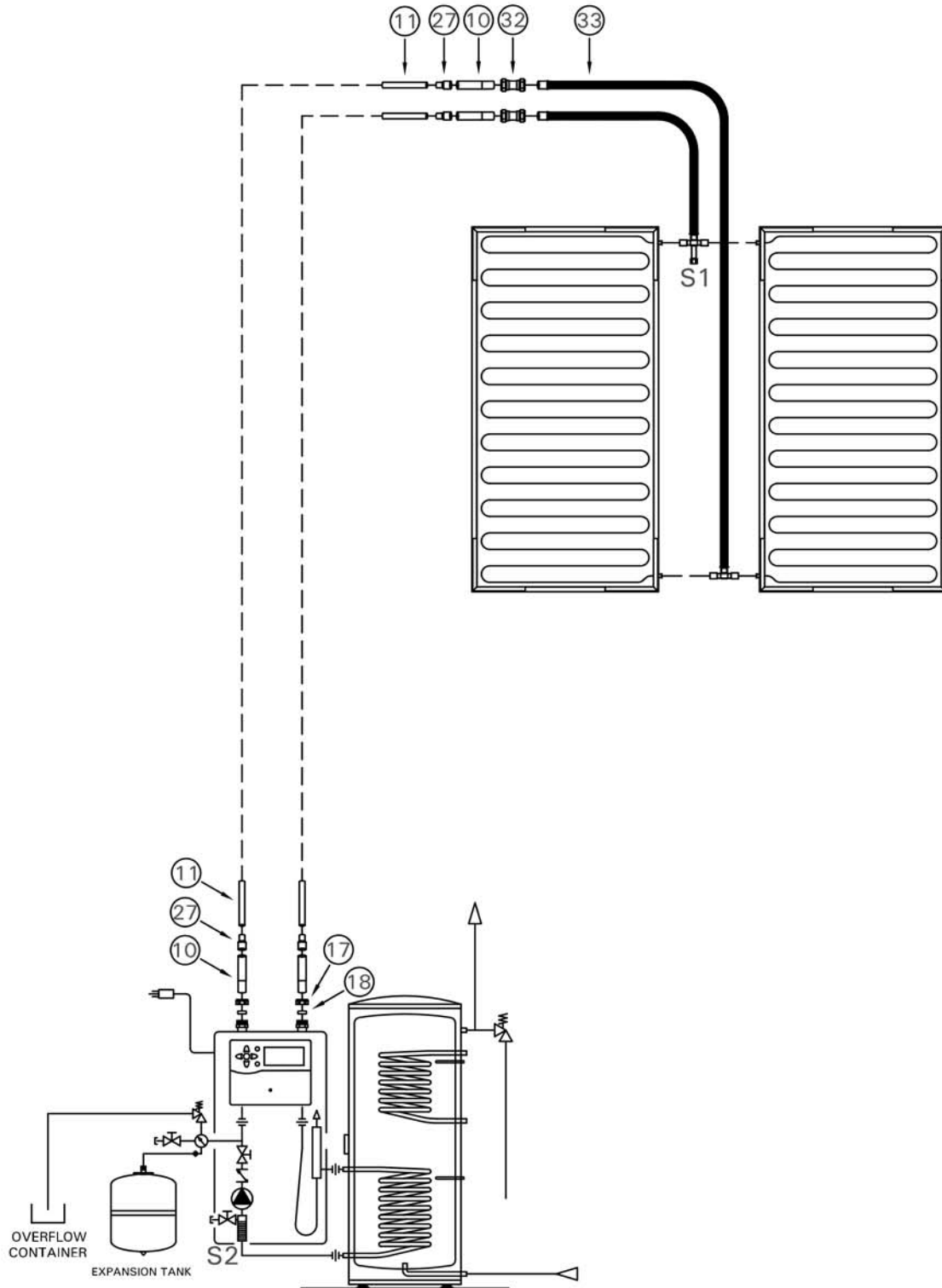

Connection Fittings for DHW Solar Pack *(continued)*

Note: Vitosol 100-FM SVKF with 1/2" stainless steel line set, pumping station included (with locking clip).

Note: See numbered parts index on page 7.

Note: Item 18 is not required.

IMPORTANT

The 1/2" stainless steel line set has a minimum bend radius of 2". If possible a bend radius larger than 2" is recommended.

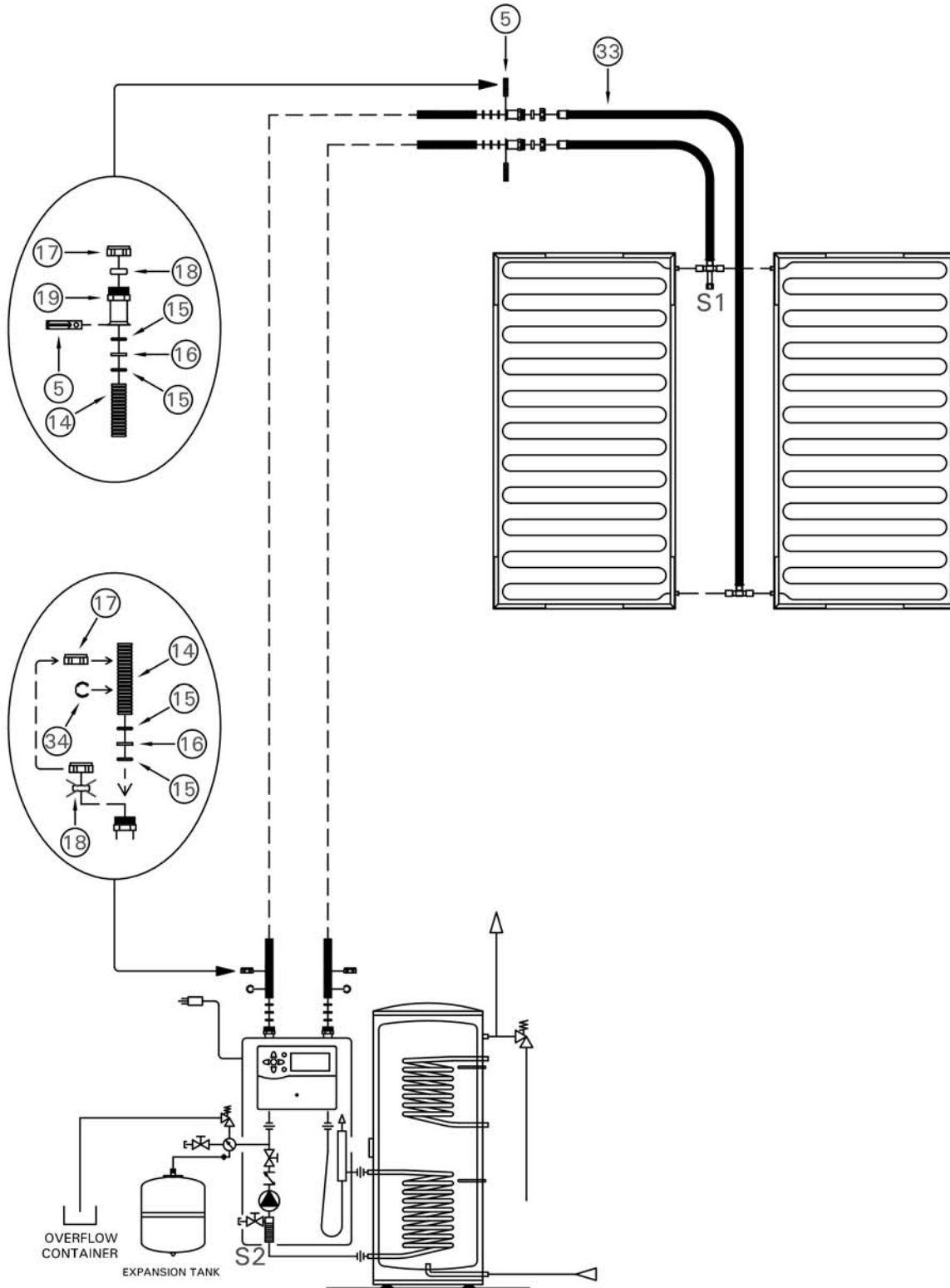

Connection Fittings for DHW Solar Pack *(continued)*

Note: Vitosol 100-FM SVKF with 1/2" stainless steel line set, pumping station included (with copper connector)

Note: See numbered parts index on page 7.

IMPORTANT

The 1/2" stainless steel line set has a minimum bend radius of 2". If possible a bend radius larger than 2" is recommended.

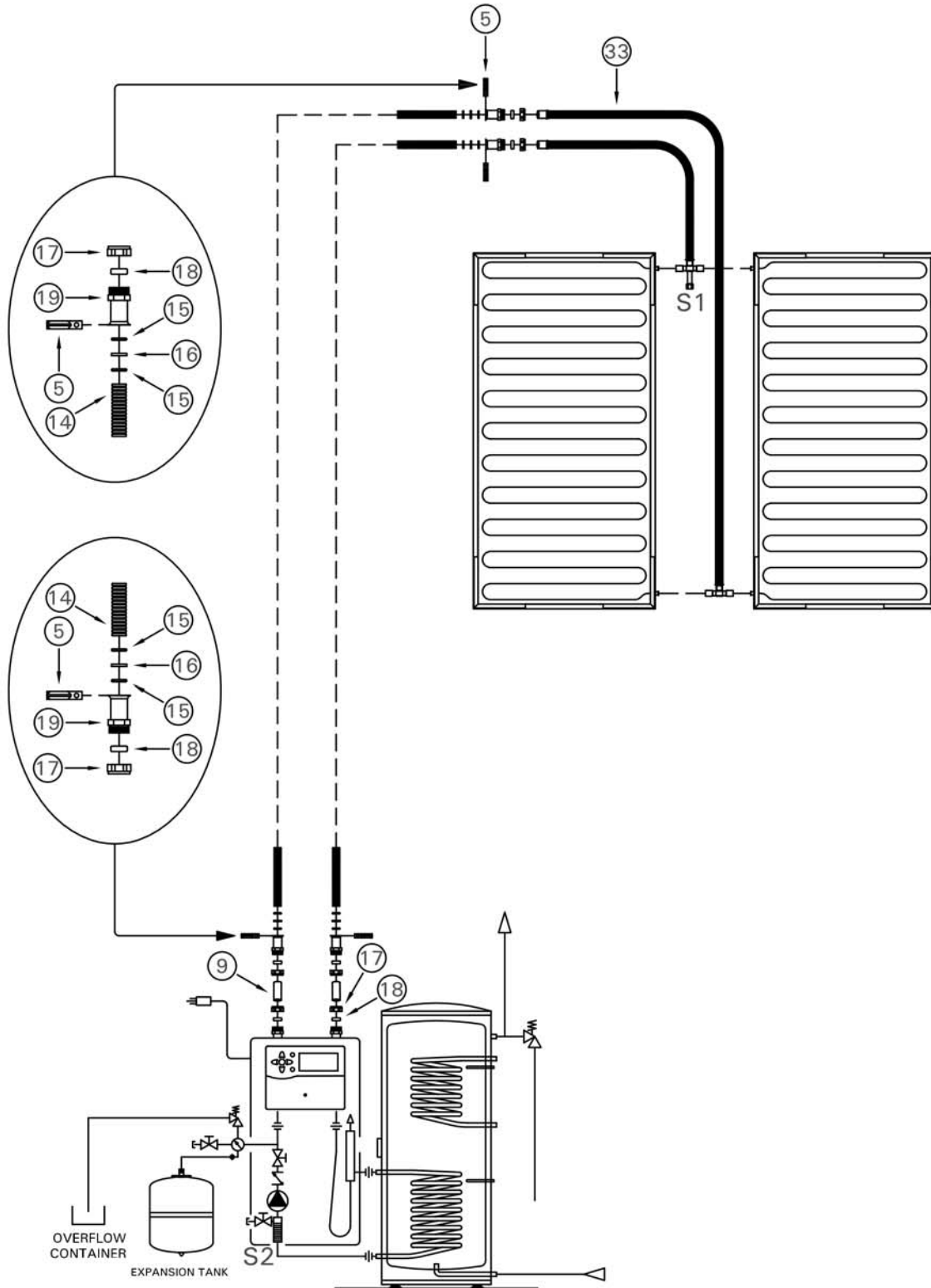

Connection Fittings for 200-FM with Solar-Divicon DN20B

Note: Vitosol 200-FM with 1/2" copper piping

Note: See numbered parts index on page 7.

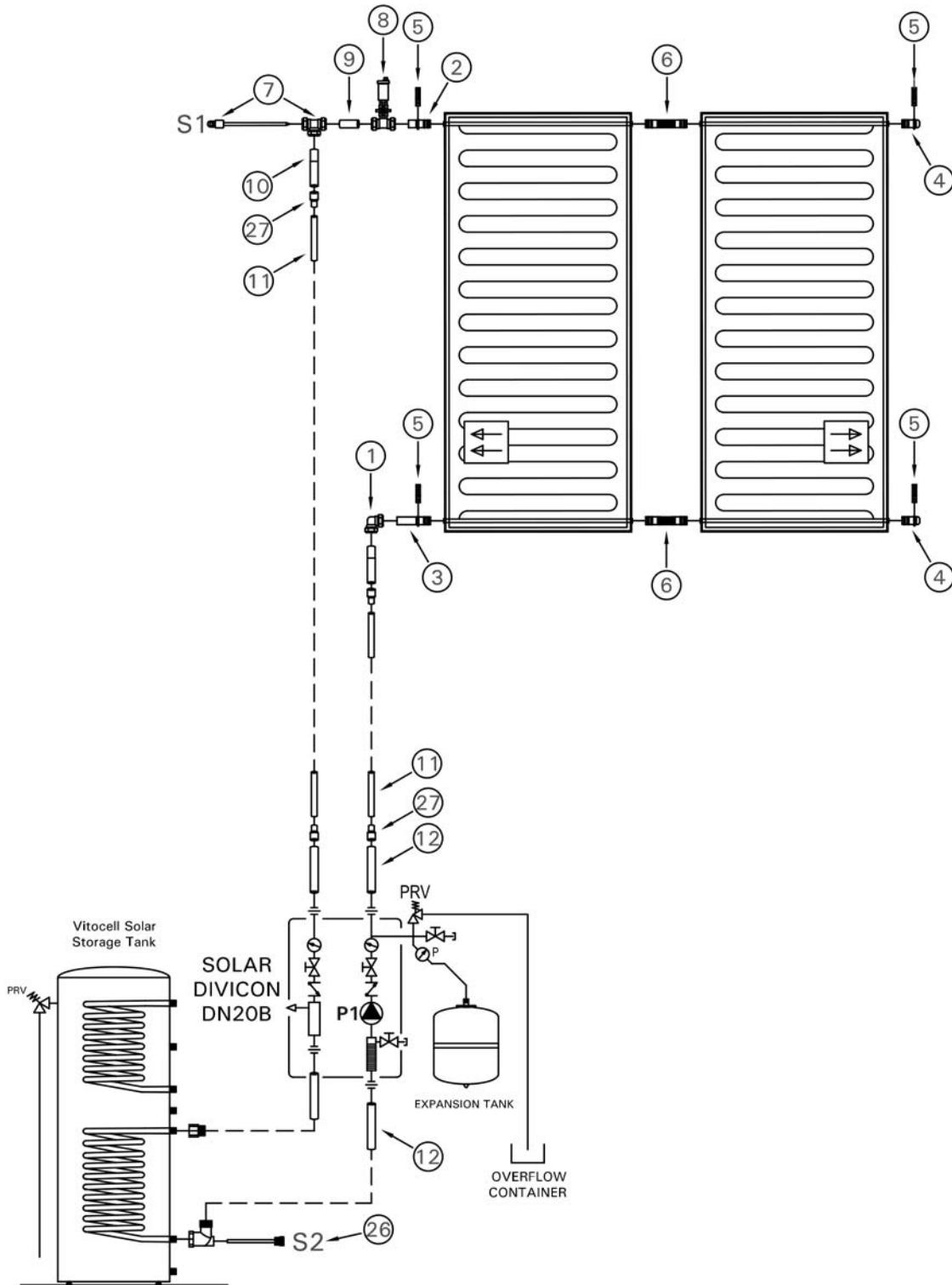

Connection Fittings for 200-FM with Solar-Divicon DN20B

Note: Vitosol 200-FM with 3/4" copper piping

Note: See numbered parts index on page 7.

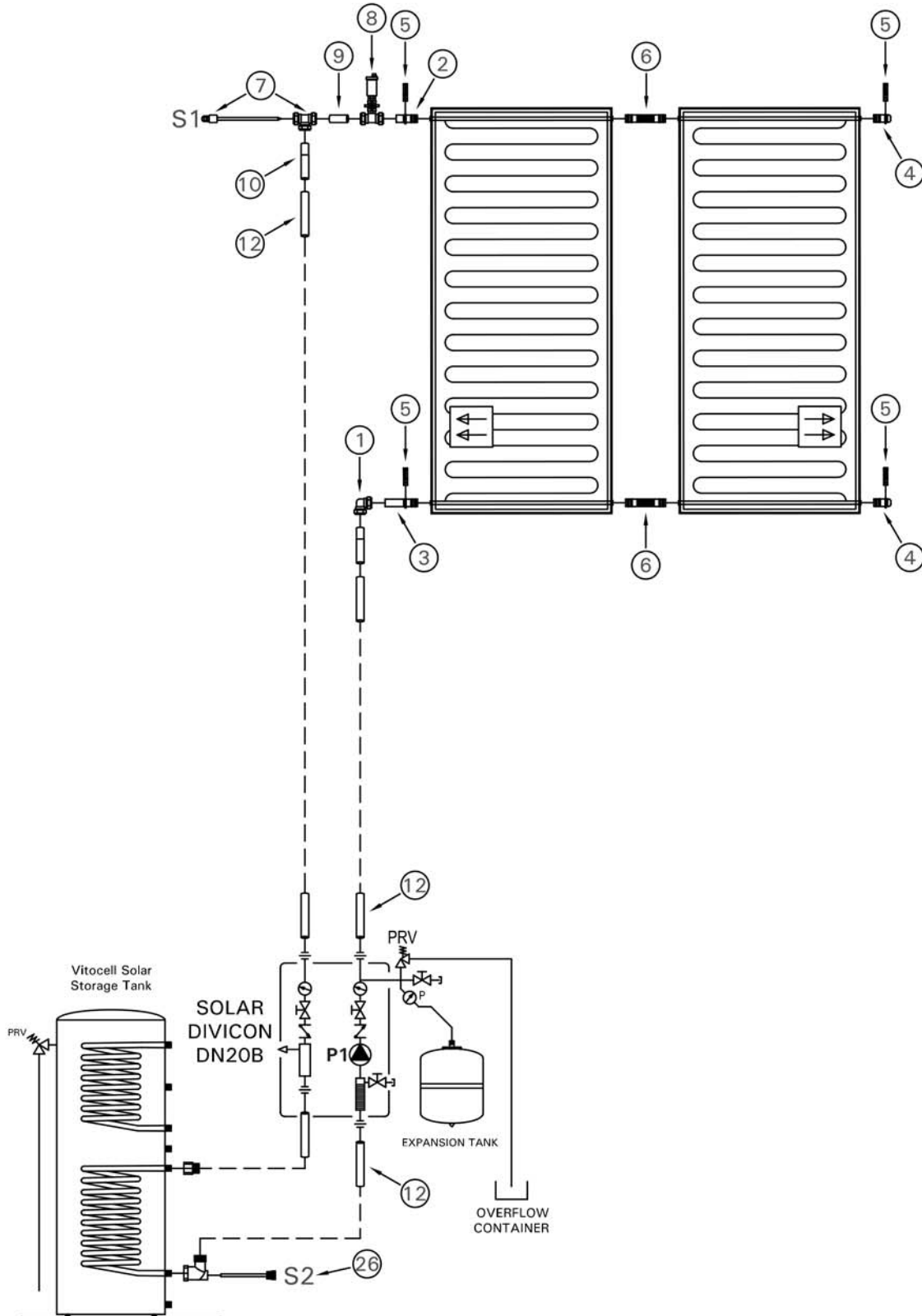

Connection Fittings for 200-FM with Solar-Divicon DN25B

Note: Vitosol 200-FM with 3/4" copper piping

Note: See numbered parts index on page 7.

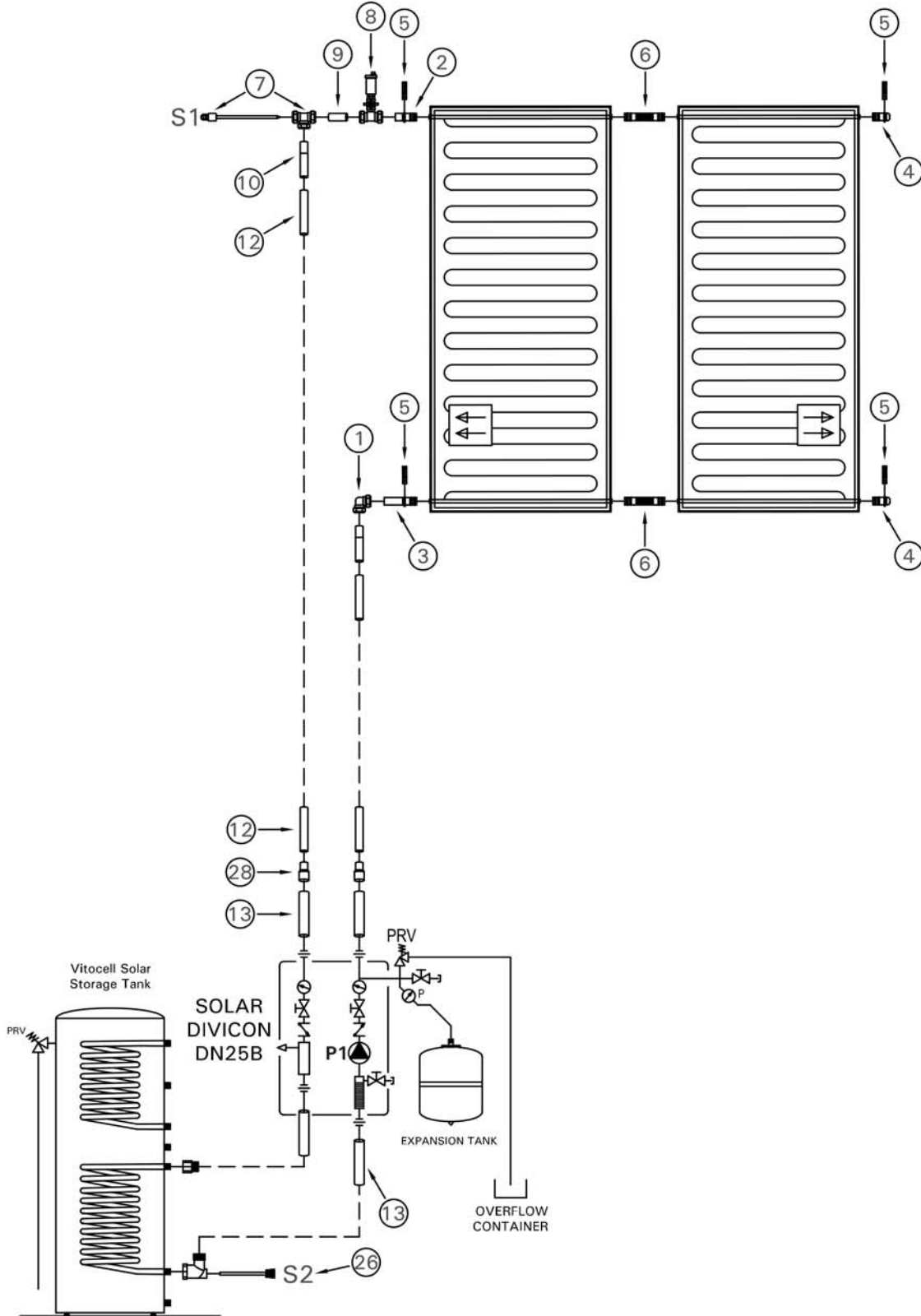

Connection Fittings for 200-FM with Solar-Divicon DN20B *(continued)*

Note: Vitosol 200-FM with 1/2" stainless steel line set.

Note: See numbered parts index on page 7.

IMPORTANT

The 1/2" stainless steel line set has a minimum bend radius of 2". If possible a bend radius larger than 2" is recommended.

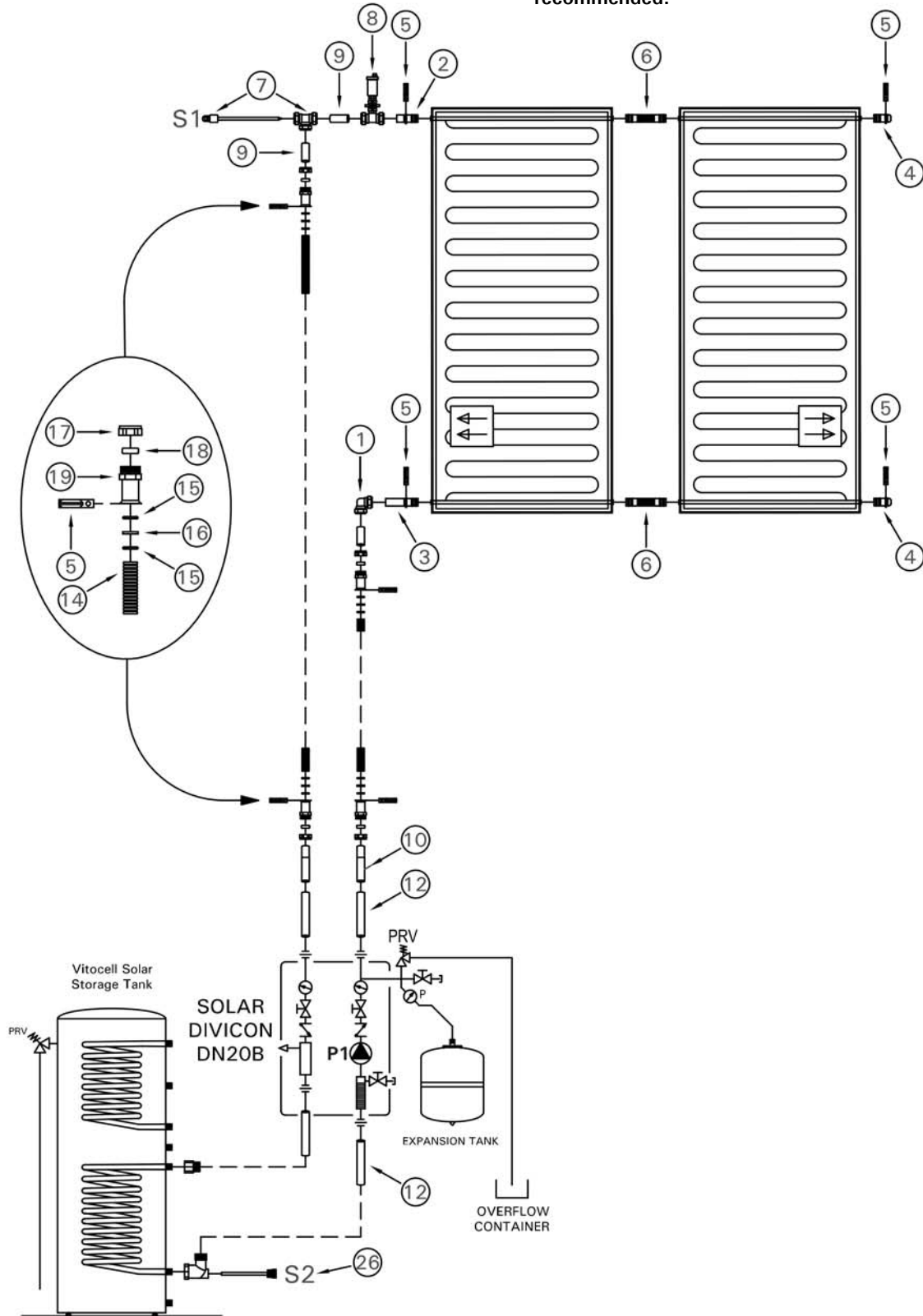

Connection Fittings for 200-FM with Solar-Divicon DN25B

Note: Vitosol 200-FM with 1/2" stainless steel line set.

Note: See numbered parts index on page 7.

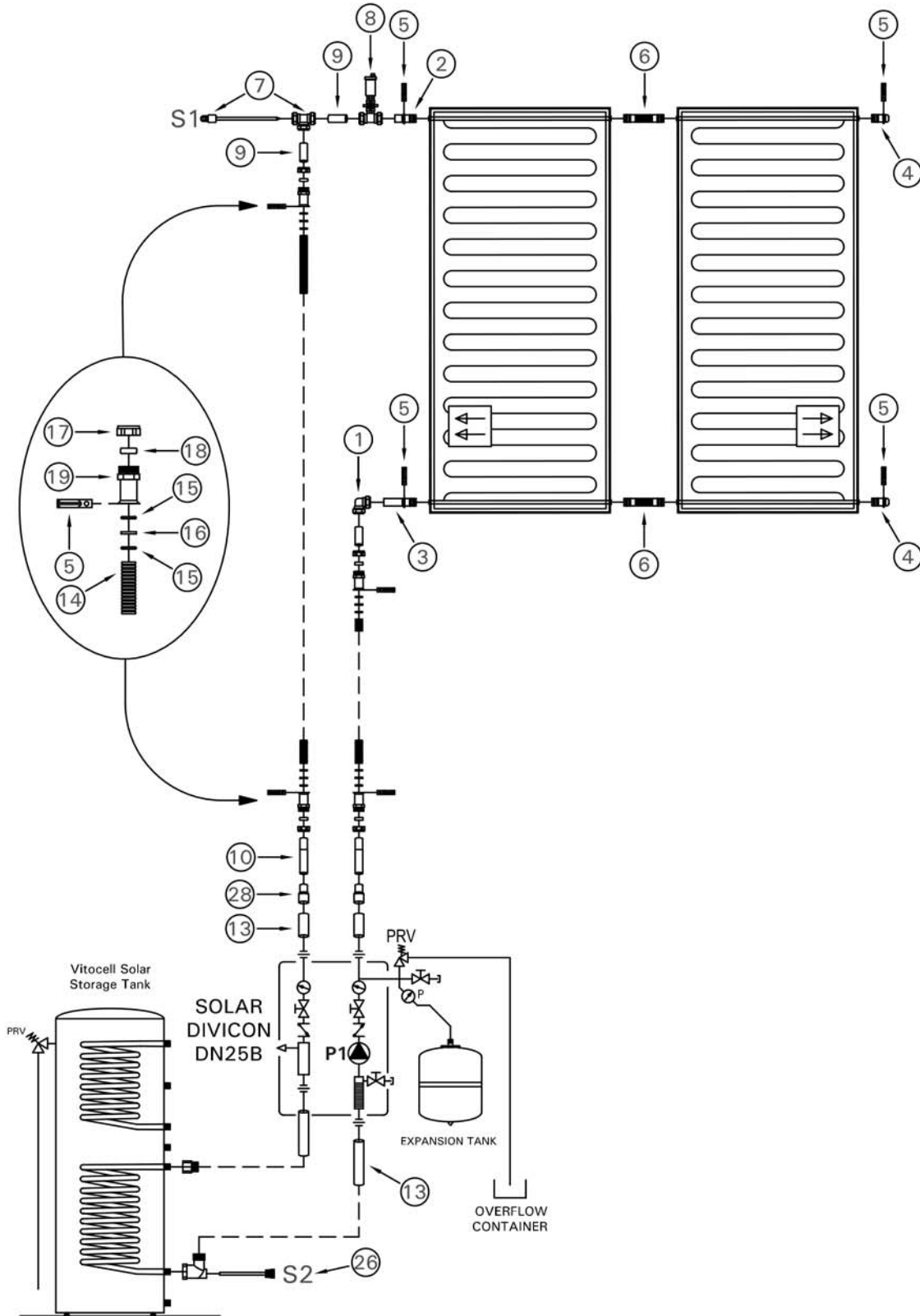

Expansion Tank Piping Connections

Note: See numbered parts index on page 7.

IMPORTANT

The 1/2" stainless steel line set (option #2) has a minimum bend radius of 2". If possible a bend radius larger than 2" is recommended.

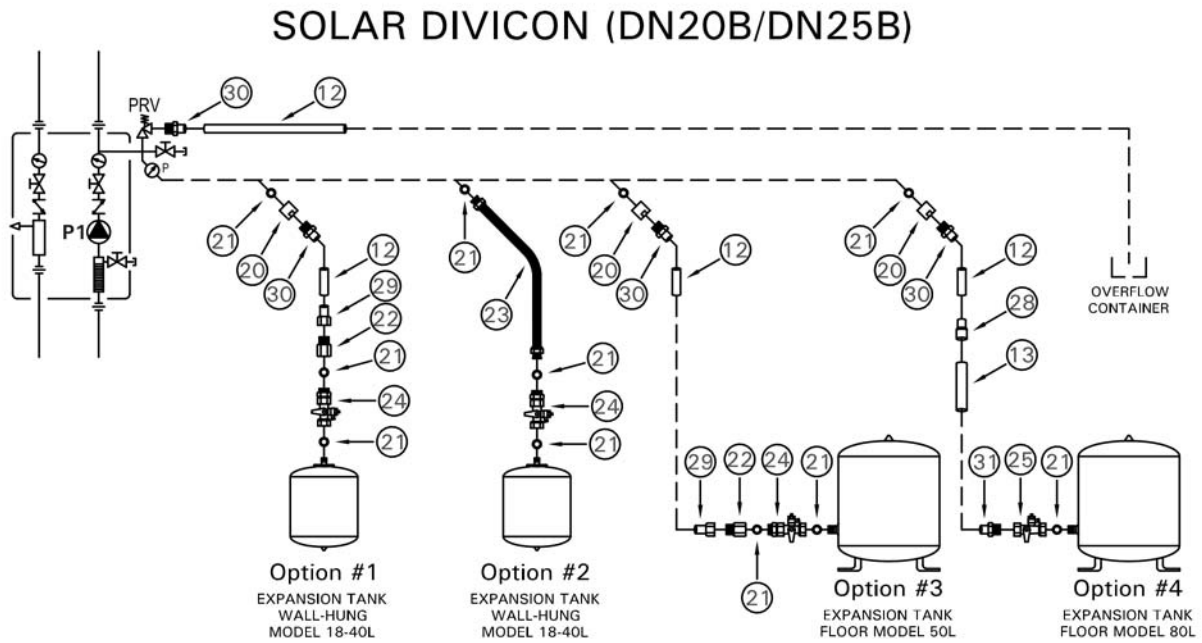

*Special Note:

-The 1/2" stainless steel lineset has a minimum bend radius of 2". If possible a larger bend radius would be recommended.

Contacts

If you have any questions about any of these connection fittings or connection drawings, please contact your Solar Technical Support Team:

Viessmann - Waterloo, Ontario, Canada
Steve Royce
1-519-885-6300
roys@viessmann.com

Viessmann - Langley, British Columbia, Canada
Scott Boutillier
1-604-533-9445
bous@viessmann.com

Viessmann - Warwick, Rhode Island, USA
Nick Toman
1-401-732-0667
tomn@viessmann.com







Printed on environmentally friendly
(recycled and recyclable) paper.

Technical information subject to change without notice.

Viessmann Manufacturing Company Inc.
750 McMurray Road
Waterloo, Ontario • N2V 2G5 • Canada
TechInfo Line 1-888-484-8643
1-800-387-7373 • Fax (519) 885-0887
www.viessmann.ca • info@viessmann.ca

Viessmann Manufacturing Company (U.S.) Inc.
45 Access Road
Warwick, Rhode Island • 02886 • USA
TechInfo Line 1-888-484-8643
1-800-288-0667 • Fax (401) 732-0590
www.viessmann-us.com • info@viessmann-us.com