

Operating and Service Instructions



Vitosol 200-T, SPE and SP2A
Vacuum Tube Solar Collector
Vitosol 100-F and 200-F
Flat Plate Solar Collector

For installation on sloped roofs, walls and for flat roofs with or without angled supports.
For heating domestic hot water, low-temperature heating systems and swimming pool water via a heat exchanger.

VITOSOL® 200-T **VITOSOL® 100-F and 200-F**



Vitosol 200-T
Model SPE



Vitosol 100-F
Model SV1B, SH1B
Vitosol 200-F
Model SV2C, SH2C

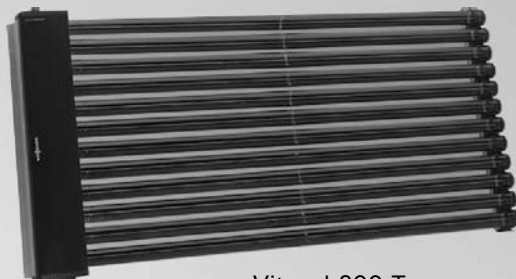

Vitosol 200-T
Model SP2A

IMPORTANT

Read and save these instructions for future reference.

Product may not be exactly as shown

Safety, Installation and Warranty Requirements

Please ensure that these instructions are read and understood before commencing installation. Failure to comply with the instructions listed below and details printed in this manual can cause **product/property damage, severe personal injury, and/or loss of life**. Ensure all requirements below are understood and fulfilled (including detailed information found in manual subsections).

■ Licensed professional heating contractor

The installation, service, and maintenance of this equipment *must be* performed by a licensed professional heating contractor.

► Please see section entitled "Important Regulatory and Installation Requirements" in the Installation Instructions.

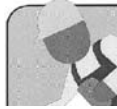

■ Product documentation

Read all applicable documentation before commencing installation. Store documentation in a readily accessible location for reference in the future by service personnel.

► For a listing of applicable literature, please see section entitled "Important Regulatory and Safety Requirements"



■ Advice to owner

Once the installation work is complete, the heating contractor must familiarize the system operator/ultimate owner with all equipment, as well as safety precautions/requirements, shut-down procedure, and the need for professional service annually.

■ Warranty

Information contained in this and related product documentation must be read and followed. *Failure to do so renders warranty null and void.*



■ Grounding/Lightning protection of the solar system

In the lower part of the building, install an electrical conductor on the piping system of the solar circuit in compliance with local regulations. Connection of the solar system to a new or existing lightning protection or the provision of local grounding should only be carried out by a licensed professional, who must take into account the prevailing conditions on site.

! CAUTION

Observe maximum load and distance from edge before installing the substructure to the roof. If necessary, consult with a structural engineer to determine if the structure is suitable for installing solar collectors. The collectors must be securely mounted so that the mountings can withstand intense wind conditions and local snow loads.

! CAUTION

Gloves and eye protection must be worn when handling solar panels.

! CAUTION

Solar panel connection pipes and solar heating fluid can become hot enough to cause severe burns. Extreme caution must be taken if panels have been in a stagnant condition (no flow of fluid).

! CAUTION

Avoid scratching or sudden shocks to glass cover of the solar panel.

! CAUTION

Never step on collectors or solder in close proximity to the glass surface of the solar panel.

■ Applicability

Vitosol solar collectors are designed for use in closed loop heating systems for domestic hot water heating, space heating and pool heating via a heat exchanger. The use of Viessmann heat transfer medium "Tyfocor-HTL" or equivalent is strongly recommended.

- In areas with extremely cold climate conditions, where outside temperatures may drop below -31° F (-35° C), the use of Tyfocor-HTL is not recommended. Use a solar propylene glycol mixture with a higher concentration of glycol that provides the level of freeze protection required for the area of the collector installation.

IMPORTANT

Pool water or potable water should not be pumped directly through the Vitosol collectors. Damage to collectors caused by corrosion, freezing or scaling will void warranty.

Safety	Safety, Installation and Warranty Requirements..... 2
	Important Regulatory and Installation Requirements..... 4
General Information	About these Installation Instructions..... 5
Start-up	Quick Start-Up Guide..... 6
	Start-up steps.....6
	Calculate and Set Expansion Tank Pre-Charge
	Pressure..... 7
	Calculate System Fluid Fill Pressure..... 8
	Fill, Flush and Leak Test the Solar
	Heating System..... 9
	Vent the Solar Heating System..... 10
	Check Switching Functions of the Solar Control Unit..... 10
	Check Electrical Connections..... 10
	Check Solar Fluid Flow Rate..... 11
Maintenance	Maintenance, Inspection and Cleaning..... 12
	Check Safety Equipment..... 13
	Shut Down Solar Heating System..... 13
	Clean Collectors..... 13
	Check Gaskets and Sealed Unions..... 13
	Check the Thermal Pipe Work Insulation..... 13
	Check Pumps..... 13
	Check Frost Protection Temperature of Heat
	Transfer Medium..... 14
	Check pH of Heat Transfer Medium..... 14
Additional Information	Parts List..... 15
	Technical Data..... 20
	System Fluid Calculator..... 21
	Maintenance Record..... 22

Important Regulatory and Installation Requirements

Initial start-up

Initial start-up must be performed by a qualified heating contractor. Completion of the Maintenance Record by the heating contractor is also required.

Note: See the Maintenance Record located on page 19.

Working on the equipment

The installation, adjustment, service and maintenance of this equipment must be done by a licensed professional heating contractor who is qualified and experienced in the installation, service and maintenance of hot water heating systems. There are no user serviceable parts on this equipment.

Note: Please carefully read this manual prior to attempting start-up, maintenance or service. Any warranty is null and void if these instructions are not followed. For information regarding other Viessmann System Technology componentry, please reference documentation of the respective product. Viessmann offers frequent installation and service seminars to familiarize our partners with our products. Please inquire.

Ensure main power supply to equipment, the heating system, and all external controls has been deactivated. Take precautions in all instances to avoid accidental activation of power during service work.

Note: The completeness and functionality of field supplied electrical controls and components must be verified by the heating contractor. These include low water cut-offs, flow switches (if used), staging controls, pumps, motorized valves, air vents, thermostats, etc.

Repair work

IMPORTANT

Repairing components which fulfil a safety function can compromise the safe operation of your heating system. Replace faulty components only with original Viessmann replacement parts. Ancillary components, spare and wear parts.

IMPORTANT

Replacement and wear parts which have not been tested together with the solar system can compromise its function. Installing non-authorized components and non-approved modifications/conversion can compromise safety and may infringe our warranty conditions. For replacement, use only original Viessmann replacement parts or those which are approved by Viessmann.

Instructing the system user

The installer of the system is responsible to ensure the system operator/ultimate owner is made familiar with the functioning of the system, its activation, and its shut-down.

Note: The following topics must be covered:
Proper system operation sequence. Explain the equipment. Demonstrate an emergency shut-down, what to do and what not. Explain that there is no substitute for proper maintenance to help ensure safe operation.

Technical literature

Literature applicable to all aspects of the Vitosol 100-F, 200-F or Vitosol 200-T:
- Technical Data Manual
- Installation Instructions
- Start-up, Service and Operating Instructions
- System Design Guidelines

Note: Leave all literature at the installation site and advise the system operator/ultimate owner where the literature can be found. Contact Viessmann for additional copies.

About these Installation Instructions



Take note of all symbols and notations intended to draw attention to potential hazards or important product information. These include "WARNING", "CAUTION", and "IMPORTANT". See below.



WARNING

Indicates an imminently hazardous situation which, if not avoided, could result in death, serious injury or substantial product/property damage.

► *Warnings draw your attention to the presence of potential hazards or important product information.*



CAUTION

Indicates an imminently hazardous situation which, if not avoided, may result in minor injury or product/property damage.

► *Cautions draw your attention to the presence of potential hazards or important product information.*

IMPORTANT

► *Helpful hints for installation, operation or maintenance which pertain to the product.*



► *This symbol indicates that additional, pertinent information is to be found.*



► *This symbol indicates that other instructions must be referenced.*

Quick Start-up Guide

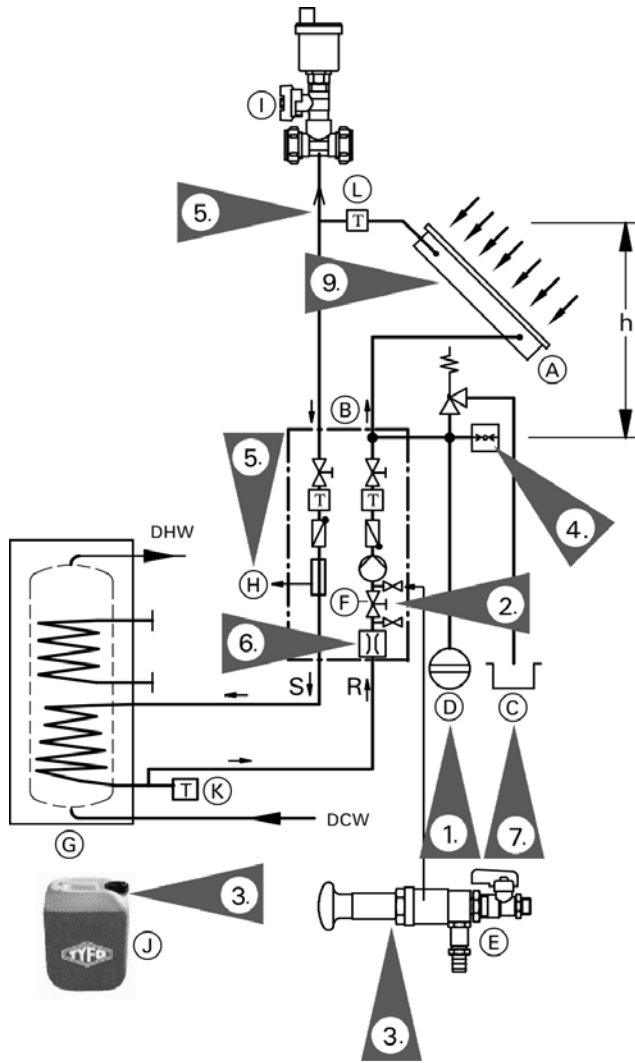

Legend

- (A) Solar collector
- (B) Solar-Divicon (pumping station)
- (C) Overflow container
- (D) Expansion vessel
- (E) Solar manual filling pump
- (F) System fill manifold
- (G) Solar storage tank
- (H) Air separator
- (J) Solar fluid
- (K) Tank temperature sensor
- (L) Collector temperature sensor
- h Static head (used to calculate system pressure).
Highest point in system to expansion tank connection.
- R Return to collector
- S Supply from collector

Start-up steps

1. Check and adjust nitrogen cushion pressure in the diaphragm expansion tank (D). Calculate cushion pressure based on formula (see page 7) and charge cushion pressure as required.
2. Thoroughly flush system through the system fill manifold (F) to remove debris and flux residue (see page 9).
3. Fill system with solar fluid (J) through the system fill manifold (F) using charge pump or hand fill pump (E).

CAUTION

Never mix Tyfocor HTL with alternative heat transfer media or with water.

4. Fill system to minimum fluid fill pressure (see page 8).
Typical values:
1-storey home = 25.5 psig / 1.7 bar
2-storey home = 30 psig / 2.1 bar
5. Purge all air from air vents (I) and (H) by running solar loop pump at maximum speed. After system is completely vented, shut off air vent valve in top of system (see page 10).
6. Set system flow rate (see page 11).
7. Provide overflow container (C) (minimum size should equal collector fluid volume).
8. Set control settings: Differentials, maximum tank temperature.
9. Remove protective film from flat plate collectors or install the tubes.

CAUTION

Remove protective film from flat plate collector **ONLY** after all above steps have been completed.

CAUTION

Never flush with water when it is freezing, if no heat transfer medium is used.

CAUTION

Never drain the system with a vacuum pump.

Calculate and Set Expansion Tank Pre-charge Pressure

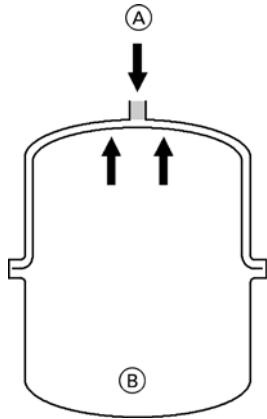

Delivered condition
(3 bar/45 psig pressure)

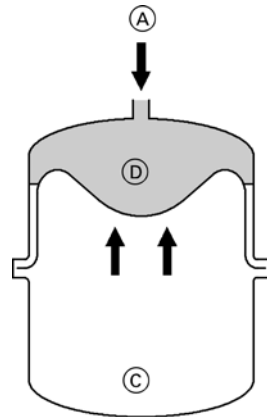

Solar heating system
filled without heat effect

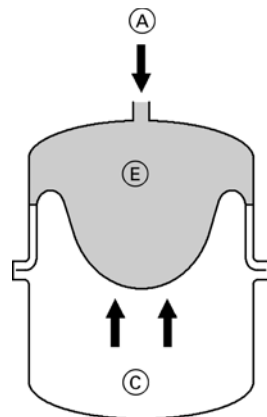

Under max. pressure at the
highest process medium temperature

1. Cover the collectors with tarpaulin (if necessary).
2. If the system has already been filled, release fluid to ensure the system pressure gage indicates 0 psi (bar), or isolate the expansion tank from the system using the service valves and reduce the fluid pressure at the expansion tank connection. For new installations, set tank pressure prior to filling the system.
3. Calculate the air cushion charge pressure of the expansion tank using this formula:

$$15 \text{ psig} + 0.45 \times \text{static head in ft.}$$

$$(1.0 \text{ bar} + 0.1 \times \text{static head in m})$$

Static head h (collector top edge to the expansion tank) = ____ ft. ____ (m)

$$= 15 \text{ psig} + 0.45 \times \text{____ ft.} = \text{____ psig}$$

$$= (1.0 \text{ bar} + 0.1 \times \text{____ m}) = \text{____ bar}$$

4. In most cases the precharge pressure of the diaphragm expansion tank as delivered from the factory (45 psig) will be higher than the calculated charge pressure. Remove sufficient nitrogen by releasing pressure through the air valve to ensure the precharge pressure equals the calculated value.

IMPORTANT

Record the "pre-charge pressure level" on the expansion tank for future reference.

Legend

- (A) Heat transfer medium
- (B) Nitrogen filling
- (C) Nitrogen buffer
- (D) Safety water seal, min. 0.8 USG (3 L).
- (E) Safety water seal under max. pressure

Calculate System Fluid Fill Pressure

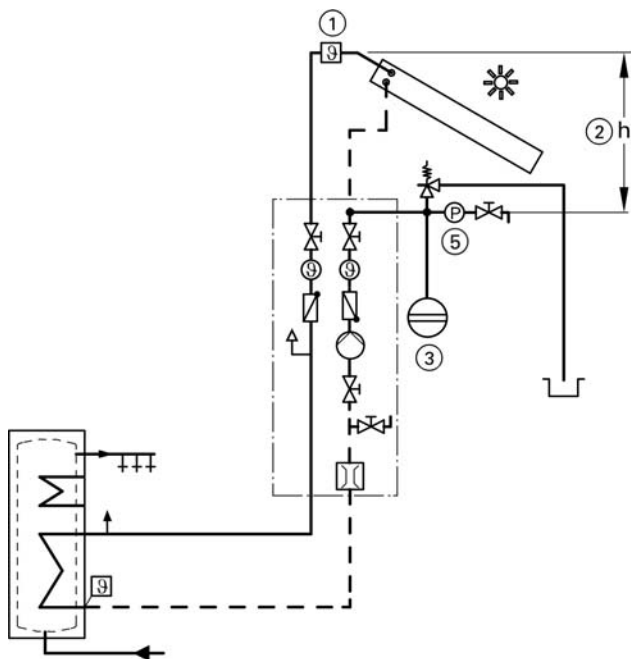

1. Calculate the system fluid fill pressure using the formula below. The fluid fill pressure must exceed the set air cushion charge pressure of the diaphragm expansion tank by 5 psig (0.4 bar). This additional pressure creates a safety water seal in the expansion tank (see middle picture on page 7). The safety water seal helps for ventilation and to ensure no steam can enter the expansion tank during stagnation.

The final system fluid fill pressure can be calculated using this formula:

$$15 \text{ psig} + 0.45 \times \text{static head (ft.)} + (5 \text{ psig})$$

or

$$1.0 \text{ bar} + 0.1 \times \text{static head (m)} + (0.4 \text{ bar}).$$

Typical fluid pressure examples:

1-story home, static head = 10 ft. (3 m)
System fill pressure = 25.5 psig / (1.7 bar)

2-story home, static head = 20 ft. (6 m)
System fill pressure = 30 psig (2.0 bar)

Pressure calculation worksheet

①	Minimum pressure at top of solar system	15 psig	1.0 bar
②	Additional static head pressure 0.45 psig x h (static head ft.) 0.1 bar x h (static head m) psig bar
③	Pre-charge pressure of the expansion tank (① + ②) psig bar
④	Additional safety water seal pressure	5 psig	0.4 bar
⑤	Final system fluid fill pressure (③ + ④) psig bar

Fill, Flush and Leak Test the Solar Heating System



CAUTION

All work on the solar circuit or the components of the solar heating system may only be carried out if the sky is very cloudy, early in the morning, in the evening or with covered collectors.

We recommend the system is only flushed with the specified heat transfer medium to prevent a mixing with residual water inside the system. Mixing would alter the level of frost protection.



Compact mobile charge station for flushing, venting and filling solar collectors.

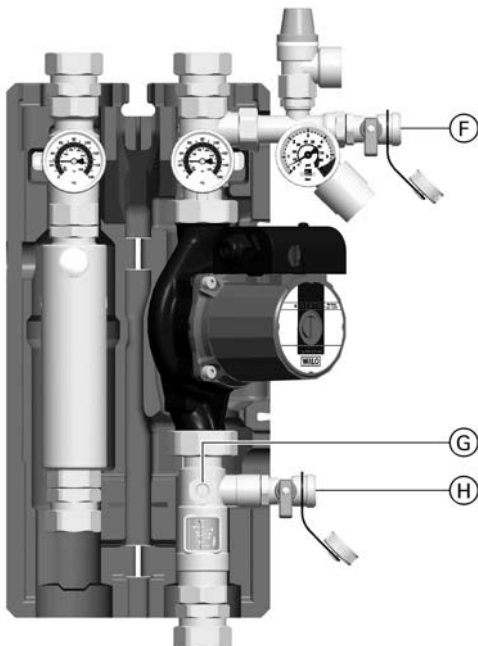

Solar-Divicon DN20B/DN25B pumping station

IMPORTANT

- Heat transfer media containing glycol can be damaged if they are subjected to temperatures above 338° F (170° C) for a prolonged period of time (stagnation). This can lead to the system suffering from sludge and hard deposits, particularly in conjunction with other contaminants and air.
 - Ensure that the system is correctly flushed, filled and vented after installation. After filling the system with heat transfer medium, ensure the system is correctly vented and that heat is transferred inside the system, i.e. that longer periods of stagnation are avoided.
 - The glycol PRV blow-off and drain pipe should terminate in an open container capable of holding the maximum possible collector fluid volume.
 - The Viessmann compact mobile charging station is highly recommended for fast effective flushing, filling and air removal.
1. Do not remove cover foil from flat plate collectors or install vacuum tubes before filling the system. Cover up collectors, if necessary.
 2. Manually open any installed isolation valves.
 3. Open the flow check valves on the Solar Divicon supply and return lines by: Turning the thermometers clockwise 45°.
 4. Close the shut-off valve (G) on the system fill manifold and open the drain valve (H).
 5. The system is flushed via the return line to the collector. Fill and flush the system with heat transfer medium via the filling valve (F). Flush using a quick-running pump until you can be sure that all debris and air has been purged from the solar panel system. Proper start-up can only be guaranteed with a system that is completely free of air.
 6. Close the drain valve (H) on the system fill manifold. Continue to charge system until desired final fill pressure is achieved (see page 8), then close (F). Open the shut-off valve (G) and check the system for leaks. Manually operate the Solar-Divicon pump at maximum speed for at least one hour to purge any remaining air. Observe the permissible operating pressure. The pressure should not drop over the space of at least one hour. Please refer to the Installation, Start-up and Service Instruction Manual for the Solar-Divicon for additional information.
 7. Set the pump speed as required to obtain the flow rate shown in the chart on page 11.

Vent the Solar Heating System

1. The flow check valves on the Solar Divicon can be bypassed by turning the thermometer valve 45°. Leave them in this position while starting up system. Open the air vent valve at the top of the system and bleed air from the air separator in the Solar Divicon.
2. Adjust the circulation pump to its highest speed setting, and vent by starting and stopping several times (a vented pump will operate almost silently).
Note: Even after thorough ventilation, some dissolved air will still remain in the heat transfer medium. This will be released as the temperature rises, and will be discharged via the air separator.
3. Repeat the venting step until the float in the flow meter of Solar Divicon holds a steady position when the pump is running (highest speed setting).
Note: If present air bubbles will be visible in the flow meter (float moves).
4. Adjust the flow rate via the speed selector switch of the circulation pump. See page 11 for suggested flow settings for different collector arrays.
5. Repeat the venting steps after the system has been operating a few days.

IMPORTANT

Top up with heat transfer medium and repeat the venting process with the system in its cold state, if the system pressure has dropped after venting.

6. Close the air vent valve at the top of the collectors after system venting is complete.
7. Periodically bleed air from manual air separator on the Solar Divicon until no air is visible.



CAUTION

Failure to close air vent at top of system can lead to steam escaping from air vent.

Check Switching Functions of the Solar Control Unit



Refer to the Installation Instructions of the solar control unit.

Check Electrical Connections

Check the tightness of electrical connections and cable grommets.
Check the cables for possible damage.

Check Solar Fluid Flow Rate

Flow Rate - Vitosol 100-F / 200-F

Vitosol 100-F / 200-F recommended flow rates *Applies to both SV and SH models	High flow mode USG/min (L/min)	Medium flow mode USG/min (L/min)	Low flow mode USG/min (L/min)
1 collector	0.61 (2.32)	--	--
2 collectors	1.22 (4.6)	--	--
3 collectors	1.83 (6.9)	--	--
4 collectors	2.44 (9.2)	--	--
5 collectors	3.05 (11.5)	--	--
6 collectors	3.66 (13.8)	--	--
7 collectors	--	3.15 (12.2)	2.17 (8.1)
8 collectors	--	3.6 (13.6)	2.48 (9.4)
9 collectors	--	4.05 (15.7)	2.79 (10.4)
10 collectors	--	4.5 (17.0)	3.1 (11.7)
11 collectors	--	4.95 (19.1)	3.41 (12.8)
12 collectors	--	5.4 (20.8)	3.72 (14.1)

Note: Maximum of 10 Vitosol-F can be connected in one array with same side piping connections.
Maximum of 12 Vitosol-F can be connected in one array with opposite side connections.

Flow Rate Vitosol 200-T, SPE

Vitosol 200-T, SPE recommended flow rates	High flow mode USG/min (L/min)	Medium flow mode USG/min (L/min)	Low flow mode USG/min (L/min)
9 tube collector array model 1.63 m ²	0.47 (1.8)	--	--
18 tube collector array model 3.26 m ²	0.95 (3.6)	--	--
27 tube collector array*	1.4 (5.4)	--	--
36 tube collector array*	1.9 (7.2)	--	--
45 tube collector array*	2.4 (9.0)	--	--
54 tube collector array*	2.9 (10.8)	--	--
72 tube collector array*	--	2.8 (10.6)	--
90 tube collector array*	--	3.5 (13.3)	2.7 (10.0)
108 tube collector array*	--	--	3.2 (12.0)

* Collector arrays are combinations of collector model 1.63 m² and/or model 3.26 m².

Note: Maximum of 108 SPE tubes can be connected in one array.

Flow Rate Vitosol 200-T, SP2A

Vitosol 200-T, SP2A recommended flow rates	High flow mode USG/min (L/min)	Medium flow mode USG/min (L/min)	Low flow mode USG/min (L/min)
10 tube collector array model 1.26 m ²	0.55 (2.1)	--	--
12 tube collector array model 1.51 m ²	0.6 (2.3)	--	--
24 tube collector array model 3.03 m ²	0.86 (3.3)	--	--
36 tube collector array*	1.46 (5.6)	--	--
48 tube collector array*	1.72 (6.6)	--	--
60 tube collector array*	2.32 (8.9)	--	--
72 tube collector array*	2.58 (9.9)	2.01 (7.5)	--
84 tube collector array*	--	2.41 (9.0)	--
96 tube collector array*	--	2.68 (10.0)	1.9 (7.2)

* Collector arrays are combinations of collector model 1.51 m² and/or model 3.03 m².

Note: Maximum of 96 SP2A tubes can be connected in one array.

Maintenance, Inspection and Cleaning

The solar thermal system must be inspected regularly by the building owner to verify that the control is operational, and that the solar pump is running when the sun is shining and that the system fluid pressure is within range.



CAUTION

The building owner must notify a qualified heating contractor immediately if they notice any problems with the solar control or solar pump, or a system pressure drop. Failure to do so can result in system stagnation leading to excessively high temperatures and damage to the solar fluid and or system components.

The solar thermal system should be inspected **once a year** by a qualified heating contractor to ensure operational reliability.

In addition to this, a visual inspection of all essential components (e.g. collectors and pipe work) is recommended every 3 to 5 years.

Regular inspection and service by a qualified heating contractor is critical to the performance of the Viessmann Vitosol 100-F, 200-F and 200-T. Neglected maintenance, e.g. forgoing regular cleaning services, impacts on warranty and will result in decreased efficiency of the system. Regular cleaning and maintenance ensures clean, environmentally friendly and efficient operation. We recommend a maintenance contract with a qualified heating contractor.

Regular maintenance required:

- Keep collectors clean
- Check integrity of collector roof mounting hardware
- Check the thermal insulation of the pipes for positioning and damage and adjust if required
- Regularly check the pressure gage
- Compare the system operating pressure with the set value. If values are different, check the expansion tank (see page 7)
- Bleed air from air separator on Solar-Divicon.
- Have any leaks repaired immediately by a heating contractor
- After approximately six months the following functions should be tested:
 - operating pressure
 - smooth running of the pump(s)
 - supply temperatures
 - control functions
- Check freezing point and pH of the heat transfer medium annually
- After five years, the storage tank heat exchanger should be inspected
- For Vitocell 100 tanks, check and replace magnesium anode every two years



Refer to the Vitocell 100 Service Instructions.

Check Safety Equipment

Check for proper operation of all safety equipment take into account local jurisdiction.

Shut Down Solar Heating System

IMPORTANT

Shut down of the solar system must always be avoided when the sun is shining on the collectors. If possible only shut down the system on cloudy days or in the morning or evening. If the sun is shining on the collectors, they must be covered before any work on the components of the solar heating system begins, in order to prevent equipment damage.

Isolate the main power supply of the system (e.g. by unplugging the control system or by means of a main power disconnect switch) and safeguard against unauthorized and/or accidental reactivation.

Clean Collectors

In areas experiencing frequent rain, collector cleaning is not usually required. In areas with very dry climates, urban areas or dusty areas, check and clean collectors periodically.

Use a glass cleaner or soap and water solution and rinse thoroughly with water.

Check Gaskets and Sealed Unions

Replace all worn/faulty parts.

Check the Thermal Pipe Work Insulation

Check the thermal insulation of the pipe work for damage and fit. No bare metal or fiberglass insulation should be exposed. Adjust if necessary. Replace all worn/faulty parts.

IMPORTANT

The thermal insulation of external pipe work must be resistant to temperature, water and UV radiation. It must be protected against destruction by small animals and birds (e.g. metal jacketing).

Check Pumps

Check for proper operation of circulation pumps

Check Frost Protection Temperature of Heat Transfer Medium

Tyfoacor HTL should be between 45-50% propylene glycol. See below or for more details, refer to the product MSDS information on Tyfoacor.

CAUTION

In areas with extremely cold climate conditions, where outside temperatures may drop below -31°F (-35°C), the use of Tyfoacor-HTL is not recommended. Use a solar propylene glycol mixture with a higher concentration of glycol that provides the level of freeze protection required for the area of the collector installation.

Check the freezing point of Tyfoacor HTL heat transfer medium with a Viessmann frost protection tester, or approved alternate refractometer.

CAUTION

Never mix Tyfoacor HTL with water or alternate heat transfer fluid.

CAUTION

Failure to test frost protection temperature of solar fluid can lead to freezing and damage to collector.

Check pH of Heat Transfer Medium

The Tyfoacor heat transfer medium supplied is a liquid based on 1.2 - propylene glycol with a frost protection limit of -31°F (-35°C). Below this temperature the fluid is no longer pumpable.

The heat transfer fluid can be damaged if exposed to long periods of stagnation. The pH level of the fluid is the indicator of the fluids suitability for continued use. The pH value should be in the range of 7.5 - 10. This must be tested annually. If the pH value falls below 7.5, the heat transfer fluid must be drained, flushed and refilled with the new fluid.

CAUTION

Failure to test pH and replace solar fluid as required can lead to corrosion and fouling of collector circuit.

Parts List

Vitosol 100-F and 200-F SV1B / SV2C / SH1B / SH2C Series

Ordering Replacement Parts:

Please provide Model and Serial Number from rating plate when ordering replacement parts. Order replacement components from your Viessmann distributor.

Parts

- 001 Interconnection pipe
- 002 Connection pipe (short)
- 003 Connection pipe (long)
- 004 Pipe plug
- 005 Compression connector (straight)
- 006 Compression connector (elbow)
- 007 Clip for assembly kit
- 008 Connection element
- 009 Installation plate
- 010 Spacer plug
- 011 Support plate
- 012 O-ring set (Set of 4)
- 013 Retaining screw (Set of 3)
- 014 Profile clamp
- 015 Diagonal (foam) strip
- 016 Support tube, 22 x 1

Other Parts (not illustrated)

- 020 Lubricating grease, 6g
- 100 Installation Instructions
- 101 Operating / Service Instructions
- 102 Parts List
- 103 Warranty Sheet

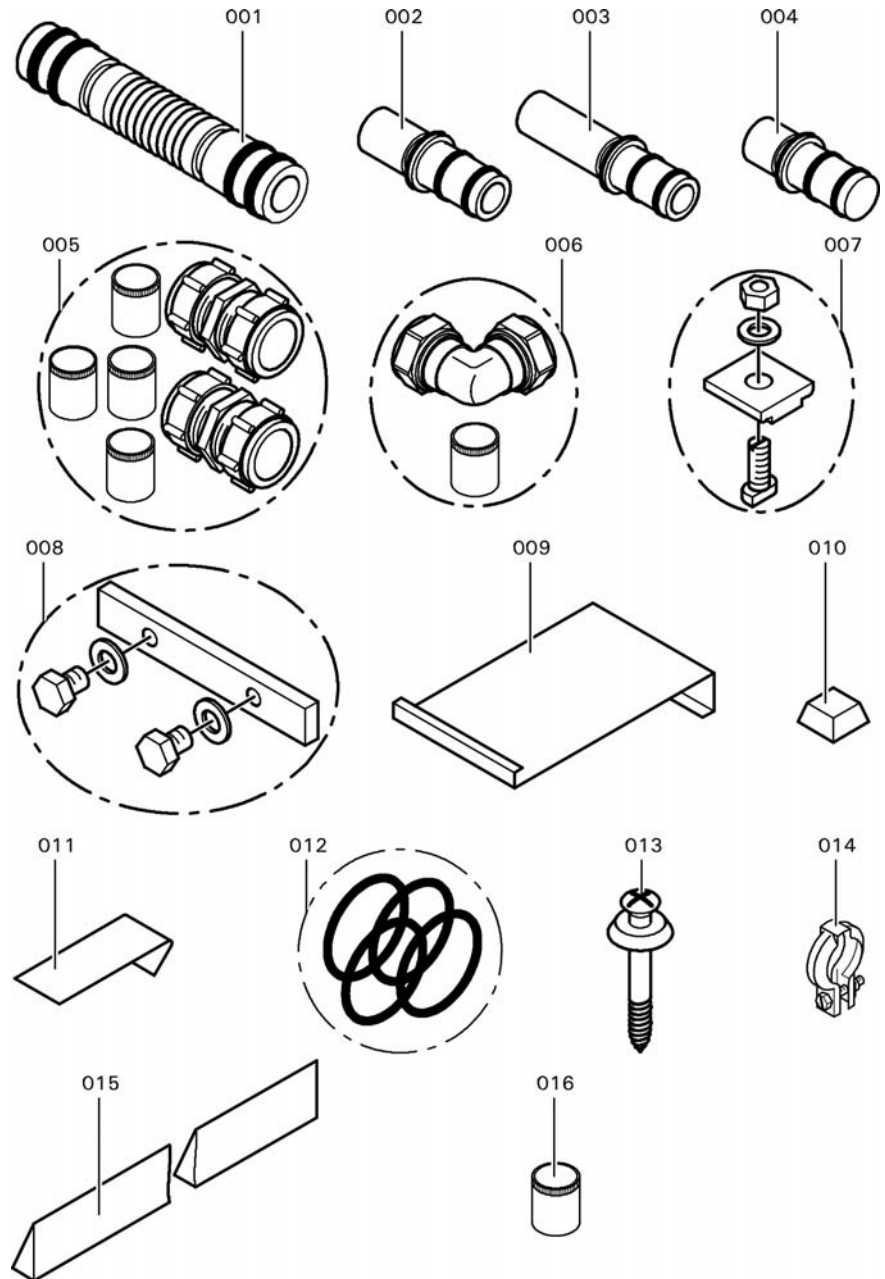

Parts List *(continued)*

**Vitosol 200-T
SPE Series**

Ordering Replacement Parts:

Please provide Model and Serial Number from rating plate when ordering replacement parts. Order replacement components from your Viessmann distributor.

Parts

- 001 Vacuum tube
- 002 Tube retainer
- 003 Collector fastening
- 004 Clamping rings
- 005 O-rings
- 006 Clamping bracket, complete
- 007 Connection pipe
- 008 Support sleeve
- 009 Special valve grease
- 010 Elbow fitting with support sleeve
- 011 Connection pipe with thermal insulation
- 012 Mounting bracket for sheet steel roofs, complete
- 013 Fixing pin
- 014 Locking bracket
- 015 Mounting bracket for horizontal installation, complete
- 016 Dismantling instructions
- 017 Installation instructions
- 018 Service instructions
- 019 Operating instructions
- 020 Seal ring, side cover
- 021 Side cover, R. H.
- 022 Pipe gasket
- 023 Cap
- 024 Side cover, L. H.

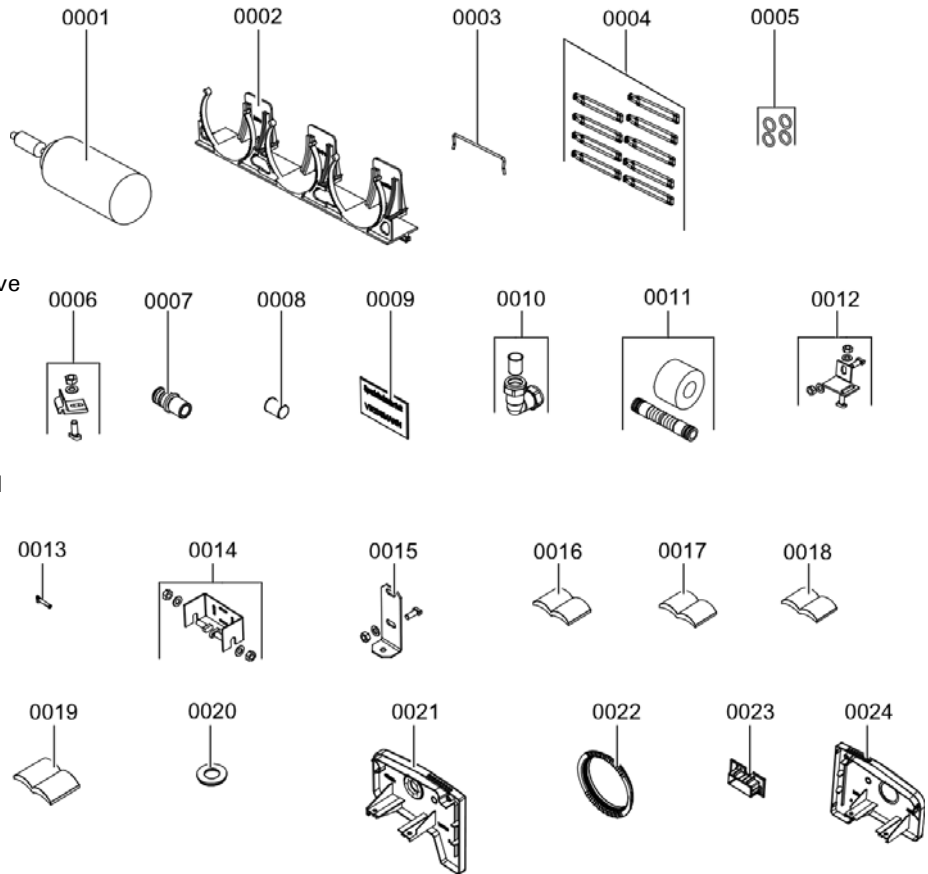

Parts List *(continued)*

**Vitosol 200-T
SP2A Series**

Ordering Replacement Parts:

Please provide Model and Serial Number from rating plate when ordering replacement parts. Order replacement components from your Viessmann distributor.

Parts

- 0001 Vacuum tube
- 0002 Tube cap
- 0003 Tube retainer
- 0004 Clamping rings
- 0005 Spring clips
- 0006 O-rings
- 0007 Collector fastening
- 0008 Connection pipe (short)
- 0009 Connection pipe (long)
- 0010 Special valve grease
- 0011 Clamping bracket
- 0012 Elbow fitting with support sleeve
- 0013 Connection pipe with thermal insulation
- 0014 Bend
- 0015 Bend with air vent valve
- 0016 Support sleeve
- 0017 Mounting bracket for sheet steel roof
- 0018 Locking bracket
- 0019 Mounting bracket for horizontal installation
- 0020 Dismantling instructions
- 0021 Installation instructions
- 0022 Service instructions
- 0023 Operating instructions
- 0024 Thermal insulation cap
- 0025 Fixing pins for side cover
- 0026 Side seal
- 0027 Pipe gasket
- 0028 Cap
- 0029 Security clip for connection pipes

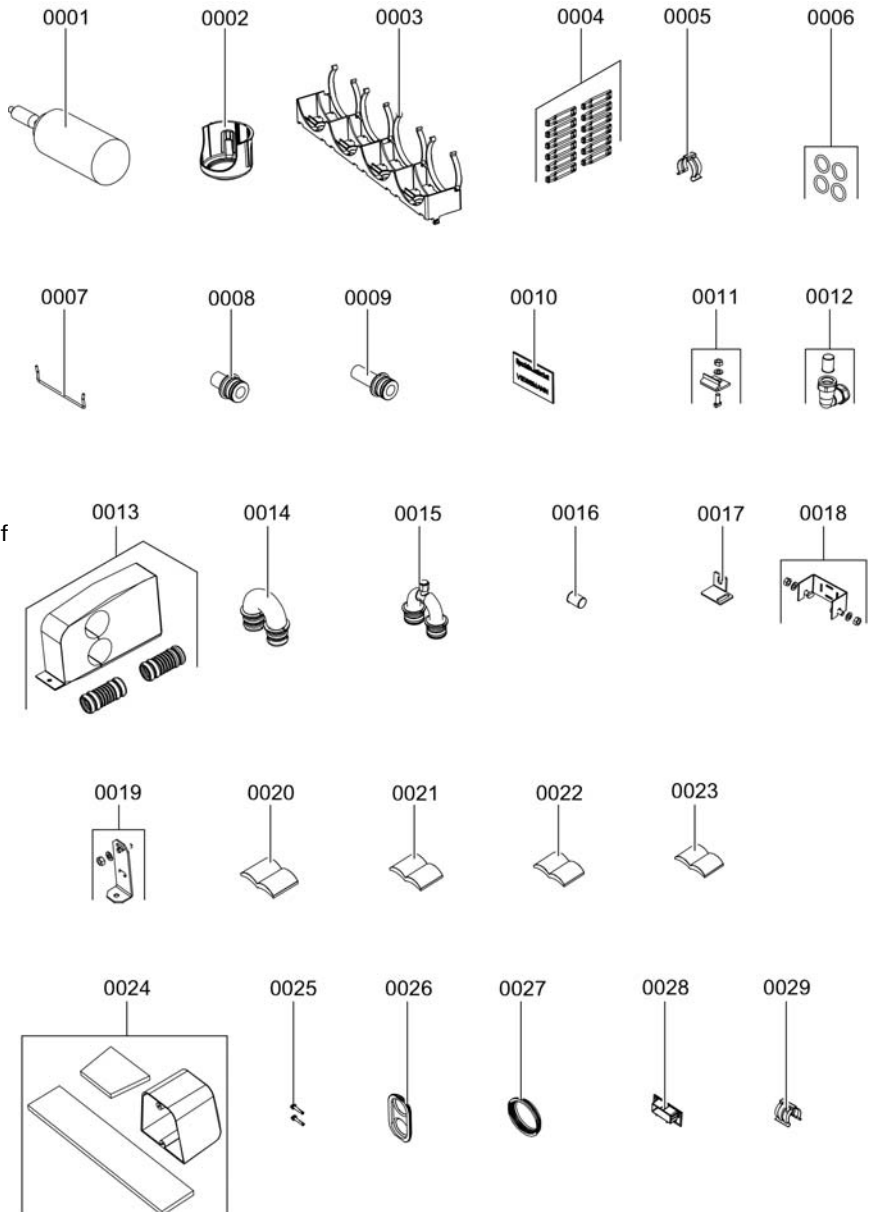

Parts List *(continued)*

Installation Fittings,

7427 617, 7533 717, 5533 718
for VITOSOL solar collectors

Ordering Replacement Parts:

Please provide Model and Serial Number from rating plate when ordering replacement parts. Order replacement components from your Viessmann distributor.

Parts

- 001 Copper pipe adaptor, 3/4" x 4"
- 002 Copper pipe, Ø 22 l=60mm
- 003 Adaptor 3/4" G female - 3/4" NPT male
- 004 Gasket, A 17.2 x 23.9 x 1.5

Other Parts (not illustrated)

- 0401 Technical literature set
- 0402 Parts List

Overview of Componentry

(outside of installation fittings)

- (A) Vitosol-F Collector
see separate Parts List
- (B) Vitosol 200-T, SPE collector
see separate Parts List
- (C) Vitosol 200-T, SP2A collector
see separate Parts List
- (D) Solar Expansion Tank
- (E) Short connection pipe *1
For Vitosol 100-F / 200-F only
- (F) Long connection pipe *1
For Vitosol 100-F / 200-F only
- (G) Fast air vent *2
- (H) 90° compression elbow
- (I) Sensor well set
For Vitosol 100-F / 200-F only
- (K) 1" NPT male to copper sweat adaptor
- (L) Short connection pipe *1
For Vitosol 200-T, SP2A only
- (M) Long connection pipe *1
For Vitosol 200-T, SP2A only
- (N) Short connection pipe *1
For Vitosol 200-T, SPE only

*1 Included with general connection set

*2 Sold separately - see price list

*3 Field Supplied

Vitosol 100-F / Vitosol 200-F

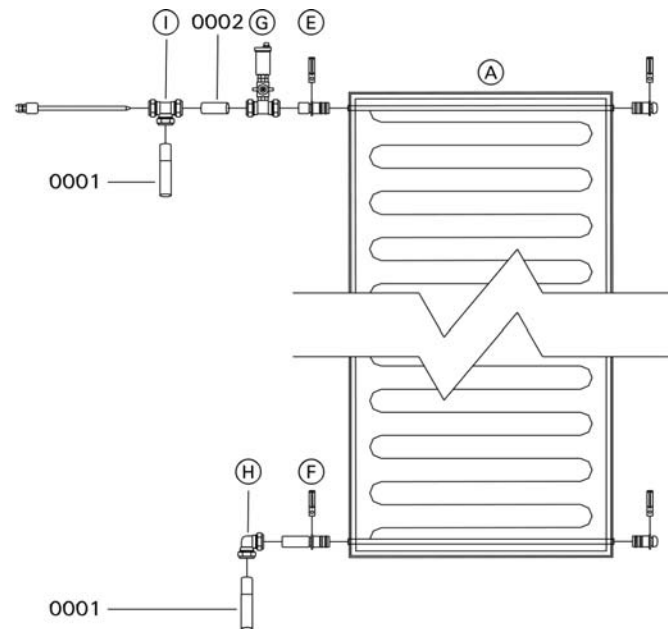

Vitosol 200-T, SPE Series

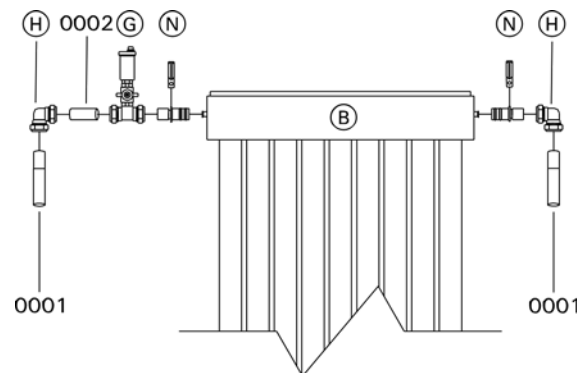

Vitosol 200-T, SP2A Series

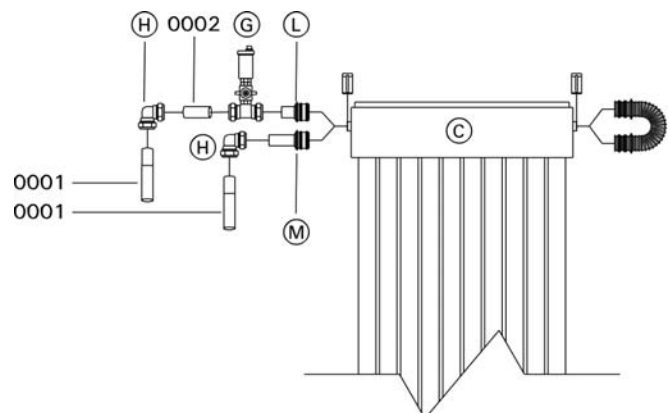

Parts List *(continued)*

Installation Fittings,

7427 617, 7533 717, 5533 718
for VITOSOL solar collectors

Parts

- 001 Copper pipe adaptor, 3/4" x 4"
- 002 Copper pipe, Ø 22 l=60mm
- 003 Adaptor
3/4" G female - 3/4" NPT male
- 004 Gasket,
A 17.2 x 23.9 x 1.5

Other Parts (not illustrated)

- 0401 Technical literature set
- 0402 Parts List

Solar Expansion Tanks

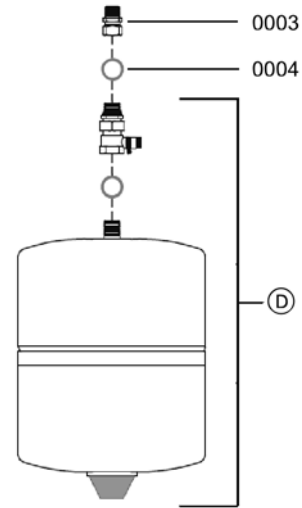

18L, 25L, 40L and 50L Tank

Overview of Componentry

(outside of installation fittings)

- (D) Solar Expansion Tank
- (K) 1" NPT male to copper sweat adaptor

*3 Field Supplied

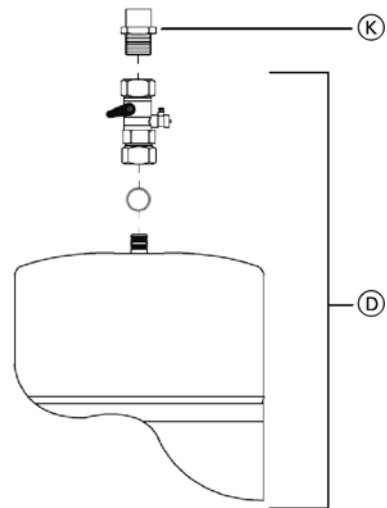

80L Tank

Technical Data

Vitosol 100-F

Model		SV1B	SH1B
Gross area	ft. ² (m ²)	27.0 (2.51)	27.0 (2.51)
Absorber area	ft. ² (m ²)	25.0 (2.32)	25.0 (2.32)
Aperture area	ft. ² (m ²)	25.1 (2.33)	25.1 (2.33)
Max. stagnation temperature	°F (°C)	395 (196)	395 (196)
Permiss. operating pressure	psig (bar)	87 (6)	87 (6)
Liquid content	USG (L)	0.44 (1.67)	0.62 (2.33)

Vitosol 200-F

Model		SV2C	SH2C
Gross area	ft. ² (m ²)	27.0 (2.51)	27.0 (2.51)
Absorber area	ft. ² (m ²)	25.0 (2.32)	25.0 (2.32)
Aperture area	ft. ² (m ²)	25.1 (2.33)	25.1 (2.33)
Max. stagnation temperature	°F (°C)	367 (186)	367 (186)
Permiss. operating pressure	psig (bar)	87 (6)	87 (6)
Liquid content	USG (L)	0.48 (1.83)	0.65 (2.48)

Vitosol 200-T

Model		SPE 1.63m ²	SPE 3.26m ²
# of tubes per collector		9	18
Gross area	ft. ² (m ²)	28.63 (2.66)	57.26 (5.32)
Absorber area	ft. ² (m ²)	17.55 (1.63)	35.10 (3.26)
Aperture area	ft. ² (m ²)	18.84 (1.75)	37.57 (3.49)
Max. stagnation temperature	°F (°C)	518 (270)	518 (270)
Permiss. operating pressure	psig (bar)	87 (6)	87 (6)
Liquid content	USG (L)	0.124 (0.47)	0.243 (0.92)

Vitosol 200-T

Model		SP2A 1.26m ²	SP2A 1.51m ²	SP2A 3.03m ²
# of tubes per collector		10	12	24
Gross area	ft. ² (m ²)	21.31 (1.98)	25.40 (2.36)	49.73 (4.62)
Absorber area	ft. ² (m ²)	13.56 (1.26)	16.25 (1.51)	32.61 (3.03)
Aperture area	ft. ² (m ²)	14.32 (1.33)	17.22 (1.60)	34.33 (3.19)
Max. stagnation temperature	°F (°C)	558 (292)	558 (292)	558 (292)
Permiss. operating pressure	psig (bar)	87 (6)	87 (6)	87 (6)
Liquid content	USG (L)	0.2 (0.75)	0.22 (0.87)	0.4 (1.55)

System Fluid Calculator

Solar Components	Quantity / Item	Liquid Content / Item in Liters	Total Liquid Content in Liters
Expansion Tank Safety Cushion		x 3.00 =	
Vitosol 100-F, SV1B		x 1.67 =	
Vitosol 100-F, SH1B		x 2.33 =	
Vitosol 200-F, SV2C		x 1.83 =	
Vitosol 200-F, SH2C		x 2.48 =	
Vitosol 200-T, SP2A 1.26m ² (10x Tubes)		x 0.75 =	
Vitosol 200-T, SP2A 1.51m ² (12x Tubes)		x 0.87 =	
Vitosol 200-T, SP2A 3.03m ² (24x Tubes)		x 1.55 =	
Vitosol 200-T, SPE 1.63m ² (9x Tubes)		x 0.47 =	
Vitosol 200-T, SPE 3.26m ² (18x Tubes)		x 0.92 =	
Vitosol 200-F, SVK		x 1.27 =	
Solar Divicon, DN20		x 0.30 =	
Solar Divicon, DN25		x 0.30 =	
Solar Divicon, DN20B		x 0.30 =	
Solar Divicon, DN25B		x 0.50 =	
Solar Divicon-HX, DN20		x 0.98 =	
Solar Divicon-HX, DN25		x 1.20 =	
Vitocell 100-W, CVBA - 66 USG (250 L)		x 6.50 =	
Vitocell 100-W, CVSA - 69 USG (260 L)		x 6.50 =	
Vitocell 100-V, CVA - 42 USG (160 L)		x 5.50 =	
Vitocell 100-V, CVA - 53 USG (200 L)		x 5.50 =	
Vitocell 100-V, CVA - 79 USG (300 L)		x 10.00 =	
Vitocell 100-V, CVA - 119 USG (450 L)		x 12.50 =	
Vitocell 300-V, EVI - 53 USG (200 L)		x 10.00 =	
Vitocell 300-V, EVI - 79 USG (300 L)		x 11.00 =	
Vitocell 300-V, EVI - 119 USG (450 L)		x 15.00 =	
Vitocell 100-B, CVB - 79 USG (300 L)		x 10.00 =	
Vitocell 100-B, CVB - 119 USG (450 L)		x 12.50 =	
Vitocell 300-B, EVB - 79 USG (300 L)		x 11.00 =	
Vitocell 300-B, EVB - 119 USG (450 L)		x 15.00 =	
Vitocell 300-H, EHA - 92 USG (350 L)		x 13.00 =	
Vitocell 300-H, EHA - 119 USG (450 L)		x 16.00 =	
Solar Piping	Total Length in ft.	Liquid Content / ft. in Liters	Total Liquid Content in Liters
1/2" Copper		x 0.05 =	
3/4" Copper		x 0.10 =	
1" Copper		x 0.17 =	
1 1/4" Copper		x 0.26 =	
1 1/2" Copper		x 0.36 =	
1/2" Insulated Stainless Steel Piping Kit *		x 0.08 =	
Total Liquid Content of System in Liters (Solar Components + Solar Piping)			
Total Liquid Content of System in USG (Total Liquid Content of System in Liters ÷ 3.785 =USG)			

Note: Use this table to calculate the required amount of liquid content required for the solar thermal system.

- 1) Input the quantities for each listed item and the length of piping (in ft.) used in the system. Then multiply each item by the liquid content listed for each item and input each item total in the Total Liquid Content column.
- 2) Add all of the individual liquid content totals to determine the total liquid content of the system.

* This piping kit comes in 20 ft., 40 ft. and 50 ft. lengths (it combines two pipes for supply and return wrapped in foam insulation). Example: A 20 ft. piping kit contains 20 ft. of supply and 20 ft. of return with a total length of 40 ft.

Maintenance Record

	Maintenance/Service	Maintenance/Service	Maintenance/Service	Maintenance/Service	Maintenance/Service
on:					
by:					

	Maintenance/Service	Maintenance/Service	Maintenance/Service	Maintenance/Service	Maintenance/Service
on:					
by:					

	Maintenance/Service	Maintenance/Service	Maintenance/Service	Maintenance/Service	Maintenance/Service
on:					
by:					

	Maintenance/Service	Maintenance/Service	Maintenance/Service	Maintenance/Service	Maintenance/Service
on:					
by:					

	Maintenance/Service	Maintenance/Service	Maintenance/Service	Maintenance/Service	Maintenance/Service
on:					
by:					

	Maintenance/Service	Maintenance/Service	Maintenance/Service	Maintenance/Service	Maintenance/Service
on:					
by:					

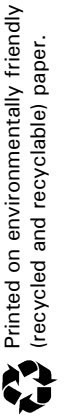

Printed on environmentally friendly
(recycled and recyclable) paper.

Technical information subject to change without notice.

Viessmann Manufacturing Company Inc.
750 McMurray Road
Waterloo, Ontario • N2V 2G5 • Canada
TechInfo Line 1-888-484-8643
1-800-387-7373 • Fax (519) 885-0887
www.viessmann.ca • info@viessmann.ca

Viessmann Manufacturing Company (U.S.) Inc.
45 Access Road
Warwick, Rhode Island • 02886 • USA
TechInfo Line 1-888-484-8643
1-800-288-0667 • Fax (401) 732-0590
www.viessmann-us.com • info@viessmann-us.com