

Technical Data Manual

Model Nos. and pricing: see Price List

VIESSMANN®

Vitodens 100-W

B1HA Series and B1KA Combi Boiler

Wall-Mounted, gas-fired condensing boilers

On demand domestic hot water with Combi boiler

Heating input: 21 to 125 MBH

6.2 to 36.6 kW



VITODENS® 100-W



Gas-Fired Wall-Mounted Condensing Boiler with modulating stainless steel Matrix cylinder burner, stainless steel Inox-Radial heat exchanger for room air independent operation (using a direct vent system) or room air dependent operation. B1KA comes equipped with an on demand hot water unit providing reliable hot water without a DHW tank.



Product Information

Equipped with a Viessmann stainless steel heat exchanger for lasting performance and reliability and a modulating MatriX cylinder gas burner, the Vitodens 100-W wall-mounted condensing boiler is the perfect combination of value, quality and Viessmann technology.

The benefits at a glance:

- **Outstanding efficiency**
of 95.0% A.F.U.E. on all models.
- **Lasting performance**
with Viessmann-made SA240 S43932 stainless steel Inox-Radial heat exchanger constructed to ASME Section IV and CSA B51.
- **Low-emission**
with fully-modulating stainless steel MatriX cylinder burner. Factory calibration eliminates adjustments in the field.
< 45 ppm NO_x (at 3% O₂)
- **Control variety**
Integrated boiler control interfaces with any level of external control - from room thermostat to outdoor reset and more.
- **Compact, lightweight wall mount design**
and zero clearance to combustibles make it a great choice for limited-space installations.
- **Extremely quiet operation**
quieter than most refrigerators.
< 52 dBA [at 3.3 ft. (1 meter)]
- **Easy installation, service and maintenance**
with all pipe connections located at the bottom and serviceable components (including electrical connections) easily accessible from the front.
- **Multiple venting options**
 - Horizontal or vertical sealed combustion coaxial, PP(s) vent system (Viessmann supplied).
 - Horizontal, vertical or hybrid sealed combustion double-pipe CPVC vent system (field supplied).
 - Horizontal or vertical single pipe CPVC vent system (field supplied).
 - Horizontal or vertical single or double pipe PP(s), flexible vent system (Viessmann supplied).
- **Suitable for high altitude levels**
of up to 10,000 ft. (3,000 m).
- **Built-in automatic frost protection**
allows boiler to be shut off for an extended period of time while protecting it against freeze-up.
- **Reliable on demand domestic hot water (B1KA)**
 - Plate type heat exchanger
 - Built-in diverting valve
 - Built-in Grundfos 3-speed pump
 - Built-in pressure bypass valve
 - Built-in water hammer arrester
 - Built-in flow sensor
 - Built-in temperature sensor
 - Supplied with a pressure relief valve rated at 150 psi
- **Limited lifetime warranty**
in residential applications.
- The B1KA boiler conforms to NSF/ANSI 372 for “lead free” plumbing products as defined by applicable US state laws and by section 1417 of the US Safe Drinking Water Act.

Product Information

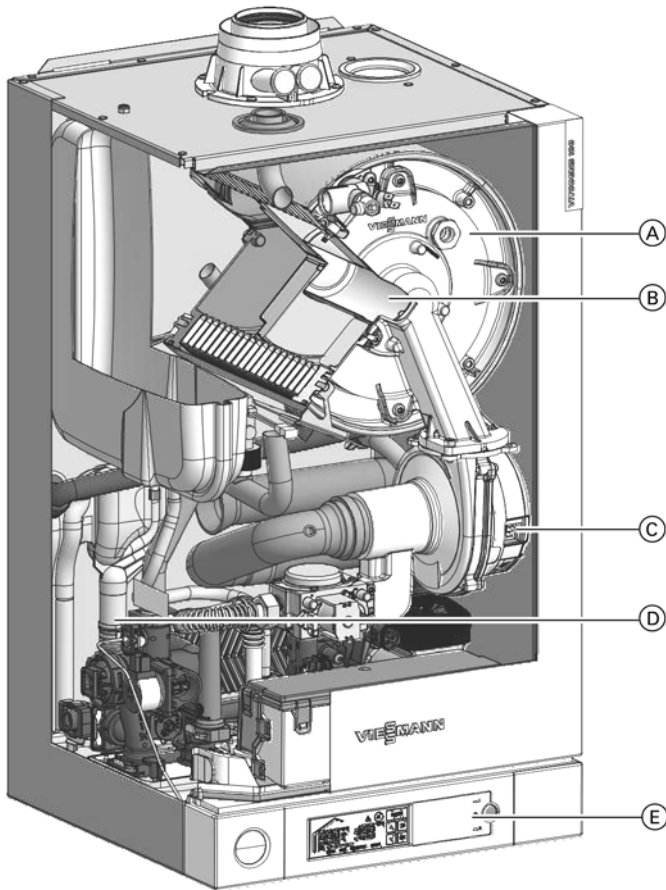

Standard Equipment:

Wall-mount boiler and installation fittings c/w 30 psi pressure relief valve, pressure gage, gas shut-off valve, two fill/drain valves, all mounting hardware, outdoor temperature sensor, and LP conversion kit.

Boiler cross-section

Legend

- Ⓐ Inox-Radial stainless steel heat exchanger
- Ⓑ Stainless steel MatriX cylinder burner
- Ⓒ Burner blower
- Ⓓ Gas and hydronic connections
- Ⓔ Boiler control

Specifications

Standard heating boiler

| | Boiler Model No. | B1HA 26, 94 | B1HA 35, 125 | B1KA 35, 125 |
|--|------------------|----------------------|--------------|--------------|
| CSA input Natural gas (NG) | MBH | 21-94 | 21-125 | 21-125 |
| | kW | 6.2-27.5 | 6.2-36.6 | 6.2-36.6 |
| CSA input Liquid propane Gas (LPG) | MBH | 31-94 | 31-125 | 31-125 |
| | kW | 9.1-27.5 | 9.1-36.6 | 9.1-36.6 |
| CSA output/DOE ¹ heating capacity NG | MBH | 20-87 | 20-116 | 20-116 |
| | kW | 5.7-25.6 | 5.7-34.1 | 5.7-34.1 |
| CSA output/DOE ¹ heating capacity LPG | MBH | 29-87 | 29-116 | 29-116 |
| | kW | 8.4-25.6 | 8.4-34.1 | 8.4-34.1 |
| Net AHRI rating ² | MBH | 76 | 101 | 101 |
| Heat exchanger surface area | ft. ² | 12.96 | 12.96 | 12.96 |
| | m ² | 1.2 | 1.2 | 1.2 |
| Min. gas supply pressure | | | | |
| Natural gas | "w.c. | 4 | 4 | 4 |
| LPG | "w.c. | 10 | 10 | 10 |
| Max. gas supply pressure ³ | | | | |
| Natural gas and LPG | "w.c. | 14 | 14 | 14 |
| A.F.U.E. | % | 95.0 | 95.0 | 95.0 |
| Weight | lbs | 79.4 | 79.4 | 90.0 |
| | kg | 36 | 36 | 41 |
| Shipping weight | lbs | 88.2 | 88.2 | 99.2 |
| | kg | 40 | 40 | 45 |
| Boiler water content | USG | 1.02 | 1.02 | 1.02 |
| | L | 3.88 | 3.88 | 3.88 |
| Boiler max. flow rate ⁴ | GPM | 6.2 | 6.2 | 6.2 |
| | L/h | 1400 | 1400 | 1400 |
| Max. operating pressure (max. allowable working pressure) at 210°F (99°C) | psig | 45 | 45 | 45 |
| | bar | 3 | 3 | 3 |
| Boiler water temperature | | | | |
| - Adjustable high limit (AHL) range - space heating (steady state) | °F (°C) | 86 to 176 (30 to 80) | | |
| - Fixed high limit (FHL) | °F (°C) | 210 (99) | | |
| Boiler connections | | | | |
| Boiler heating supply and return | NPTM (male) | ¾ in. | ¾ in. | ¾ in. |
| Pressure relief valve | NPTF (female) | ¾ in. | ¾ in. | ¾ in. |
| DHW tank heating supply/return | NPTM (male) | ¾ in. | ¾ in. | -- |
| DHW heating | NPTM (male) | -- | -- | ½ in. |
| Drain valve | (male thread) | ¾ in. | ¾ in. | ¾ in. |
| Dimensions | | | | |
| Overall depth | inches | 15¾ | 15¾ | 15¾ |
| | (mm) | (400) | (400) | (400) |
| Overall width | inches | 15¾ | 15¾ | 15¾ |
| | (mm) | (400) | (400) | (400) |
| Overall height | inches | 30¼ | 30¼ | 30¼ |
| | (mm) | (768) | (768) | (768) |

¹ Output based on 140°F (60°C), 120°F (49°C) system supply / return temperature.

² Net AHRI rating based on piping and pick-up allowance of 1.15.

³ If the gas supply pressure exceeds the maximum gas supply pressure value, a separate gas pressure regulator must be installed upstream of the heating system.

⁴ See "System Flow Rates" on pages 25 and 26 in this manual.

Specifications *(continued)*

Standard heating boiler *(continued)*

| | Boiler Model No. | B1HA 26, 94 | B1HA 35, 125 | B1KA 35, 125 |
|--|-------------------------|--------------------|---------------------|---------------------|
| Gas supply connection | NPTM (male) | 3/4 in. | 3/4 in. | 3/4 in. |
| Flue gas ⁵ | | | | |
| Temperature at boiler return temperature of 86°F (30°C) | | | | |
| - at rated full load | °F (°C) | 113 (45) | 113 (45) | 113 (45) |
| - at rated partial load | °F (°C) | 95 (35) | 95 (35) | 95 (35) |
| Temperature at boiler return temperature of 140°F (60°C) | °F (°C) | 167 (75) | 172 (78) | 172 (78) |
| Flue gas value | | | | |
| Mass flow rate (of flue gas) | | | | |
| - at rated full load | lbs/h | 79.2 | 100.1 | 100.1 |
| | kg/h | 36.0 | 45.5 | 45.5 |
| - at rated partial load | lbs/h | 33.0 | 33.0 | 33.0 |
| | kg/h | 15.0 | 15.0 | 15.0 |
| Available draught | Pa | 100 | 100 | 100 |
| | mbar | 1.0 | 1.0 | 1.0 |
| Flue gas temperature sensor limit | °F (°C) | 230 (110) | 230 (110) | 230 (110) |
| Average condensate flow rate ⁶ | | | | |
| with natural gas | | | | |
| - Ts/TR = 122 / 86°F (50 / 30°C) | USG/day | 1.95-2.3 | 2.5-2.8 | 2.5-2.8 |
| | L/day | 8-9 | 9.4-10.5 | 9.4-10.5 |
| Condensate connection ⁷ | hose nozzle Ø in | 1 | 1 | 1 |
| Boiler flue gas connection ⁸ | Ø in (mm) | 2 3/8 (60) | 2 3/8 (60) | 2 3/8 (60) |
| Combustion air supply connection ⁸ | coaxial outer Ø in (mm) | 4 (100) | 4 (100) | 4 (100) |
| | single | 2 3/8 (60) | 2 3/8 (60) | 2 3/8 (60) |
| Noise level (at 1 meter) | | | | |
| - at full load | (dB) | 46.9 | 51.6 | 51.6 |
| - at partial load | (dB) | 41.1 | 41.1 | 41.1 |
| High altitude (factory set) ⁹ | ft. (m) | 0-5,000 (0-1,500) | | |

⁵ Measured flue gas temperature with a combustion air temperature of 68°F (20°C).

⁶ Based on typical boiler cycles, including partial load conditions.

⁷ Requires 1 in. (25 mm) tubing. See Vitodens 100-W Installation Instructions for details.

⁸ For detailed information refer to the Vitodens Venting System Installation Instructions.

⁹ For 5,000 to 10,000 ft. (1,500 to 3,000 m) operation, a control programming change is required. Refer to the Installation and Service Instructions for details.

Note: For altitude operation up to 4,999 feet, derate the input capacity by 3%/1000 ft. (305 m).

For operation from 5,000 to 10,000 ft. (1,500 to 3,000 m), with the electronic altitude adjustment made, derate the input capacity by 3% for every 1000 ft. (305 m) starting at 5000 ft. (1,500 m) for a total of 15%.

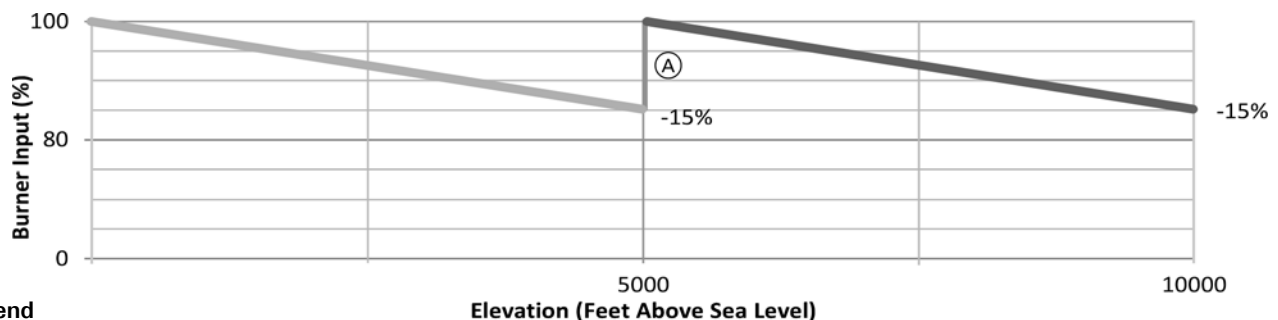

Legend

Ⓐ Input capacity after electronic altitude adjustment is made.

Specifications *(continued)*

B1KA on demand hot water operation

| | Boiler Model No. | B1KA 35, 125 |
|---|-------------------------|---------------------|
| Max. Input NG and LPG (DHW production only) | MBH kW | 149 43.7 |
| Max. boiler temperature (during DHW production) | °F (°C) | 176 (80) |
| DHW supply temperature | °F (°C) | 140 (60) |
| Continuous draw rate *1 at Δ t= 77°F (43K) | USG/min. (L/h) | 3.5 (795) |
| Max. flow through heat exchanger | USG/min. (L/h) | 3.7 (840) |
| Maximum allowable working pressure (potable water) | psi | 150 |
| Test pressure | psi | 300 |
| Integrated pump flow rate DHW production @ 23 ft. (9.8 m) Head pressure | USG/min. (L/h) | 5.63 (1278) |
| Heating system operation with system side additional drop in pressure of max. 6 ft. of water (1.8 m) | USG/min. (L/h) | 6.2 (1408) |
| Expansion tank *2 (for heating system side) Precharge pressure Capacity | psig USG (L) | 12 2.1 (8) |

*1 DCW and DHW temperature rise would be proportional. Maximum DHW supply temperature is 140°F (60°C).

*2 Determine the required size of the expansion tank to be installed in the heating system.
If the integral expansion tank is insufficient, install a suitably sized expansion tank on site.

Boiler Dimensions Without Bottom Piping Connections

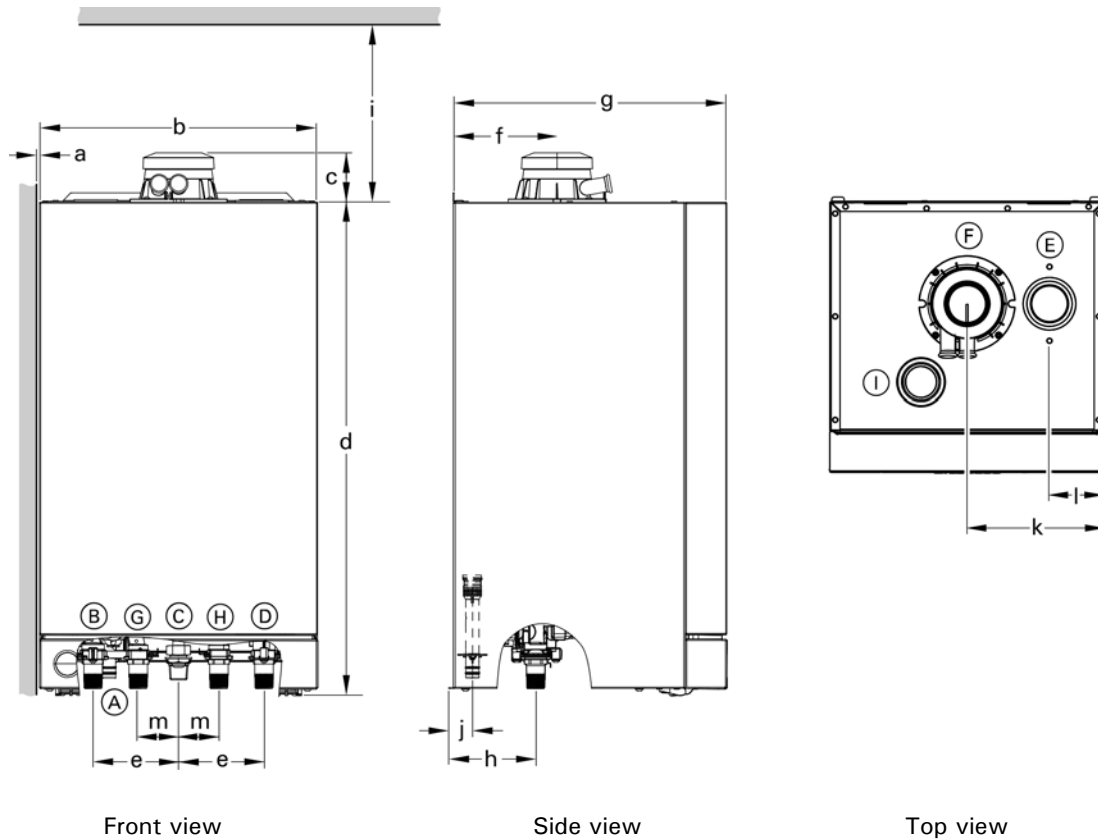

Vitodens 100-W, B1HA series and B1KA combi

Legend

- (A) Condensate drain, plastic hose Ø 1 in. (Ø 22 mm)
- (B) Boiler water supply, NPT ¾ in. (male thread)
- (C) Gas connection, NPT ¾ in. (male thread)
- (D) Boiler water return, NPT ¾ in. (male thread)
- (E) Combustion air opening for double pipe system
- (F) Combustion air opening for coaxial system
- (G) - For B1HA series, DHW tank heating supply
- For B1KA combi, DHW
- (H) - For B1HA series, DHW tank heating return
- For B1KA combi, DCW
- (I) Opening for pressure relief valve

Dimensions

- a* ¼ in. (6 mm) - both sides of the boiler
- b* 15 ¾ in. (400 mm)
- c* 2 ⅝ in. (68 mm)
- d* 27 ½ in. (700 mm)
- e* 4 ⅞ in. (123 mm)
- f* 6 in. (150 mm)
- g* 15 ¾ in. (400 mm)
- h* 5 in. (125 mm)
- i* 9 ⅜ in. (250 mm) minimum
- j* 1 ⅞ in. (34 mm)
- k* 7 ⅞ in. (200 mm)
- l* 3 ½ in. (80 mm)
- m* 2 ¼ in. (58 mm)

Boiler Dimensions With Piping Connections

Piping connections for Vitodens 100-W,
B1HA series and B1KA

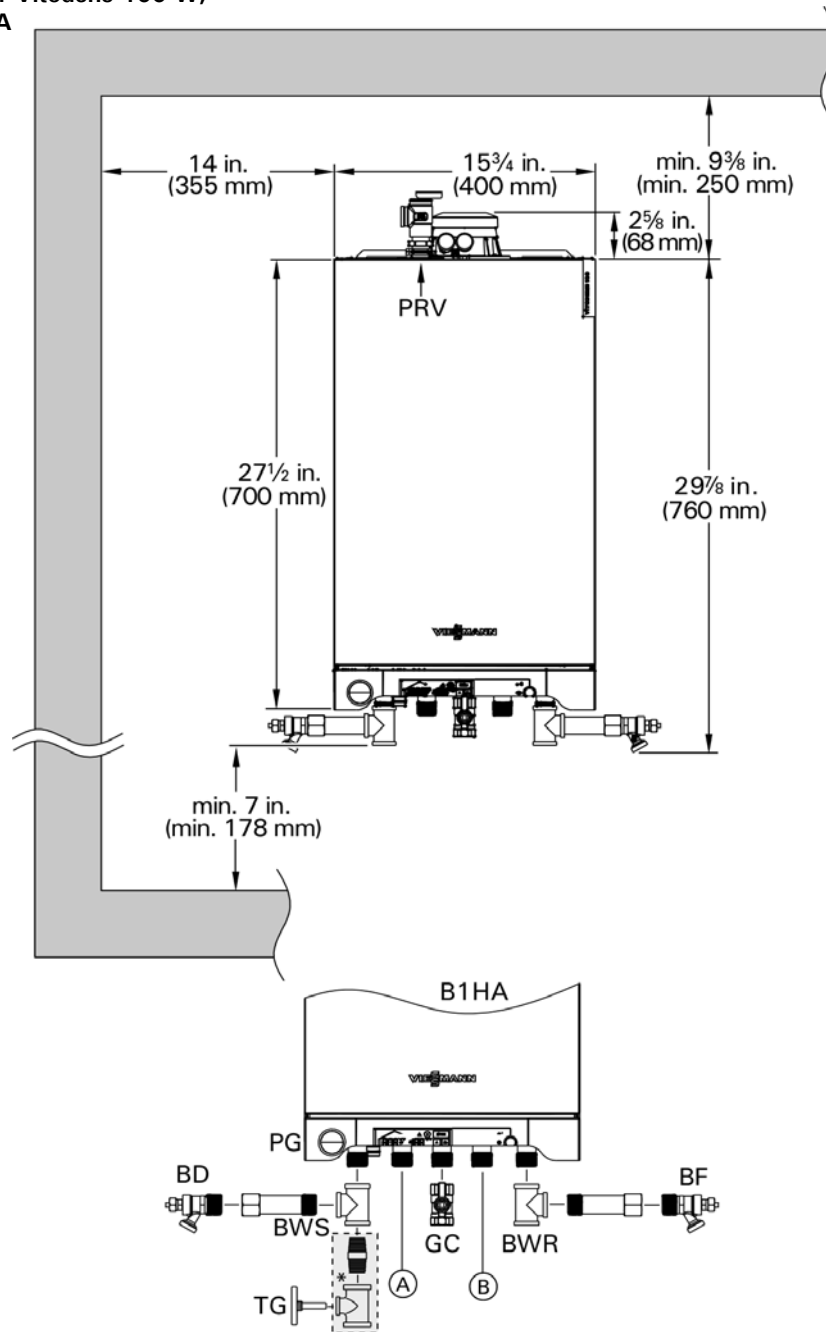

Legend

- Ⓐ - DHW tank heating supply for B1HA boilers
- DHW for B1KA boiler
- Ⓑ - DHW tank heating return for B1HA boilers
- DCW for B1KA boiler

- BWR Boiler water return
- BWS Boiler water supply
- BD Boiler drain
- BF Boiler fill
- GC Gas connection
- PRV Pressure relief valve
- PG Pressure gauge
- VC Venting connection
- TG Temperature gauge
- * Field supplied

Boiler Minimum Clearances

Recommended minimum boiler service clearances

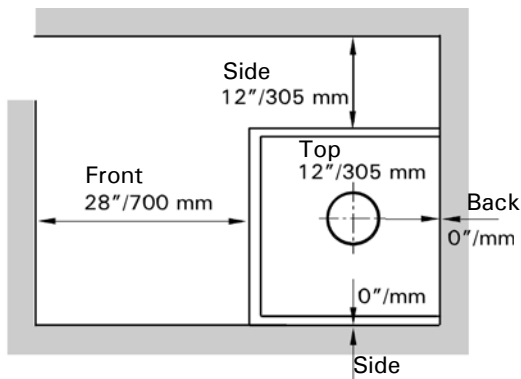

Recommended minimum boiler clearances to combustibles

Note: The Vitodens 100-W boiler has passed the zero inches vent clearance to combustibles testing requirements dictated by the boiler Harmonized Standard ANSI Z21.13. CSA 4.9 (latest edition) and therefore is listed for zero clearance to combustibles when vented with a single-wall special venting system (AL-29-4C material) or UL/ULC-listed CPVC gas vent material. The zero inches vent clearance to combustibles for the Vitodens 100-W boiler supercedes the clearance to combustibles listing that appears on the special venting system label.

Top clearance - 12" (30 cm).



See the Vitodens Venting System Installation Instructions.

Clearance to combustibles

| Top | Front | Rear | Left | Right | Vent pipe *1 |
|-----|----------|------|------|-------|--------------|
| 0 | 0 AL, CL | 0 | 0 | 0 | 0 |

*1 Refer to the Installation Instructions of the Vitodens Venting System for details.

AL = Alcove
CL = Closet

Heating Circuit Pumps

Waterside Flow (boiler circuit)

The Vitodens 100-W is designed only for closed loop, forced circulation hot water heating systems.

Pressure drop (primary circuit) of Vitodens 100-W

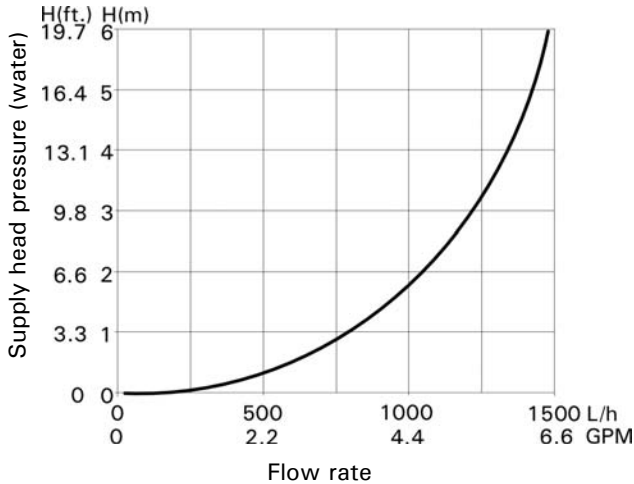

A low-loss header must be used when the system flow rate exceeds the maximum (or minimum) flow rate of the Vitodens 100-W boiler. An alternative method may be used, such as primary secondary piping using closely spaced tees.

A low-loss header offers additional benefits not provided by a pair of closely spaced tees. Viessmann strongly recommends and prefers the use of a low-loss header over closely spaced tees. Please see page 17 for details.

Use standard friction loss method for pipe sizing. Observe boiler maximum and minimum flow rate limitations. If system flow rate exceeds boiler maximum flow rate (as stated on page 17) or if system flow rate is unknown, Viessmann strongly recommends the installation of a low-loss header. See page 17 for low-loss header information or refer to the Vitodens Venting System Installation Instructions.

Heating circuit pumps

The Vitodens 100-W B1HA/B1KA comes with a built-in boiler pump.

All other pumps are field supplied and should be sized based on pressure drop.

IMPORTANT

Pump selection must be based on accurate system flow and pressure drop calculations (including DHW sizing).

Heating Circuit Pumps *(continued)*

Built-in pump - Residual head

Grundfos UPS15-78 three speed heating circuit/DHW production pump for Vitodens 100-W B1HA 26, 35, 94, 125 and B1KA 35, 125 boilers (in the factory setting, the pump speed is preset to 'speed three')

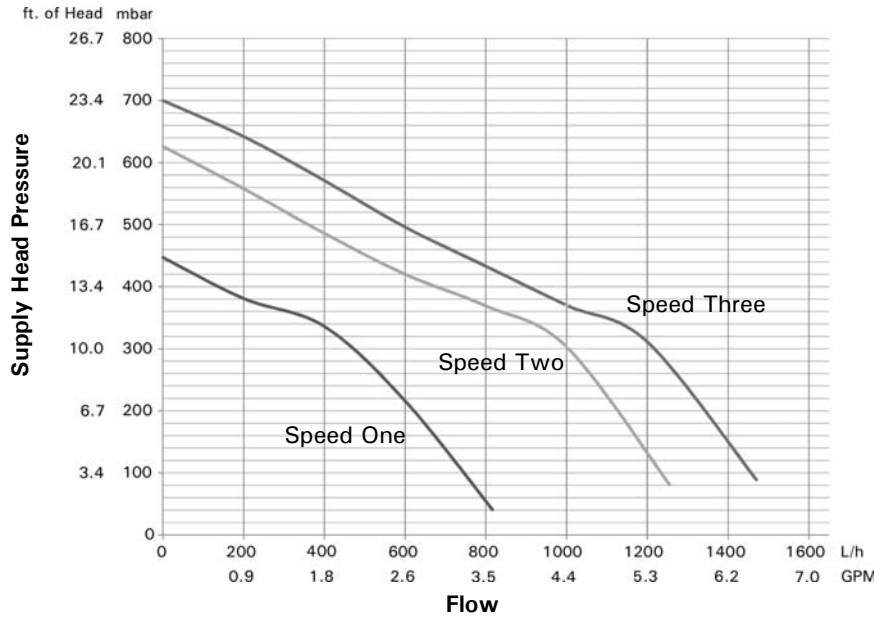

| Pump Model | Grundfos UPS15-78 | |
|-------------------|-------------------|------|
| Rated voltage | VAC | 115 |
| Rated current | A max. | 1.15 |
| | A min. | 0.8 |
| Capacitor | μF | 8 |
| Power consumption | W max. | 130 |
| | W min. | 80 |

Built-in pump, Grundfos UPS15-78 residual head pressure

Residual head of built-in pump at speed 3 (factory set).

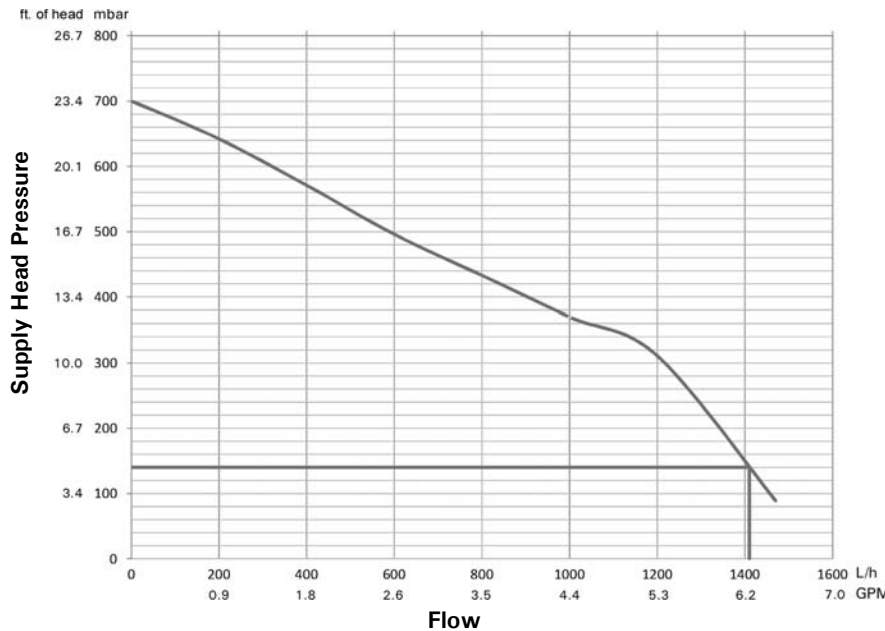

Heating Circuit Pumps *(continued)*

DHW Production Planning

With the B1KA for instantaneous DHW heating or the B1HA DHW connections for DHW production via a stand-alone DHW storage tank, the Vitodens 100-W boilers series offers the right solution for every need.

Various factors must be taken into account when designing the DHW system and when deciding between the instantaneous DHW production with the B1KA and DHW production via a stand-alone DHW storage tank with the B1HA.

Such factors are:

- DHW requirement, level of comfort and convenience
- Number of draw points
- Distance of draw points from the boiler/DHW storage tank
- System retrofit
- Space requirements

Options

| | | B1HA | B1KA |
|--|--|-------------|-------------|
| DHW requirement, level of comfort and convenience | DHW requirement for an apartment | + | + |
| | DHW requirement for a single-family house | + | 0 |
| | Central DHW requirement for a multi-family house | + | - |
| | Decentralized DHW requirement for a multi-family house | + | + |
| Number of draw points | One draw point | 0 | + |
| | Several draw points, non-simultaneous use | 0 | + |
| | Several draw points, simultaneous use | + | - |
| Distance of draw points from the boiler/DHW storage tank | Up to 23 ft. (7 m) (without DHW recirculation line) | - | + |
| | With DHW recirculation line | + | - |
| System retrofit | DHW storage tank already installed | + | - |
| | Replacement of existing Combi boiler | - | + |
| Space requirements | Minimal space available (installation in alcove) | 0 | + |
| | Adequate space available (boiler room) | + | + |

+ (recommended)
 0 (recommended in certain cases)
 - (not recommended)

Heating Circuit Pumps *(continued)*

Domestic Hot Water Production via Instantaneous DHW Plate Heat Exchanger (B1KA)

The B1KA is equipped with an electronically controlled instantaneous DHW plate heat exchanger. The comfort control function (if selected) ensures that the instantaneous DHW plate heat exchanger is kept warm. This translates into immediate availability of domestic hot water at any required temperature level.

Technical Data DHW Plate Heat Exchanger

See pages 4,5 and 6 in this manual for technical data.

B1KA heat exchanger performance

DHW supply temperature for B1KA 35, 125 (with mixed water)

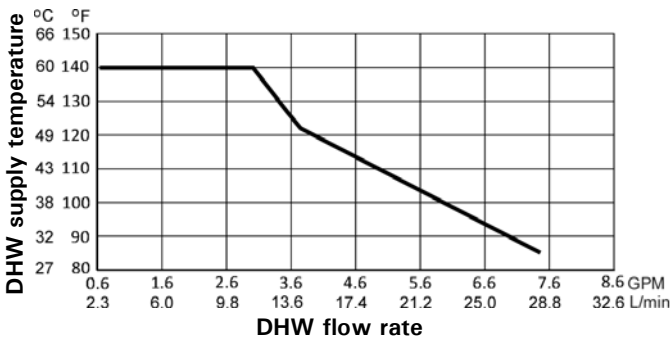

This chart illustrates the changes in the outlet temperature, subject to the flow rate at the tap.

If greater volume (max. flow rate through heat exchanger = 3.7 GPM) of water is required, cold water needs to be mixed which reduces the outlet temperature.

Curve is only applicable for a DCW inlet temperature of 50°F and a boiler input of 149,000 MBH (Vitodens 100-W, B1KA 35, 125).

Max. recovery rate @ DHW temperature of 140°F = 3.0 GPM
Min. flow through the heat exchanger for boiler start = 0.4 GPM

IMPORTANT

A diaphragm expansion tank is integrated into the Vitodens 100 B1KA, with a capacity of 2.1 USG (8 L) and a pre-charge pressure of 12 psig.

Determine the required size of the expansion tank to be installed in the heating system. If the integral expansion tank is insufficient, install a suitably sized expansion tank on site.

BiKA - 35 DHW Pressure Drop

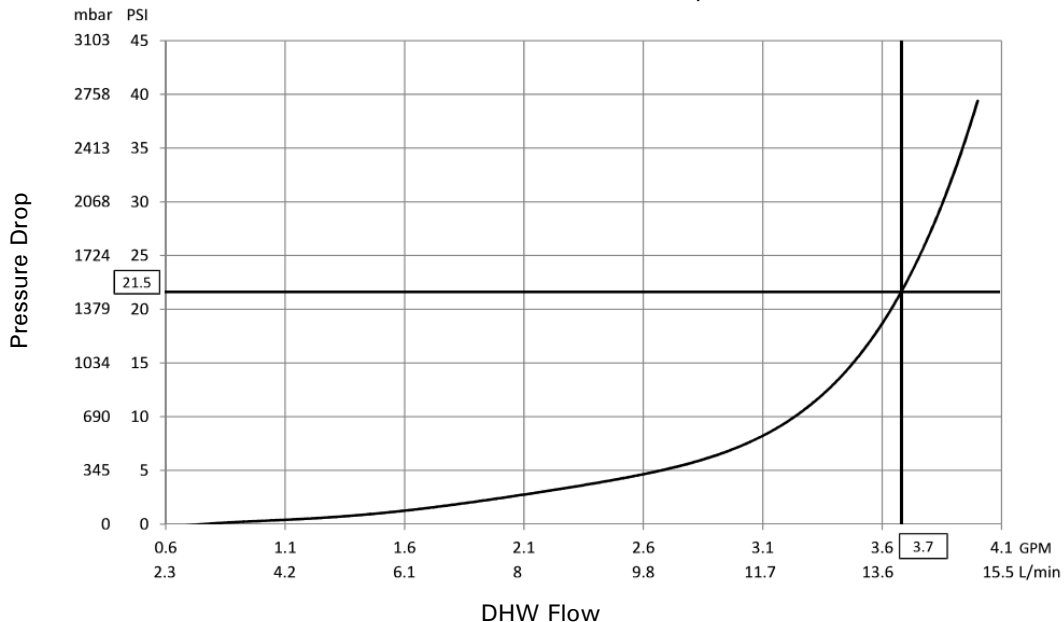

Mounting

Mounting Vitodens 100-W boiler

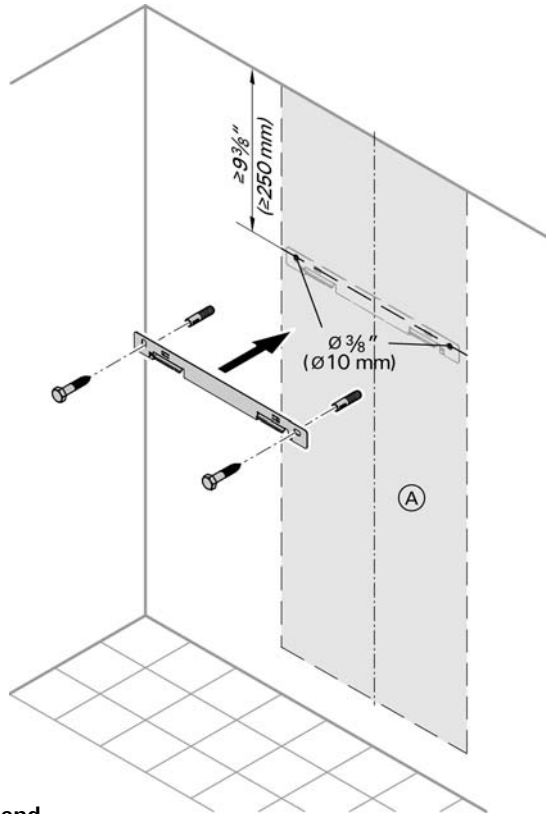

Legend

(A) Boiler mounting

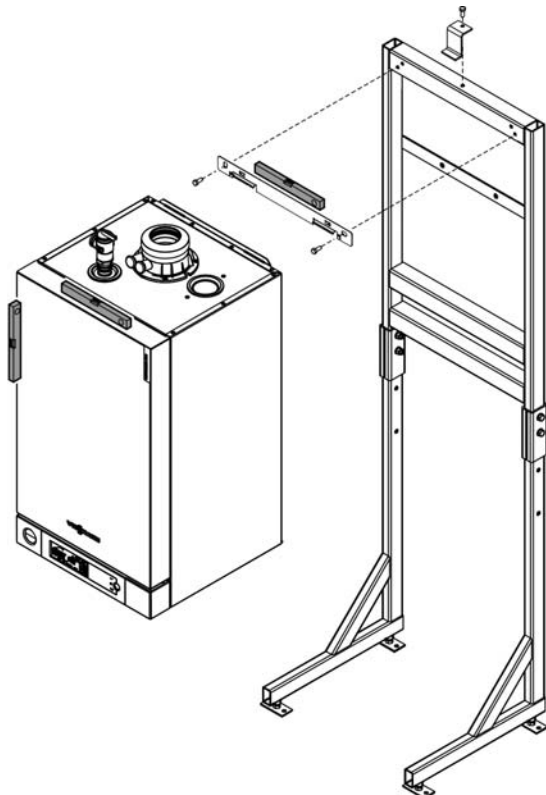

Domestic Hot Water Production via DHW Storage Tank

Vitodens 100-W B1HA series boilers can be used in conjunction with the stand-alone DHW storage tanks offered by Viessmann.

Size and select the DHW storage tank based on the forecast DHW consumption of the building in question.

For further technical information on DHW storage tanks, see the Vitocell Technical Data Manual.

Boiler mounting bracket and frame

1. Attach the wall mounting bracket (supplied with the boiler) to the boiler mounting frame using the supplied hardware. Ensure that the wall mounting bracket is level.
2. Move the rack into position and secure to the floor (and to the wall if needed).

CAUTION

The boiler must be level both vertically and horizontally to ensure proper draining of the condensate.



Refer to the single boiler rack Installation Instructions for more details.

Condensate

Condensate Connection

Install the condensate drain pipe \varnothing 7/8 in. (\varnothing 22 mm) with a suitable gradient (min. 2.5%).

Discharge condensate from the boiler into the drainage system, either directly or (if required) via a neutralization unit (accessory).

Condensate connection for Vitodens 100-W

- model B1HA 26, 35, 94, 125 and B1KA 35, 125

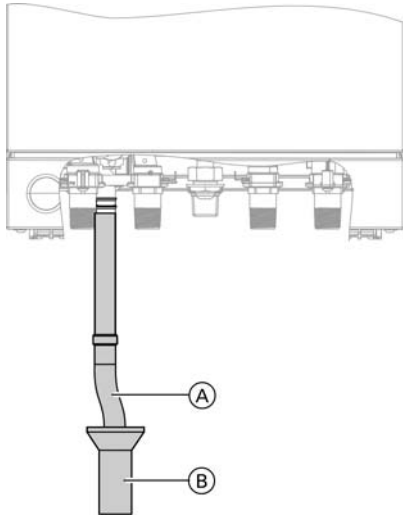

Legend

- (A) Flexible discharge tubing
- (B) Discharge tubing

The condensate drain of the Vitodens 100-W boiler is equipped with a built-in siphon trap in order to keep flue gases from being discharged via the condensate drain.

IMPORTANT

Pipe ventilation must take place between the siphon trap and the neutralization unit (if applicable).

Condensate Drainage and Condensate Neutralization

The condensate formed both in the condensing boiler and in the flue gas pipe must be discharged into the public sewage system in accordance with all applicable local regulations. The condensate produced by a gas-fired heating system has a pH value between 3 and 4.

Some local codes may require the use of a separate neutralization unit to treat the aggressive and corrosive condensate.

With a neutralization unit installed, all condensate from the boiler and the flue gas pipe enters into the neutralization unit where it is treated and released into the public sewage system with a safe pH value of above 6.5.

The use of neutralization granulate (performing the neutralizing process) is dependent on the operation of the heating system. To determine the required refill amount, check granulate level several times during the first year of operation. In some cases one granulate fill may last an entire year.

Contact Viessmann to order a neutralization unit for the Vitodens 100-W boiler.

See Viessmann Price List for order information.

The condensate discharge outlet to the drainage system connection must be clearly visible. It must be installed with a suitable gradient and provided with a stench trap.

If the condensate outlet of the Vitodens 100-W boiler is lower than the drain, a condensate pump must be used.

Only corrosion-resistant materials may be used for condensate drainage purposes (e.g. braided hose). Do not use galvanized materials or materials containing copper for piping, couplings etc. The condensate drain must have a trap.

Please note that other requirements may apply depending on local regulations and/or project-specific details.

It is advisable to contact your local waterworks office (authority responsible for waste water regulations) well before commencing with the installation of the neutralization unit in order to establish details of local regulations that apply.

The following table shows the concentration of (effluent) substances (e.g. heavy metals) contained in the waste water from the Vitodens 100-W condensing boiler.

| Condensate (effluent) substances | Values measured in mg/L Vitodens 100 |
|----------------------------------|--------------------------------------|
| Lead | < 0.01 |
| Cadmium | < 0.005 |
| Chromium | < 0.01 |
| Copper | < 0.01 |
| Nickel | < 0.01 |
| Zinc | < 0.05 |
| Tin | < 0.05 |

Venting Options / Electrical Connections

Vitodens 100-W Venting Options

For detailed information refer to the Vitodens Venting System Installation Instructions.

Electrical Connection

All electrical connections are made to the boiler's integrated boiler control unit (120VAC, 1 phase, 60 Hz, 12 amps).

Use disconnect means and power service switch as per local code requirements.

Control Unit

Function and construction:

The control is integrated into the Vitodens 100-W boiler.

- Integrated diagnostic system
- For room temperature-dependent operation, an external control or a room temperature thermostat may be connected
- To control DHW temperature
- External heat demand
- OpenTherm (OT) or OT input module 0-10VDC (accessory)
- Viessmann outdoor temperature sensor (OTS) (field wiring)
- OpenTherm (OT) (field wiring)
- Instantaneous DHW control (B1KA)

The control unit consists of:

- LCD Display
- Push button operation and setting of boiler water temperature
- Temperature adjustable high limit
- Boiler temperature sensor
- Burner fault display
- Burner fault reset
- Pressure gauge
- Fuse

Boiler temperature sensor

The boiler temperature sensor is connected to the control unit and built into the boiler.

Frost protection

Frost protection is continuously active. The burner is switched ON when the boiler water temperature reaches 41°F (5°C) and is switched OFF again when the boiler water temperature reaches at least 59°F (15°C) [but not more than 68°F (20°C)].



For details on the control, refer to the Vitodens 100-W Operating Instructions.

Accessories

Accessories for the Vitodens 100-W

Neutralization Unit for Single-Boiler Applications with neutralizing granulate for Vitodens 100-W, B1HA 26, 35, 94, 125 and B1KA 35, 125
Part No. 7134 231

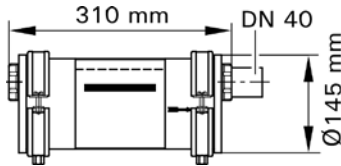

Low-Loss Header

- Type 80/60 [max. flow rate 19.5 GPM (4.4 m3/h)]
- Type 120/80 [max. flow rate 35.2 GPM (8 m3/h)]

A low-loss header offers additional benefits not provided by a pair of closely spaced tees. Viessmann strongly recommends and prefers the use of a low-loss header over closely spaced tees. When used in conjunction with the Vitodens 100-W boiler, the low-loss header acts as hydraulic break, decoupling boiler and system circuits from each other (no sensor required). It is recommended to use the low-loss header in applications in which the total system flow rate exceeds the maximum or falls below the minimum flow rate of the Vitodens 100-W boiler.

For maximum boiler flow rates, see the table on pages 10 and 11 in this manual.

Viessmann strongly recommends the use of a low-loss header in cases where the system head and flow rates are unknown.

In addition, the low-loss header helps eliminate air and debris [D] from the heating system. See illustrations for Low-loss header design and the principle of operation. Product may not look exactly as illustrated.

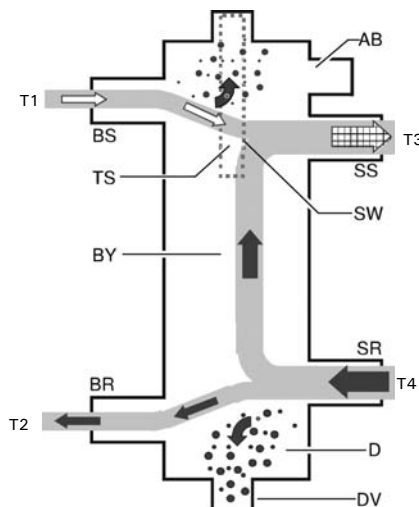

Low-loss header design

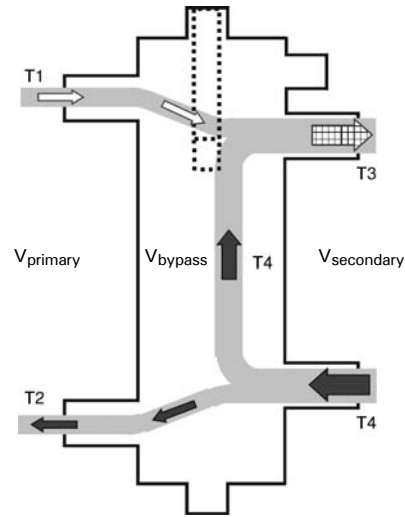

Principal of operation

The low-loss header is available in the following sizes. Select the size based on the maximum system flow rate of your application.

| Model No. | Max. system flow rate |
|-------------|-----------------------|
| Type 80/60 | 19.5 GPM (4.4 m3/h) |
| Type 120/80 | 35.2 GPM (8 m3/h) |

Legend

| | | | |
|----|----------------------------|----|-----------------------------------|
| AB | Air Bleed | DV | Drain Valve |
| BR | Boiler Return | SR | System Return |
| BS | Boiler Supply | SS | System Supply |
| BY | Bypass (with laminar flow) | TS | Viessmann Temp. Sensor (not used) |
| D | Debris and/or air | SW | Sensor Well |
| T1 | Boiler supply temp. | T3 | System supply temp. |
| T2 | Boiler return temp. | T4 | System return temp. |

- $V_{primary}$ Boiler circuit flow rate
- $V_{secondary}$ Heating circuit flow rate
- V_{bypass} Bypass flow rate
- $Q_{primary}$ Heat supplied by boiler
- $Q_{secondary}$ Heat consumed by system

$V_{primary} < V_{secondary}$
 $T1 > T3$
 $T2 = T4$
 $Q_{primary} = Q_{secondary}$

$T1 \ 176^{\circ}F (80^{\circ}C)$
 $V_{secondary} = V_{primary} + V_{bypass}$

IMPORTANT

When installing a low-loss header, system mixed supply temperature (T3) must be calculated as follows

$$T3 = \frac{T1 \times V_{primary} + T4 \times V_{bypass}}{V_{secondary}}$$

Product may not look exactly as illustrated.

Accessories

Outdoor Temperature Sensor (OTS)

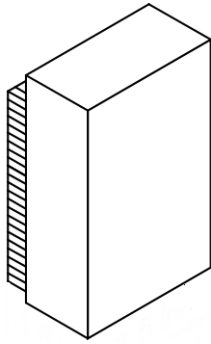

Sensor location:

- North or northwest wall of building
- 80 to 100 in. (2 to 2.5 m) above ground or in case of a multi-storey building approximately halfway up the second floor

Electrical connection:

- 2-wire cable, max. cable length 115 ft. (35 m) with a wire size of min. AWG 16 copper
- Cable to the outdoor sensor must not be laid near line voltage wiring (120/240V)

Max. ambient temperature during transport, storage and operation:

-40 to 194°F (-40 to 90°C)

Viessmann NTC 10 kΩ

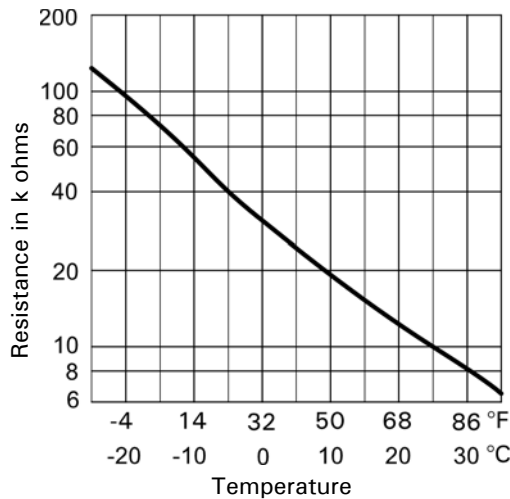

DHW Tank Temperature Sensor
(immersion temperature sensor)

Supplied with:

- Cable length approx. 13 ft. (3.75 m), ready to plug in
- All pipe connections are field supplied.

Specification

Max. ambient temp.

- at operation: 32 to 194°F (0 to 90°C)
- when storing or transporting: - 4 to + 158°F (-20 to + 70°C)
- Sensor type: Viessmann NTC
10K ohms @ 77°F (25°C)

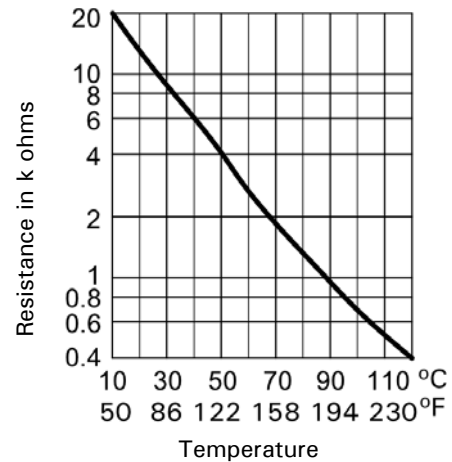

Standard Equipment

Standard Equipment

The Vitodens 100-W gas-fired condensing boiler with Inox-Radial heat exchanger surfaces, modulating stainless steel MatriX cylinder gas burner c/w:

- installation fittings with 30 psig pressure relief valve, air vent and pressure gauge
- two fill/drain valves
- all mounting hardware
- Outdoor temperature sensor (OTS)
- temperature gauge
- DHW pressure relief valve (B1KA)
- DHW sensor (B1HA)

The boiler comes fully piped and pre-wired.

Wall mounting componentry

The following wall mounting components are supplied with the Vitodens 100-W boiler:

- Mounting bracket
- Mounting bolts
- Installation fittings
- Screws for mounting bracket on
 - wood studs (2 in. x 4 in.)
 - metal studs
 - brick/concrete wall

How the Vitodens 100-W boiler operates...

The Vitodens 100-W boiler uses a premix combustion system, which is designed to deliver a certain air-gas mixture to the burner for complete combustion. The gas is injected upstream of the blower. The burner and heat exchanger are part of a forced-draft design. The benefits of forced-draft systems are lower component temperatures, direct air-fuel connection (premix) for improved mixing, and longer service life of the boiler due to mild to moderate ambient conditions.

The MatriX cylinder burner, blower and the combination gas valve are factory calibrated and pre-adjusted. A pneumatic link between combustion air and gas flows guarantees optimal boiler performance at all firing rates. Blower speed is automatically increased or decreased based on heat demand, thereby regulating the amount of combustion air drawn. The pneumatic link between air and gas introduces the required amount of gas for optimal combustion to meet the current heat demand, based on a linear relationship between ΔP air and ΔP gas.

Installation Examples

IMPORTANT

The examples on the following pages depict possible piping layouts of the Vitodens 100-W boiler.

Please note that the following examples are simplified conceptual drawings only!

Piping and necessary componentry must be field verified. A low water cut-off (LWCO) must be installed where required by local codes. Proper installation and functionality in the field is the responsibility of the heating contractor.

System Layout 1

Vitodens 100-W, B1HA 26, 35, 94, 125 with one heating circuit

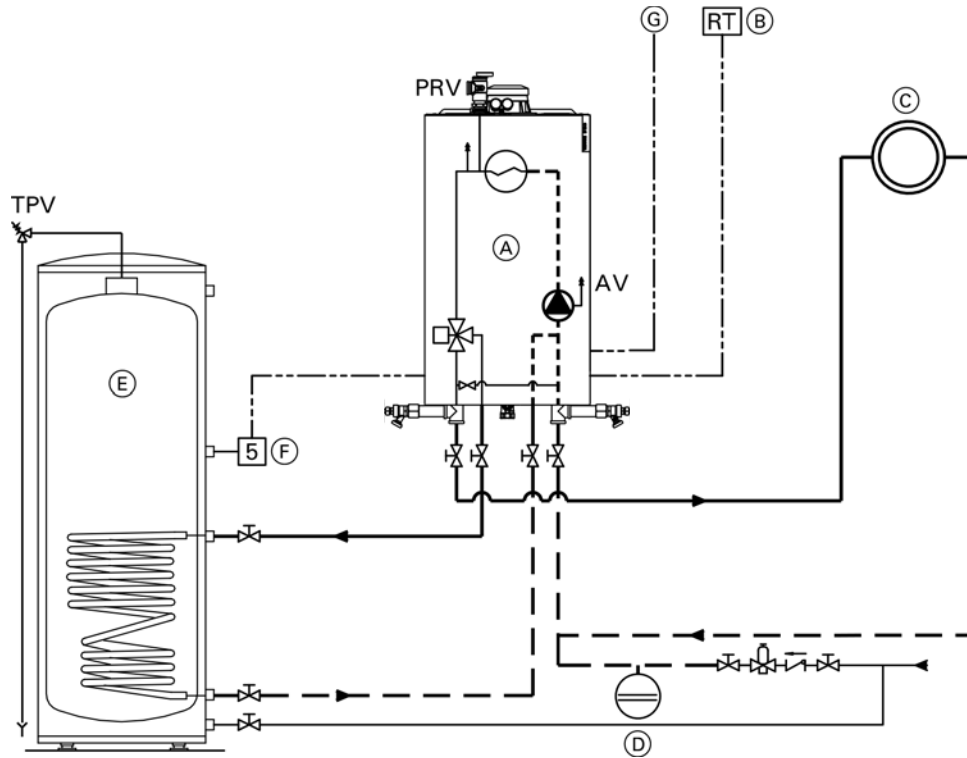

Legend

- AV Air vent
- PRV Pressure relief valve
- TPV Temperature and pressure relief valve
- (A) Vitodens 100-W
- (B) Room thermostat
- (C) Heating circuit
- (D) Expansion tank
- (E) DHW storage tank
- (F) DHW tank temperature sensor
- (G) Outdoor temperature sensor (OTS)

Note: The use of a low-loss header is recommended if the water flow rate is less than 1.7 GPM (400 L/h) or more than 6.2 GPM (1400 L/h).
The low-loss header is available as accessory part.

IMPORTANT

Ensure that a pressure activated by-pass is installed if there are system component(s) in (C) that may isolate the flow to the pump.

Maximum Flow Rates

| Model B1HA | | 26, 94 | 35, 125 |
|--------------------|-----------|------------|-------------|
| Output | MBH | 88 | 117 |
| Δt | | | |
| 30°F (17°C) rise | GPM (L/h) | 5.9 (1332) | 7.8 (1772)* |
| 35°F (19.5°C) rise | GPM (L/h) | 5.0 (1142) | 6.7 (1522)* |
| 40°F (22°C) rise | GPM (L/h) | 4.4 (999) | 5.9 (1328) |

* Requires low loss header or closely spaced tees.

System Layout 2

Vitodens 100-W, B1HA 26, 35, 94, 125 with...

- DHW storage tank
- low-loss header
- one heating circuit

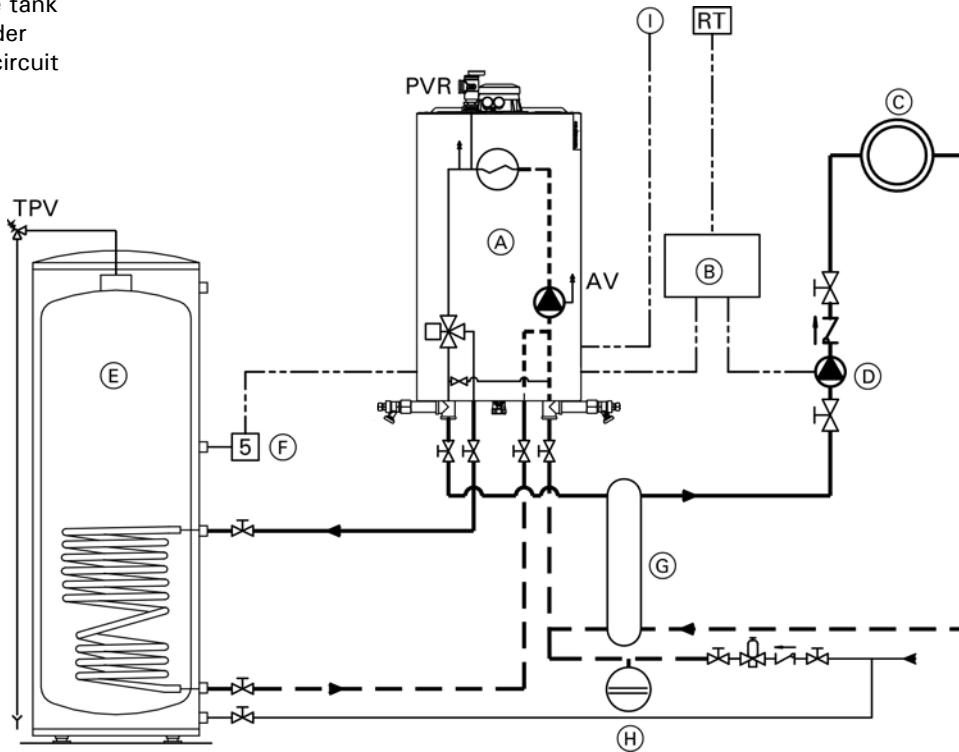

Legend

- AV Air vent
- PRV Pressure relief valve
- TPV Temperature and pressure relief valve
- (A) Vitodens 100-W gas-fired condensing boiler
- (B) External boiler controller with room thermostat connection (field supplied)
- (C) Heating circuit
- (D) Heating circuit pump (field supplied)
- (E) DHW storage tank
- (F) DHW tank temperature sensor
- (G) Low-loss header (there is no LLH temperature sensor available for the B1HA)
- (H) Expansion tank
- (I) Outdoor temperature sensor (OTS)

Note: The use of a low-loss header is recommended if the water flow rate is less than 1.7 GPM (400 L/h) or more than 6.2 GPM (1400 L/h). The low-loss header is available as accessory part.

IMPORTANT

DHW supply and return piping between boiler DHW connections and the Viessmann DHW tank connections, shall be a minimum of 1 in. nominal pipe diameter (irrespective of the 3/4 in. DHW connection outlet sizes provided on the boiler and the DHW tank).

This ensures that the head of the pump is fully utilized to overcome the resistance of the DHW heat exchanger coil and to provide sufficient water flow to the boiler heat exchanger.

In non-Viessmann DHW tank applications, perform, in addition to the above, accurate calculations for DHW tank coil pressure drop versus boiler pump head to ensure sufficient water flow to the boiler heat exchanger.

Failure to heed the above instructions may cause boiler short-cycling and inadequate DHW supply.

Maximum Flow Rates

| Model B1HA | | 26, 94 | 35, 125 |
|--------------------|-----------|------------|-------------|
| Output | MBH | 88 | 117 |
| Δt | | | |
| 30°F (17°C) rise | GPM (L/h) | 5.9 (1332) | 7.8 (1772)* |
| 35°F (19.5°C) rise | GPM (L/h) | 5.0 (1142) | 6.7 (1522)* |
| 40°F (22°C) rise | GPM (L/h) | 4.4 (999) | 5.9 (1328) |

* Requires low loss header or closely spaced tees.

System Layout 3

Vitodens 100-W, B1HA 26, 35, 94, 125 with DHW storage tank and one heating circuit

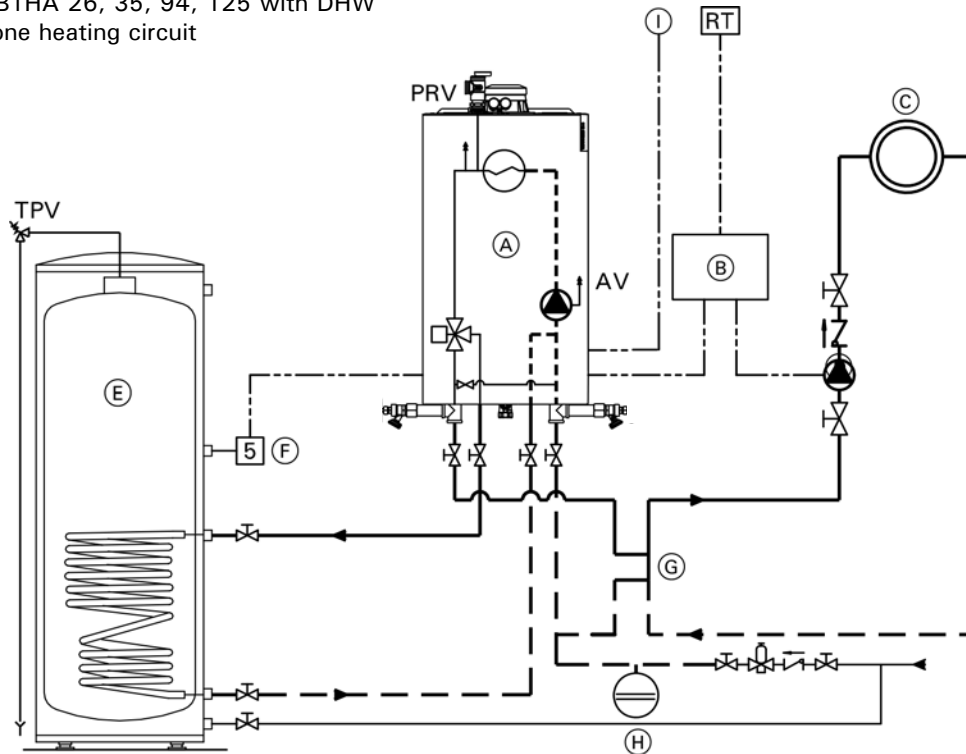

Legend

- AV Air vent
- PRV Pressure relief valve
- TPV Temperature and pressure relief valve
- (A) Vitodens 100-W gas-fired condensing boiler
- (B) External boiler controller (field supplied)
- (C) Heating circuit
- (D) Heating circuit pump with room thermostat connection (field supplied)
- (E) DHW storage tank
- (F) DHW tank temperature sensor
- (G) Closely spaced tees, 4x pipe Ø or 12 in. (305 mm)*
- (H) Expansion tank
- (I) Outdoor temperature sensor (OTS)

* A low-loss header offers additional benefits not provided by a pair of closely spaced tees. Viessmann strongly recommends and prefers the use of a low-loss header over closely spaced tees. See page 17 for details.

Maximum Flow Rates

| Model B1HA | | 26, 94 | 35, 125 |
|--------------------|-----------|------------|-------------|
| Output | MBH | 88 | 117 |
| Δ t | | | |
| 30°F (17°C) rise | GPM (L/h) | 5.9 (1332) | 7.8 (1772)* |
| 35°F (19.5°C) rise | GPM (L/h) | 5.0 (1142) | 6.7 (1522)* |
| 40°F (22°C) rise | GPM (L/h) | 4.4 (999) | 5.9 (1328) |

* Requires low loss header or closely spaced tees.

Note: The use of a low-loss header is recommended if the water flow rate is less than 1.7 GPM (400 L/h) or more than 6.2 GPM (1400 L/h). The low-loss header is available as an accessory part.

IMPORTANT

DHW supply and return piping between boiler DHW connections and the Viessmann DHW tank connections, shall be a minimum of 1 in. nominal pipe diameter (irrespective of the ¾ in. DHW connection outlet sizes provided on the boiler and the DHW tank).

This ensures that the head of the pump is fully utilized to overcome the resistance of the DHW heat exchanger coil and to provide sufficient water flow to the boiler heat exchanger.

In non-Viessmann DHW tank applications, perform, in addition to the above, accurate calculations for DHW tank coil pressure drop versus boiler pump head to ensure sufficient water flow to the boiler heat exchanger.

Failure to heed the above instructions may cause boiler short-cycling and inadequate DHW supply.

System Layout 4

Vitodens 100-W, B1KA 35, 125 with one heating circuit

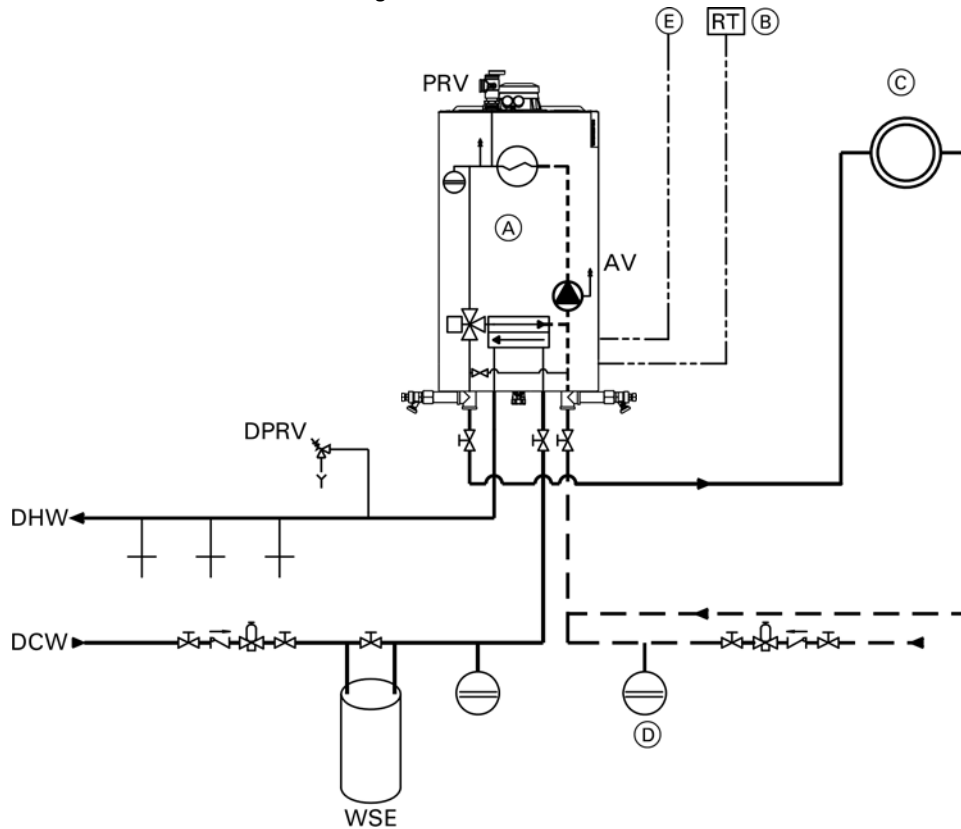

Legend

- AV Air vent
- PRV Pressure relief valve (boiler)
- DPRV Pressure relief valve (DHW 150 psi)
- WSE Water softener equipment
- DHW Domestic hot water
- DCW Domestic cold water
- (A) Vitodens 100-W
- (B) Room thermostat
- (C) Heating circuit
- (D) Expansion tank
- (E) Outdoor temperature sensor (OTS)

Note: The use of a low-loss header is recommended if the water flow rate is less than 1.7 GPM (400 L/h) or more than 6.2 GPM (1400 L/h). The low-loss header is available as accessory part.

Built-in pump residual head for the heating system side is 4.3 ft. of water column at the boiler maximum flow rate of 6.2 GPM.

Maximum Flow Rates

| Model B1KA | | 35, 125 |
|--------------------|-----------|-------------|
| Output | MBH | 117 |
| Δt | | |
| 30°F (17°C) rise | GPM (L/h) | 7.8 (1772)* |
| 35°F (19.5°C) rise | GPM (L/h) | 6.7 (1522)* |
| 40°F (22°C) rise | GPM (L/h) | 5.9 (1328) |

* Requires low loss header or closely spaced tees.

System Layout 5

Vitodens 100-W, B1KA 35, 125 with...

- low-loss header
- one heating circuit

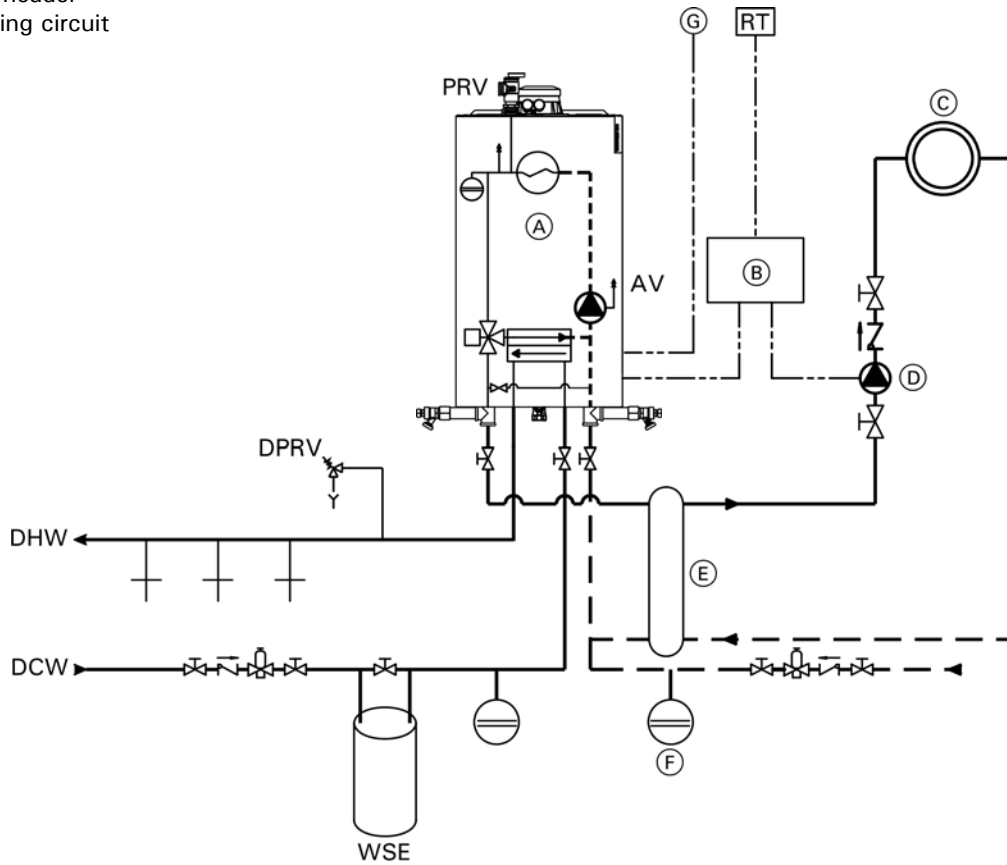

Legend

- AV Air vent
- PRV Pressure relief valve (boiler)
- DPRV Pressure relief valve (DHW 150 psi)
- WSE Water softener equipment
- DHW Domestic hot water
- DCW Domestic cold water
- (A) Vitodens 100-W gas-fired condensing boiler
- (B) External boiler / system controller with room thermostat connection (field supplied)
- (C) Heating circuit
- (D) Heating circuit pump (field supplied)
- (E) Low-loss header (there is no LLH temperature sensor available for the B1KA)
- (F) Expansion tank
- (G) Outdoor temperature sensor (OTS)

Note: The use of a low-loss header is recommended if the water flow rate is less than 1.7 GPM (400 L/h) or more than 6.2 GPM (1400 L/h).
The low-loss header is available as accessory part.

Maximum Flow Rates

| Model B1KA | | 35, 125 |
|--------------------|-----------|-------------|
| Output | MBH | 117 |
| Δt | | |
| 30°F (17°C) rise | GPM (L/h) | 7.8 (1772)* |
| 35°F (19.5°C) rise | GPM (L/h) | 6.7 (1522)* |
| 40°F (22°C) rise | GPM (L/h) | 5.9 (1328) |

* Requires low loss header or closely spaced tees.

System Layout 6

Vitodens 100-W, B1KA 35, 125 with one heating circuit without LLH

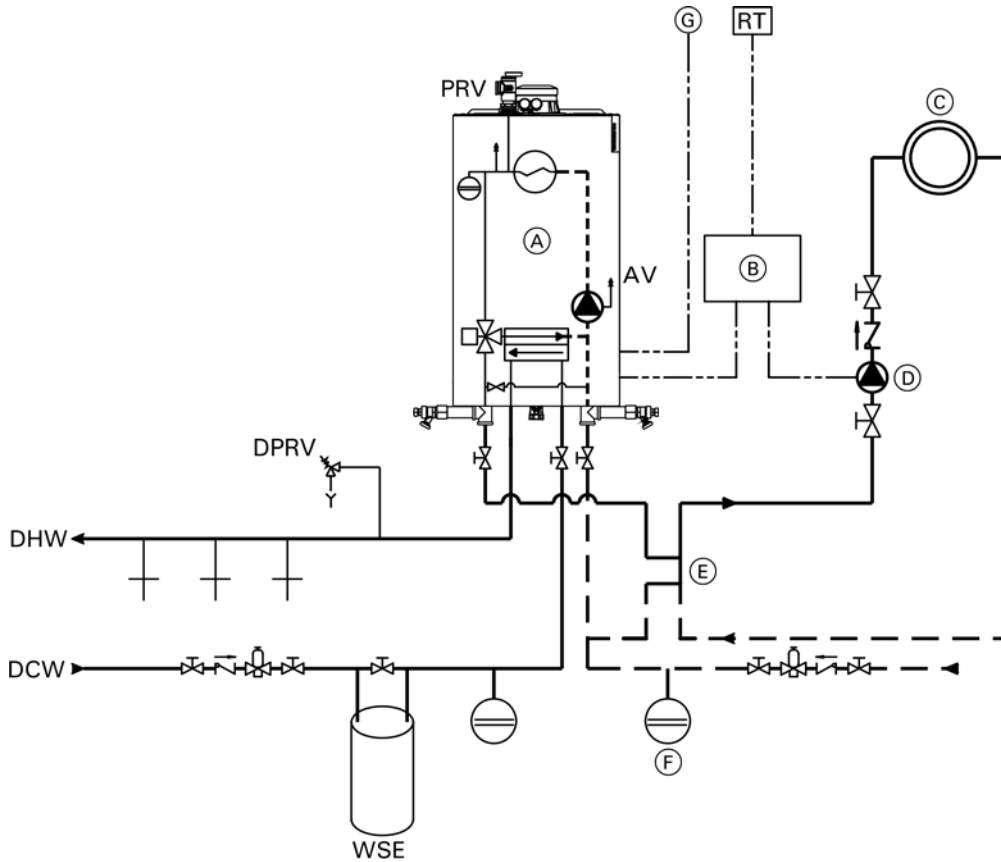

Legend

- AV Air vent
- PRV Pressure relief valve (boiler)
- DPRV Pressure relief valve (DHW 150 psi)
- WSE Water softener equipment
- DHW Domestic hot water
- DCW Domestic cold water
- (A) Vitodens 100-W gas-fired condensing boiler
- (B) External system controller (field supplied)
- (C) Heating circuit
- (D) Heating circuit pump with room thermostat connection (field supplied)
- (E) Closely spaced tees, 4x pipe Ø or 12 in. (305 mm) * 1
- (F) Expansion tank
- (G) Outdoor temperature sensor (OTS)

* 1 A low-loss header offers additional benefits not provided by a pair of closely spaced tees. Viessmann strongly recommends and prefers the use of a low-loss header over closely spaced tees. See page 17 for details.

Note: The use of a low-loss header is recommended if the water flow rate is less than 1.7 GPM (400 L/h) or more than 6.2 GPM (1400 L/h). The low-loss header is available as an accessory part.

Maximum Flow Rates

| Model B1KA | | 35, 125 |
|--------------------|-----------|--------------|
| Output | MBH | 117 |
| Δt | | |
| 30°F (17°C) rise | GPM (L/h) | 7.8 (1772) * |
| 35°F (19.5°C) rise | GPM (L/h) | 6.7 (1522) * |
| 40°F (22°C) rise | GPM (L/h) | 5.9 (1328) |

* Requires low loss header or closely spaced tees.

System Design Considerations

IN THE COMMONWEALTH OF MASSACHUSETTS...

- this product shall be installed by a licensed plumber or gas fitter.
- the flexible connector (if used) may not exceed 36".
- any level type shutoff used must be of tee handle type.

Boiler location

As a direct vent appliance, the Vitodens 100-W may be installed for room air independent operation (sealed combustion direct vent) regardless of size and ventilation method of the room in which it is located.

The Vitodens 100-W may be installed, for example, in the main living area of a house, in non-ventilated utility rooms, cupboards, closets and alcoves with no clearance required from combustible materials, as well as in attics with a direct outlet for the flue gas/fresh air system. Follow all local and national codes.

Flue gas system

Viessmann coaxial PPS (Polypropylene - flame retardant) concentric flue gas/fresh air systems and two-pipe stainless steel/CPVC systems for room air independent operation (sealed combustion) and side wall venting are tested to ANSI Z21.13 - CSA 4.9 standards (latest edition) and are certified together with the Vitodens 100-W boiler as a constructional unit. The Vitodens 100-W boiler may also be vented vertically or horizontally, using a metallic AL29-4C® special stainless steel, or non-metallic CPVC single-wall, room air dependent venting system (UL/ULC listed for category IV).

For a more detailed description of the direct vent and single-wall vent system, please refer to the Vitodens Venting System Installation Instructions.

Flue gas temperature protection

Viessmann coaxial PPS (Polypropylene - flame retardant) flue pipes used for the Vitodens 100-W are rated for max. flue gas temperatures of up to 230°F (110°C).

Flue gas temperature protection is also included although the maximum permissible flue gas temperature will not be exceeded in any operating condition or in the event of malfunctioning.

Low water cut-off

A low water cut-off may be required by local codes. If the boiler is installed above the radiation level, a low water cut-off device of approved type must be installed in all instances. An approved low water cut-off device that meets government and local regulations must be provided by the heating contractor.

Do not install an isolation valve between the boiler and the low water cut-off. The Vitodens 100-W boiler has a built-in flow switch, which may be accepted by local codes in lieu of a low water cut-off.

System layout

- The max. boiler water temperature for ...
 - space heating is 176°F (80°C).
 - DHW production is 176°F (80°C).

To minimize distribution losses, Viessmann recommends that the heating and domestic hot water systems be based on a maximum boiler supply temperature of 158°F (70°C).

- Due to the low return temperatures required for gas condensing, avoid the use of mixing valves in the heating circuit whenever possible. If mixing valves are required, e.g. for multi-circuit systems or underfloor heating systems, only 3-way mixing valves may be used. Do not use 4-way mixing valves in a system with condensing boilers.

Water connections

Vitodens 100-W boilers can be used in any fully pumped hot water heating system.

Minimum system pressure is 12 psig (0.8 bar).

Chemical corrosion protection products

Corrosion does not typically occur in sealed heating systems which have been correctly installed and are correctly operated.

Many manufacturers of plastic pipes recommend the use of chemical additives. In this case, only commercially available corrosion protection products that have been approved for boilers with domestic hot water heating via single-wall heat exchangers (instantaneous plate heat exchangers or DHW tanks) may be used.

Underfloor heating systems

For underfloor heating systems Viessmann recommends the use of plastic tubing with an oxygen diffusion barrier in order to prevent the diffusion of oxygen through tubing. If plastic tubing without an oxygen diffusion barrier is used in underfloor heating systems, Viessmann recommends that such systems be separated from the boiler with a heat exchanger.

Water Conditions for DHW B1KA 35, 125

Media: pH value 6.5 to 12, glycol max. 30%

DHW (max. hardness): Chloride up to 250 mg/L

Hardness up to 358 ppm
(= max. 0.278 kg/m³ lime deposit)

System Design Considerations *(continued)*

Oxygen diffusion barrier underfloor tubing

The boiler warranty does not cover leaks resulting from corrosion caused by the use of underfloor plastic tubing without an oxygen diffusion barrier. Such systems must have the non-oxygen diffusion barrier tubing separated from the boiler with a heat exchanger.

Viessmann recommends the use of underfloor plastic tubing with an oxygen diffusion barrier.

Water quality

Treatment for boiler feed water should be considered in areas of known problems, such as where a high mineral content and hardness exist. In areas where freezing might occur, an antifreeze may be added to the system water to protect the system. Please adhere to the specifications given by the antifreeze manufacturer.

Do not use automotive silicate based antifreeze. Please observe that an antifreeze/water mixture may require a backflow preventer within the automatic water feed and influence components such as diaphragm expansion tanks, radiation, etc. Maximum antifreeze content is 50% for the B1HA 26, 35, 94, 125 and 30% for the B1KA 35, 125. Do not use antifreeze other than specifically made for hot water heating systems.

The system may also contain components which might be negatively affected by antifreeze.

Check total system frequently when filled with antifreeze. Advise system operator/ultimate owner that system is filled with a glycol mix.

The heating contractor must provide a MSDS (Material Safety Data Sheet) for the antifreeze used to the system operator/ultimate owner.

Warranty

Our warranty does not cover damages resulting from the following:

- installation or service by unqualified and unlicensed personnel.
- attempting to perform any repair work on the boiler other than that mentioned in the boiler literature.
- tampering with or attempting to readjust the factory settings of the combination gas valve
- leaks resulting from corrosion caused by the use of underfloor plastic tubing without an oxygen diffusion barrier.

For detailed warranty information, please read warranty sheet supplied with product.

| Total output (MBH) | Total Hardness (ppm as CaCO ₃) |
|--------------------|--|
| > 1 Total ≤ 680 | ≤ 200 |
| > 680 to ≤ 2050 | ≤ 150 |
| > 2050 | ≤ 2 |

The pH value of the heating water should be between 8.2 and 9.5

Coaxial System

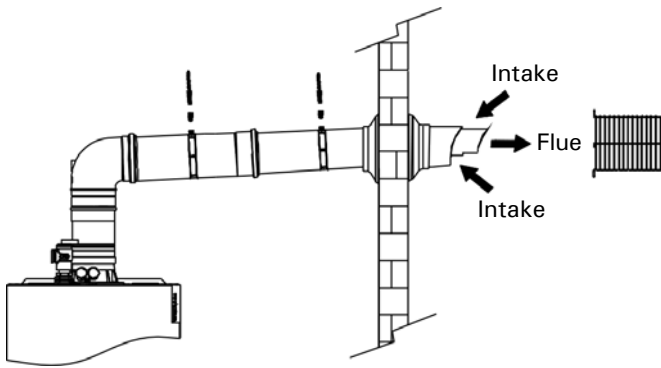

Coaxial, horizontally vented, PP(s) (Viessmann supplied)

| | | | |
|-----------------------------------|---------|---------|----------|
| Vent system diameter (mm) | 60/100 | 80/125 | 100/150 |
| Maximum equivalent length ft. (m) | 82 (25) | 98 (30) | 118 (36) |

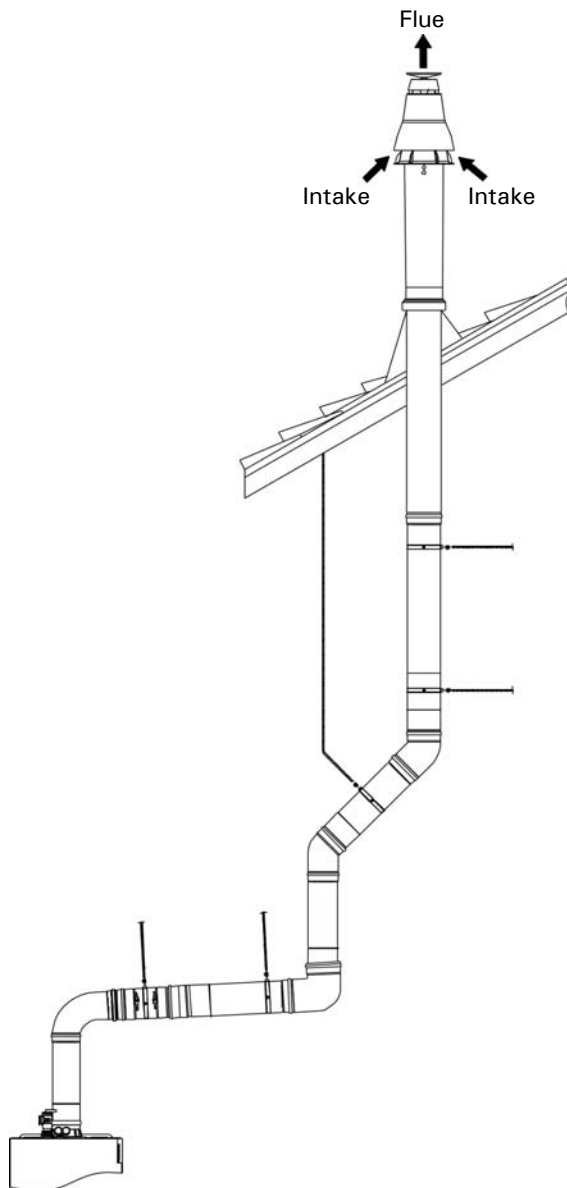

Coaxial, vertically vented, PP(s) (Viessmann supplied)

| | | | |
|-----------------------------------|---------|---------|----------|
| Vent system diameter (mm) | 60/100 | 80/125 | 100/150 |
| Maximum equivalent length ft. (m) | 82 (25) | 98 (30) | 118 (36) |

Two Pipe System

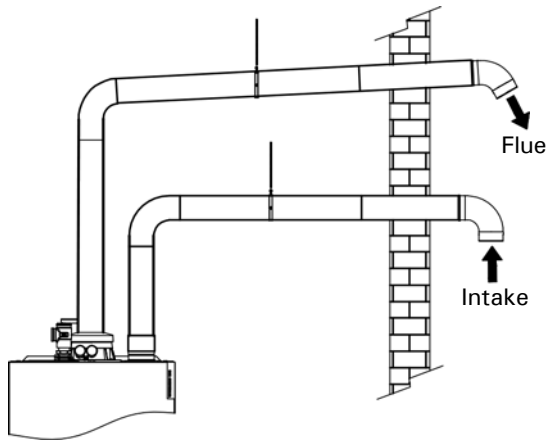

Two pipe system (room air independent) horizontally vented

| | | | |
|-----------------------------------|---------|----------|----------|
| Vent system diameter (in) | 2* | 3 | 4 |
| Maximum equivalent length ft. (m) | 98 (30) | 164 (50) | 200 (61) |

*stainless steel is not available in 2 in.
 Combustion air: CPVC, PVC, ABS and stainless steel (field supplied)
 Flue gas: CPVC and stainless steel (field supplied)
 PP(s): (Viessmann supplied)

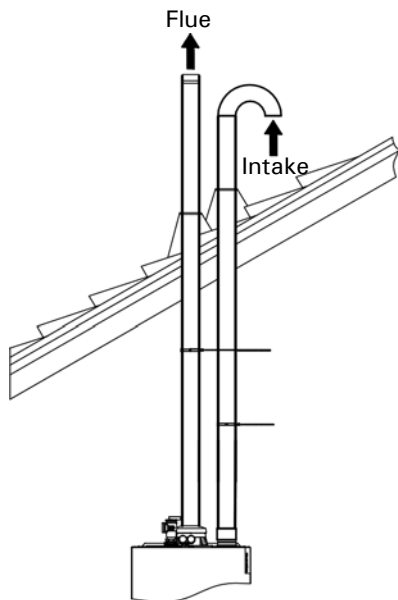

Two pipe system (room air independent) vertically vented

| | | | |
|-----------------------------------|---------|----------|----------|
| Vent system diameter (in) | 2* | 3 | 4 |
| Maximum equivalent length ft. (m) | 98 (30) | 164 (50) | 200 (61) |

*stainless steel is not available in 2 in.
 Combustion air: CPVC, PVC, ABS and stainless steel (field supplied)
 Flue gas: CPVC and stainless steel (field supplied)
 PP(s): (Viessmann supplied)

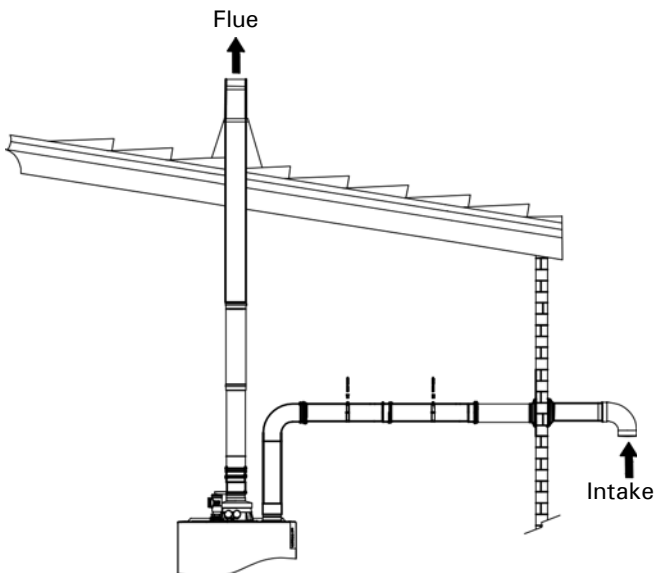

Two pipe system (room air independent) hybrid

| | | | |
|-----------------------------------|---------|----------|----------|
| Vent system diameter (in) | 2* | 3 | 4 |
| Maximum equivalent length ft. (m) | 98 (30) | 164 (50) | 200 (61) |

*stainless steel is not available in 2 in.
 Combustion air: CPVC, PVC, ABS and stainless steel (field supplied)
 Flue gas: CPVC and stainless steel (field supplied)
 PP(s): (Viessmann supplied)

Single Pipe System

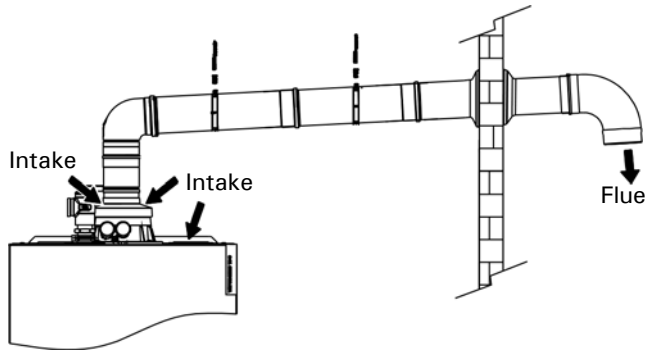

Single pipe system (room air dependant) horizontally vented

| | | | |
|-----------------------------------|---------|----------|----------|
| Vent system diameter (in) | 2* | 3 | 4 |
| Maximum equivalent length ft. (m) | 86 (20) | 164 (50) | 200 (61) |

*stainless steel is not available in 2 in.

CPVC and stainless steel (field supplied)
PP(s) (Viessmann supplied)

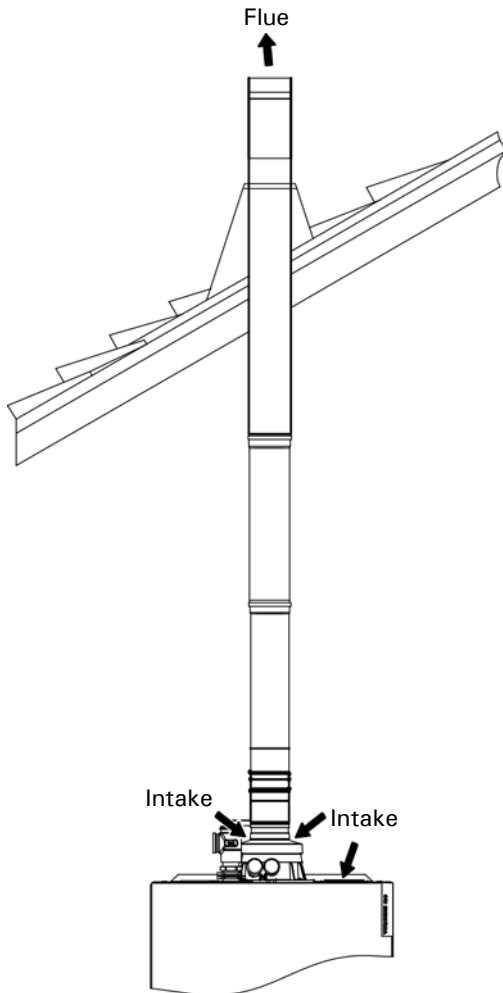

Single pipe system (room air dependant) vertically vented

| | | | |
|-----------------------------------|---------|----------|----------|
| Vent system diameter (in) | 2* | 3 | 4 |
| Maximum equivalent length ft. (m) | 86 (20) | 164 (50) | 200 (61) |

*stainless steel is not available in 2 in.

CPVC and stainless steel (field supplied)
PP(s) (Viessmann supplied)

Flexible System

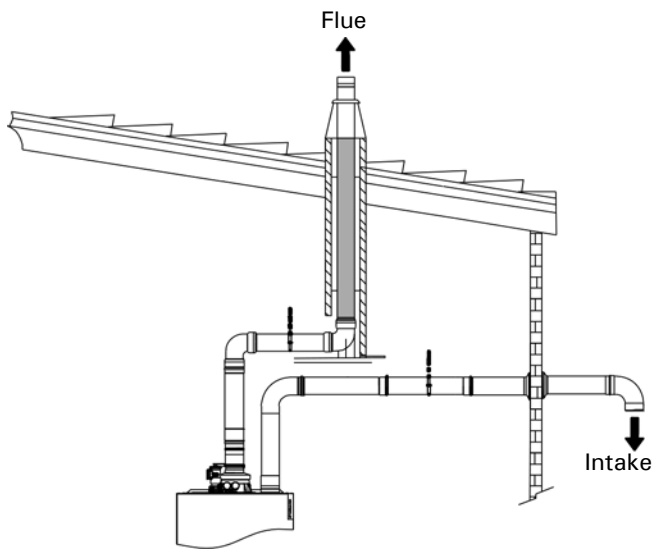

Flexible two pipe system (room air independent)

| | | | |
|-----------------------------------|------------------------|----------|----------|
| Vent system diameter (in) | 80 flex 2 in. comb. | 80 | 100 |
| Maximum equivalent length ft. (m) | 65 (20) | 123 (37) | 150 (46) |

Combustion air: CPVC, PVC, ABS and stainless steel
(field supplied)

Flue gas: PP(s) (Viessmann supplied)

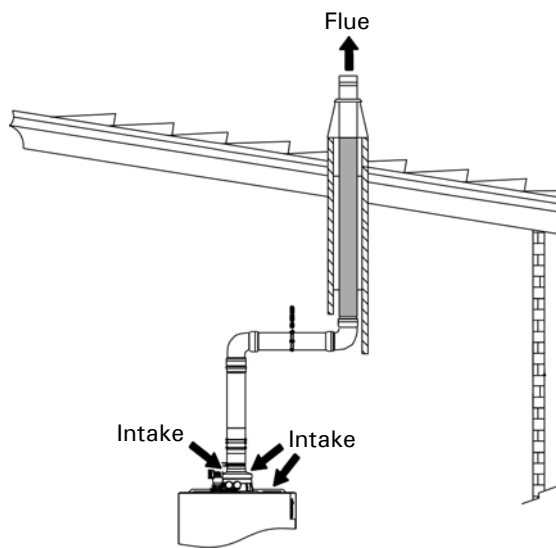

Flexible single pipe system (room air dependant)

| | | |
|-----------------------------------|----------|----------|
| Vent system diameter (in) | 80 | 100 |
| Maximum equivalent length ft. (m) | 123 (37) | 150 (46) |

PP(s) (Viessmann supplied)

Quick Reference

| °C | °F |
|------|------|
| -40 | -40 |
| -35 | -31 |
| -25 | -13 |
| -20 | -4 |
| -18 | 0 |
| -16 | +3 |
| -14 | +7 |
| -12 | +10 |
| -10 | +14 |
| -9 | +16 |
| -8 | +18 |
| -7 | +19 |
| -6 | +21 |
| -5 | +23 |
| -4 | +25 |
| -3 | +27 |
| -2 | +28 |
| -1 | +30 |
| 0 | +32 |
| +1 | +34 |
| +2 | +36 |
| +3 | +37 |
| +4 | +39 |
| +5 | +41 |
| +6 | +43 |
| +7 | +45 |
| +8 | +46 |
| +9 | +48 |
| +10 | +50 |
| +12 | +54 |
| +14 | +57 |
| +16 | +61 |
| +18 | +64 |
| +20 | +68 |
| +25 | +77 |
| +30 | +86 |
| +35 | +95 |
| +40 | +104 |
| +50 | +122 |
| +60 | +140 |
| +70 | +158 |
| +80 | +176 |
| +90 | +194 |
| +100 | +212 |
| +110 | +230 |

Printed on environmentally friendly
(recycled and recyclable) paper.



Technical information subject to change without notice.

Scan for
digital copy
of this
document



Viessmann Manufacturing Company Inc.
750 McMurray Road
Waterloo, Ontario • N2V 2G5 • Canada
TechInfo Line 1-888-484-8643
1-800-387-7373 • Fax (519) 885-0887
www.viessmann.ca • info@viessmann.ca

Viessmann Manufacturing Company (U.S.) Inc.
45 Access Road
Warwick, Rhode Island • 02886 • USA
TechInfo Line 1-888-484-8643
1-800-288-0667 • Fax (401) 732-0590
www.viessmann-us.com • info@viessmann-us.com